

Titan Articulating Arm Dual Plasma Media Cart

Mobile Dual Display Media Cart

The Titan Articulating Arm Dual Plasma Cart with its unique articulating display mounting system allows the displays to be folded up for easy transportation. When the displays are folded, the cart and displays fit in a standard elevator, fit through standard doors and then unfold for use.

ClearOne[®]



MEDIA CART

APPLICATIONS

- + Video Conferencing
- + Distance Learning
- + Education
- + Courtroom
- + Telemedicine

BENEFITS

- + First Truly Mobile Dual Plasma Media Cart
- + Unique Articulating Display Mounting System:
 - > "Folds up" for transportation
 - > Fits in standard elevators
 - > Fits through standard doorways
 - > "Unfolds" for Conference Operation
- + Fits (2) standard 42" - 50" Plasma or LCD displays
 - > Universal Mounting System
 - > Arms Support up to 200 lbs
- + Designed for Strength and Reliability
 - > Steel construction
 - > Cart supports up to 800 lbs of equipment (Total weight)
- + Easy installation and integration of equipment
 - > Minimal job site assembly
 - > Front and Back panel access
 - > Grommet feeds from equipment access
 - > Camera shelf
 - > Equipment shelf

FEATURES

- + Integrated camera mounting shelf
 - > Adjustable camera shelf
 - > Fits new HD cameras
- + 9 space rack system
 - > 22" depth
 - > 2" rack rails
 - > Back panel access
- + Equipment shelf
 - > 7 1/2"
 - > Removable vented front panel
- + Casters
 - > 5 1/2" casters
 - > Rated for 220 lbs each



> Specifications

Titan Articulating Arm Dual Plasma

Media Cart Includes:

- Universal Base Cart
- Articulating Arm Assembly
- Two universal display mounts
- Integrated camera shelf
- Associated assembly hardware

Integrated 19" Rack

- Height: 9 Spaces - 15.75"
- Depth: 22" Video/Telephone Dialing
- Rack Rails: Included
- Rail Recess: 2" Clearance from front door

Casters

- Type:
 - > Two Swivel with Brake
 - > Two Fixed
- Weight Rating: 220 lbs each

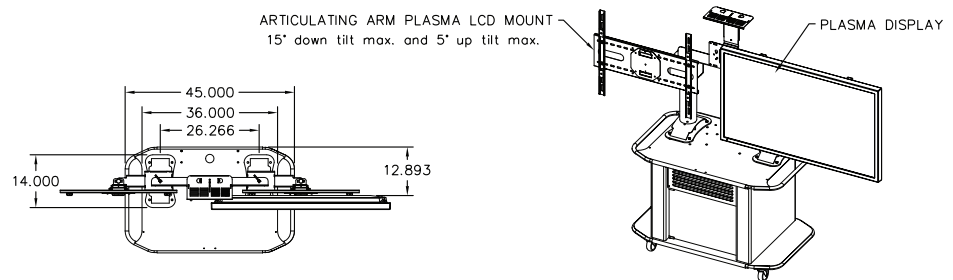

Vented Back Panel

- Height: 17"
- Width: 17"
- Attachment: Four #8 - 32 screws

Part Number

911-300-025

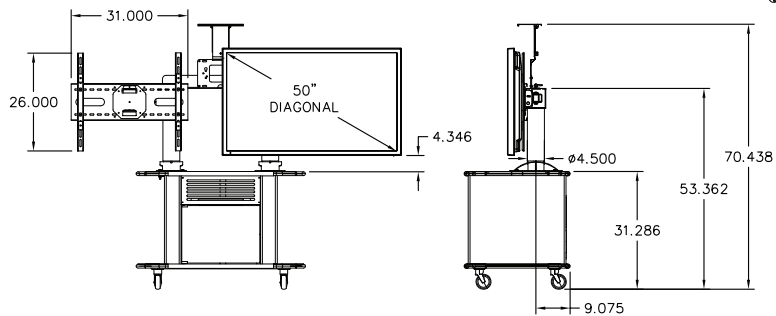

Measurements are in inches

> CLEARONE LOCATIONS

Headquarters:
Salt Lake City, UT USA
 5225 Wiley Post Way
 Suite 500
 Salt Lake City, UT 84116
Tel: 801-975-7200
Toll Free: 800-945-7730
Fax: 801-977-0087
sales@clearone.com

Latin America
Tel: 801-974-3621
global@clearone.com

EMEA
Tel: 44 (0) 1189 036 053
global@clearone.com

APAC
Tel: 801-303-3388
global@clearone.com