



Installation and Assembly: Universal Tilt Brackets for LCD and Plasma Flat Panel Screens 42" - 71" (107 - 180 cm)

Models: ACC-DSV503, ACC-DSV503-P

Features:

- Universal tilt brackets easily hook onto wall plate for fast installation
- Adjustable up to 15° of forward tilt and up to -5° backward tilt for optimal viewing angle
- One-touch tilt for effortless adjustment
- Pre-tensioned universal tilt bracket allows for tilt angle adjustment in one easy motion.
- Easy grip handle locks the screen position into place
- Optional IncreLok feature offers fixed tilts at -5°, 0°, 5°, 10° and 15° increments
- Includes Sorted-For-You™ fastener pack for installation to wood studs, concrete, and cinder block

Accessories:

- DS-ACC-LDCM cable management accessory (optional)
- DS-VL-H024 24" wall plate (optional)
- DS-VL-H036 36" wall plate (optional)
- DS-VL-H048 48" wall plate (optional)
- DS-VL-H060 60" wall plate (optional)
- DS-VL-H072 72" wall plate (optional)

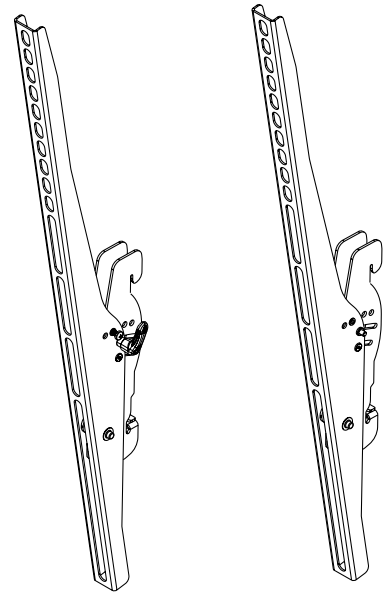

Maximum Load Capacity: 250 lb (113 kg)

▲ WARNING

- Do not begin to install your Peerless product until you have read and understood the instructions and warnings contained in this Installation Sheet. If you have any questions regarding any of the instructions or warnings, for US customers please call Peerless customer care at 1-800-865-2112, for all international customers, please contact your local distributor.
- This product should only be installed by someone of good mechanical aptitude, has experience with basic building construction, and fully understands these instructions.
- Make sure that the supporting surface will safely support the combined load of the equipment and all attached hardware and components.
- Never exceed the Maximum Load Capacity. See page one.
- Always use an assistant or mechanical lifting equipment to safely lift and position equipment.
- Tighten screws firmly, but do not overtighten. Overtightening can damage the items, greatly reducing their holding power.
- This product is intended for indoor use only. Use of this product outdoors could lead to product failure and personal injury.

NOTE: Read entire instruction sheet before you start installation and assembly.

Before you begin, be sure all parts shown are included with your product.

| Parts List | | ACC-DSV503 | | ACC-DSV503-P | |
|------------------------------|-------------|--------------------|--------------------|---------------------|--------------------|
| Description | Qty. | Part Number | Part Number | Part Number | Part Number |
| AA left tilt bracket | 1 | 201-1474 | 201-1473 | 201-1473 | |
| BB right tilt bracket | 1 | 201-1476 | 201-1475 | 201-1475 | |
| CC 4 mm allen wrench | 1 | 560-1131 | | N/A | |

Parts may appear slightly different than illustrated.

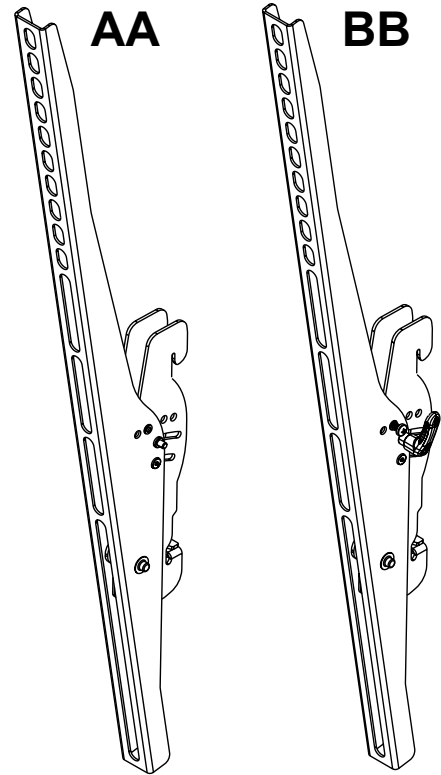
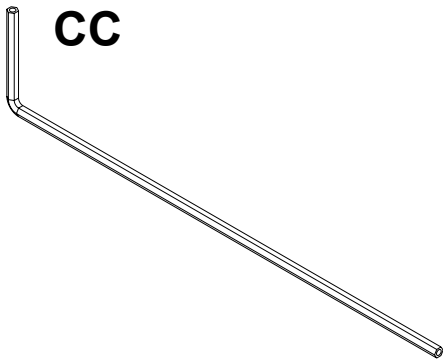

Non-Security Tilt Bracket Fasteners

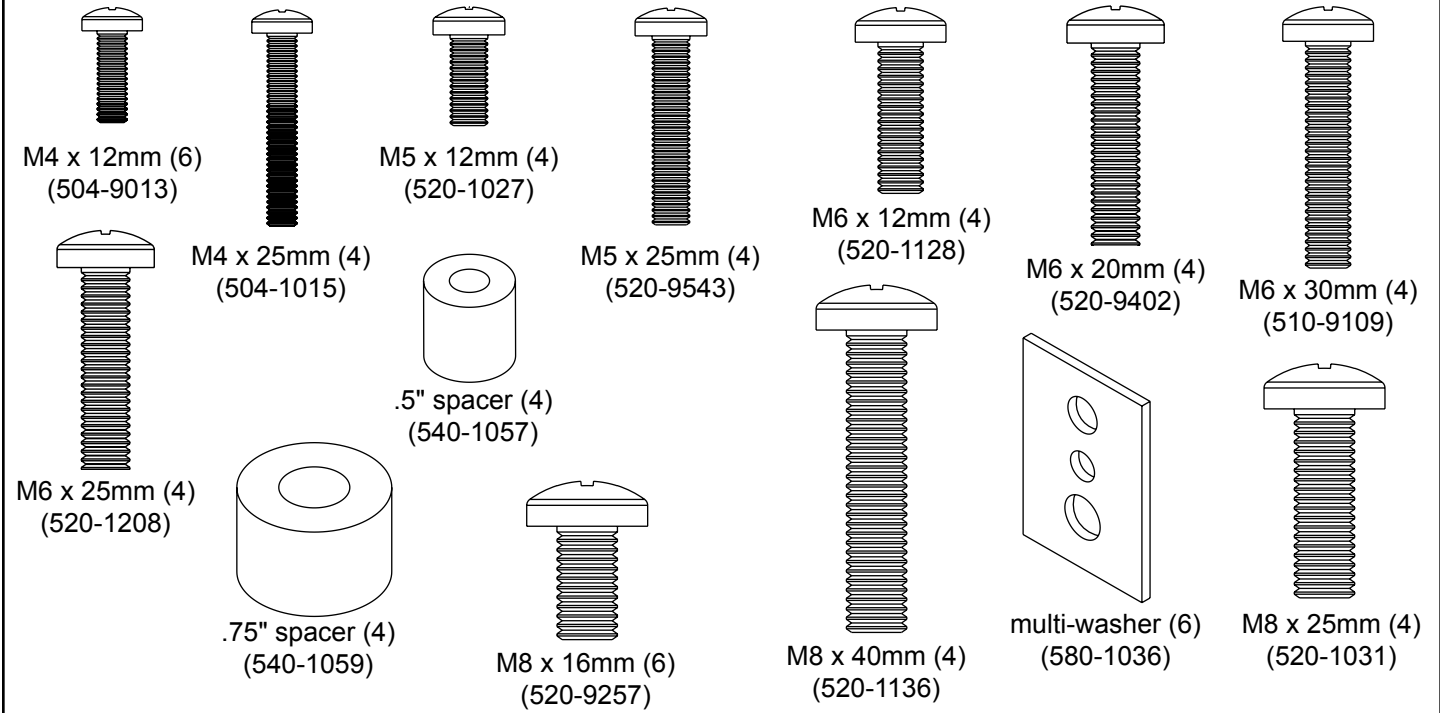

Security Tilt Bracket Fasteners

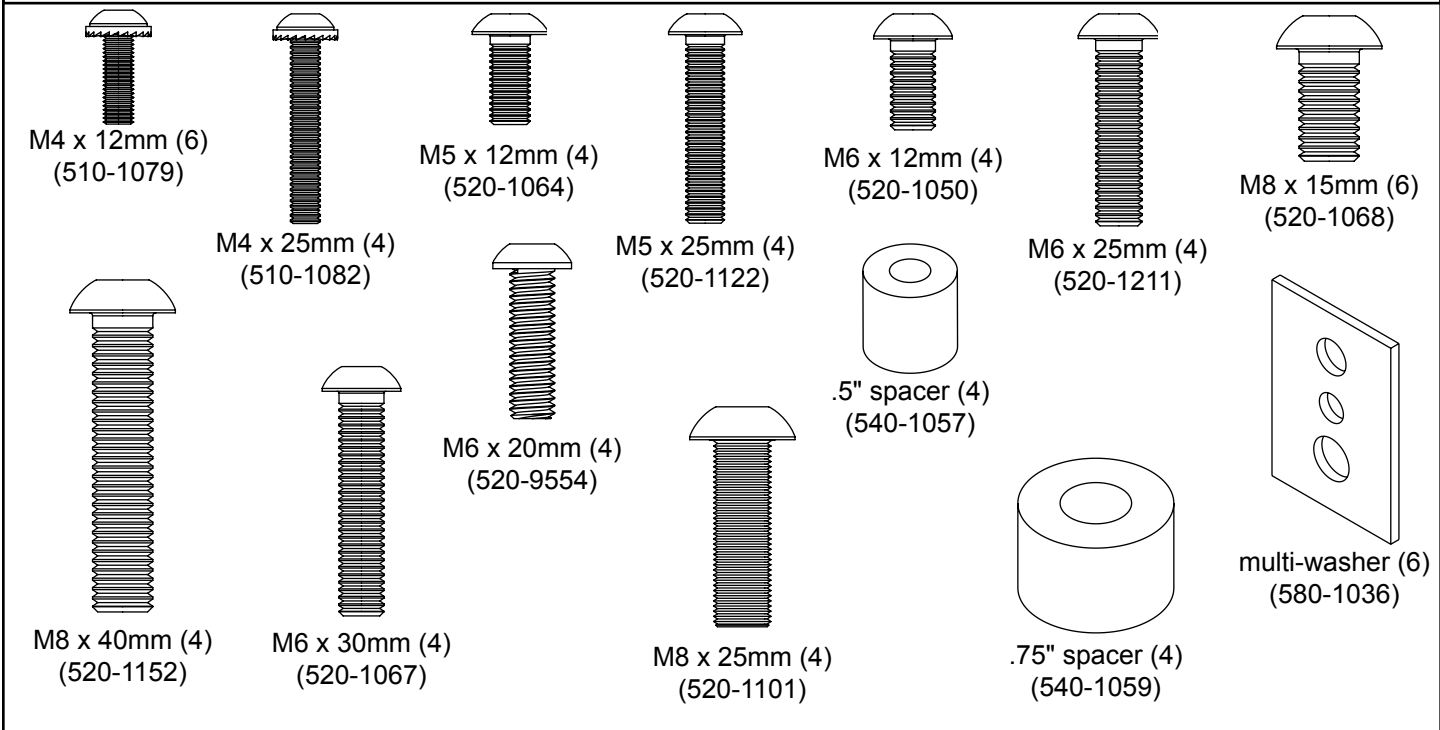

Installing Tilt Brackets

⚠ WARNING

- Tighten screws so adapter brackets are firmly attached. Do not tighten with excessive force. Overtightening can cause stress damage to screws, greatly reducing their holding power and possibly causing screw heads to become detached. Tighten to 40 in. • lb (4.5 N.M.) maximum torque.
- If screws don't get three complete turns in the screen inserts or if screws bottom out and bracket is still not tightly secured, damage may occur to screen or product may fail.

1 To prevent scratching the screen, set a cloth on a flat, level surface that will support the weight of the screen. Place screen face side down. Refer to screen manufacturers instructions or customer service, for removing any knobs, base, cover or screw(s) on the back of the screen to prepare mounting. These need to be removed to allow the tilt brackets to be attached. Select the small, medium, large or extra large screws from the baffled fastener pack then attach tilt brackets to screen following figure 1.1 or 1.2.

NOTE: Top and bottom mounting holes on screen must be used for attaching brackets.

NOTE: Be sure to attach tilt brackets with handles facing outward as shown below. Verify that all holes are properly aligned, and then tighten screws using a phillips screwdriver.

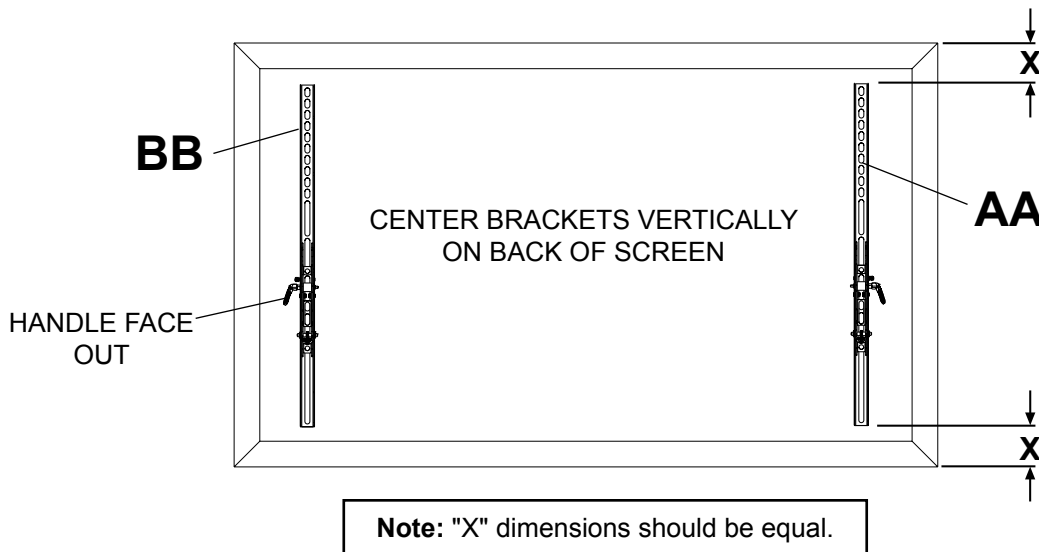

Notes:

- The number of fasteners used will vary, depending upon the type of screen.
- Multi-washers and spacers may not be used, depending upon the type of screen.
- Use the corresponding hole in the multi-washer that matches your screw size as shown.
- Slots in ST680 models are wider and require the use of the M8 washer.

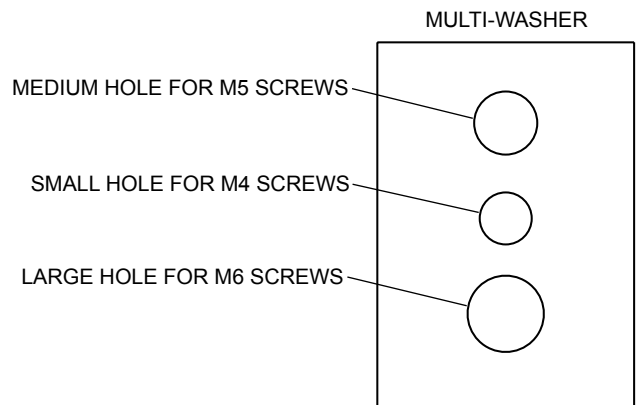

NOTE: For flat back screens proceed to step 1-1. For bump-out or recessed back screen skip to step 1-2.

For Flat Back Screen

1-1 Begin with the shortest length screw, hand thread through multi-washer and tilt bracket into screen as shown below. Screw must make at least three full turns into the mounting hole and fit snug into place. Do not over tighten. If screw cannot make three full turns into the screen, select a longer length screw from the baffled fastener pack. Repeat for remaining mounting holes, level brackets and tighten screws.

NOTE: Spacers may not be used, depending upon the type of screen.

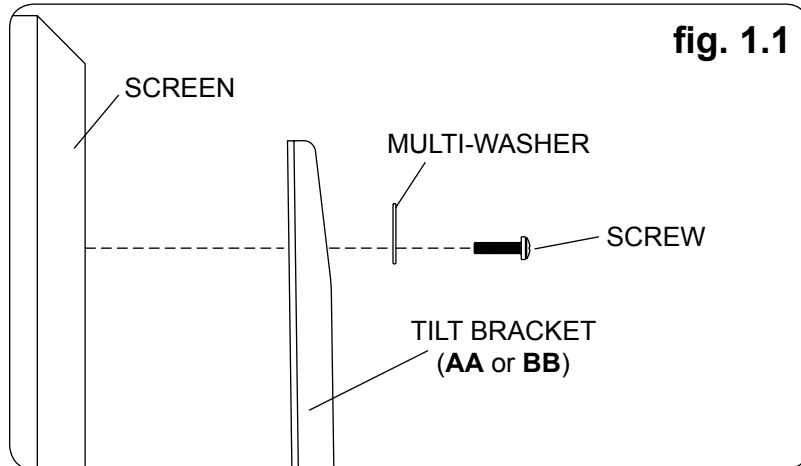

If you have any questions, please call Peerless customer care at 1-800-865-2112.

For Bump-out or Recessed Back Screen

1-2 Begin with longer length screw, hand thread through multi-washer, tilt bracket and spacer in that order into screen as shown below. Screw must make at least three full turns into the mounting hole and fit snug into place. Do not over tighten. If screw cannot make three full turns into the screen, select a longer length screw from the baffled fastener pack. Repeat for remaining mounting holes, level brackets and tighten screws.

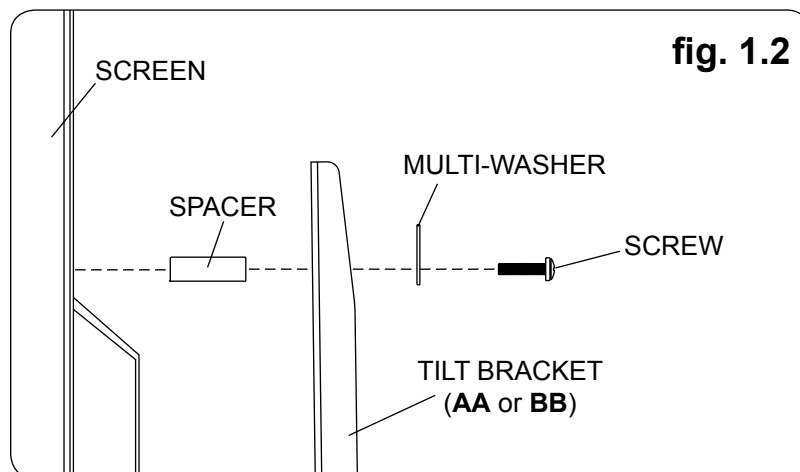

If you have any questions, please call Peerless customer care at 1-800-865-2112.

Mounting and Removing Flat Panel Screen

⚠ WARNING

- Always use an assistant or mechanical lifting equipment to safely lift and position the flat panel screen.
- Do not tighten screws with excessive force. Overtightening can cause damage to mount. Tighten screws to 40 in. • lb (4.5 N.M.) maximum torque.
- Be careful not to pinch fingers when pushing screen from the bottom.

2 Tension Adjustment of Ratchet Handle: Adjust tension in tilt brackets (**AA & BB**) by rotating ratchet handle. **NOTE:** If obstruction prevents ratchet handle from rotating, pull handle out while turning will allow handle to reposition without tightening. Release and turn handle to tighten or loosen.

Mounting Screen: Ratchet handle **must** be in the up or down position or interference will occur while hooking tilt brackets to wall plate. Slowly hook tilt brackets (**AA & BB**) onto wall plate and swing screen down as shown in fig. 2.1. Tilt bracket hooks must fully engage wall plate as shown in detail 1. Using security allen wrench (**CC**), turn safety/security screws on tilt brackets (**AA & BB**) clockwise till screw tip securely contacts wall plate as shown in cross section.

Installing Multiple Wall Plates and Screens

Multiple wall plates (sold separately) and adapter brackets can be used to create multiple screen displays.

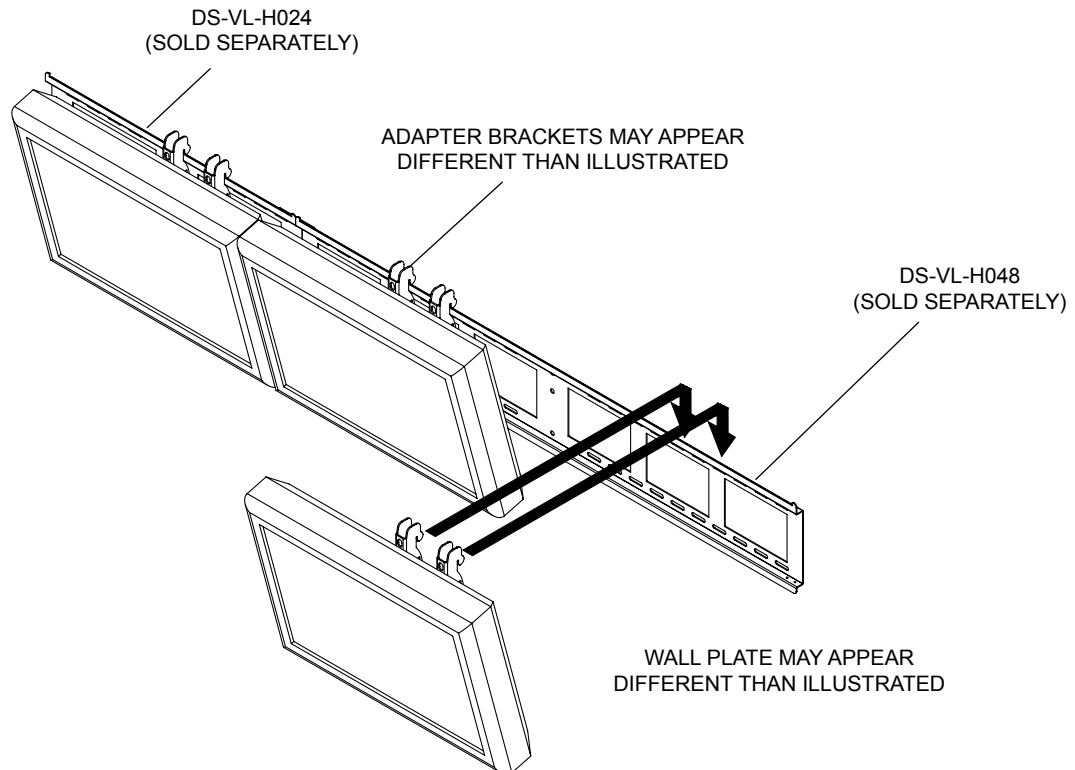
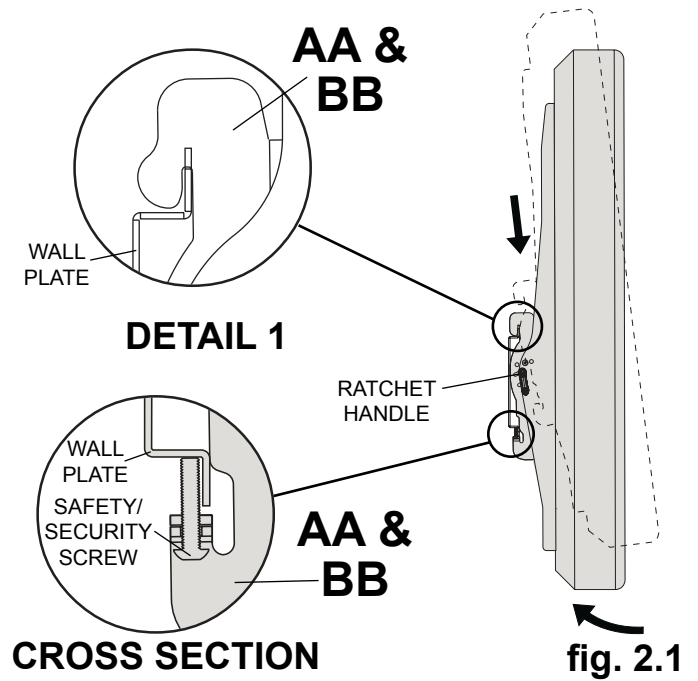

Screen Adjustment: Screen can be adjusted horizontally by loosening safety/security screws on tilt brackets (**AA & BB**) three full turns. Adjust screen as shown in figure 2.2. Tighten safety/security screws on tilt brackets using 4 mm allen wrench (**CC**) till screw tip securely contacts wall plate as shown in cross section.

Removing Screen: To remove screen from mount, loosen safety screws, swing screen away from mount, and lift screen off of mount.

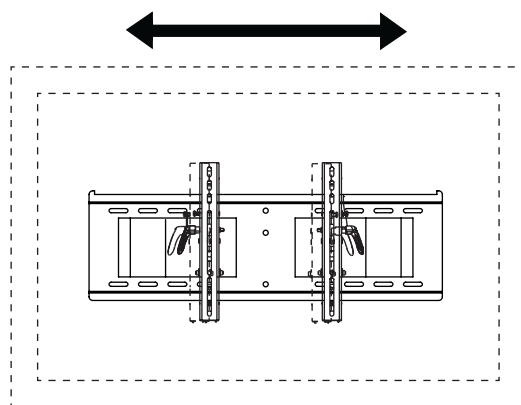

WALL PLATE MAY APPEAR DIFFERENT THAN ILLUSTRATED **fig. 2.2**

Adjusting the Tilt Angle of the Flat Panel Screen

3 For preset tilt angles use Increlok™ and for custom tilt angle use ratchet handle.

INCRELOK™: The screen can be locked into a pre-set tilt position of -5°, 0°, 5°, 10° or 15°. Use locator hole to find tilt position hole and tilt screen to align holes. Tighten IncreLok™ tilt locking screws on both tilt brackets to lock tilt as shown in detail 2.

Ratchet Handle: Loosen ratchet handle (refer to step 3 for tension adjustment of handle). Push or pull from top or bottom of screen to adjust tilt as shown in figure 3.1. The tilt can be adjusted to a maximum of 15° forward or 5° backward.

