

Installation and Assembly - Video Conferencing Shelf

Models: ACC319

MAXIMUM LOAD CAPACITY:
25.00 lb (11.4 kg)

IMPORTANT! Read entire instruction sheet before you start installation and assembly.

Parts List

DESCRIPTION	QTY.	PART #
A center mount	1	087-1039
B interface bracket	1	087-1047
C video conference shelf	1	009-1232
D M5 x 6 mm socket pin serrated washer head screw	4	510-1114
E square nut	2	530-1022
F 1/4 x 12 mm decorative screw	2	520-2325
G 4 mm security allen wrench	1	560-9646

Note: some parts may not appear exactly as illustrated.

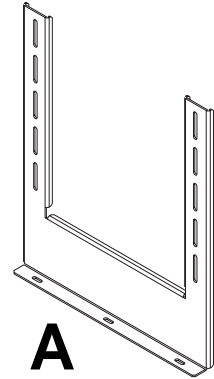

A

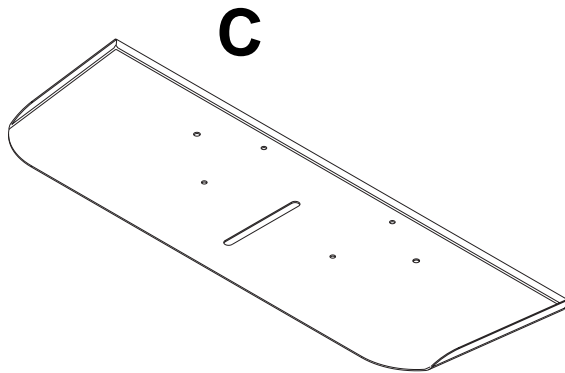

C

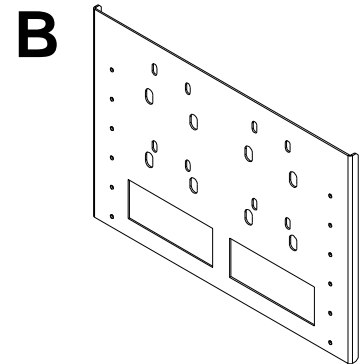

B

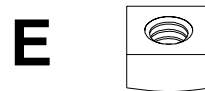

E



D

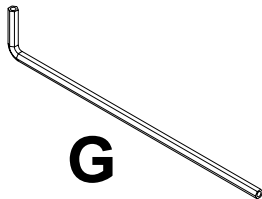

G

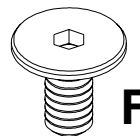

F

NOTE: If you are adding a new video conferencing shelf to an already assembled product, reverse steps up to the universal plate installation step (removing screen and adapter plate) following the main instruction sheet. Refer to Fig. 1.2 for reinstallation.

- 1** Attach interface bracket (B) onto center mount (A) using four M5 x 6 mm socket pin serrated washer head screws (D). Tighten screws using 4 mm security allen wrench (G).
Note: For best results use holes closest to the edge of the brackets as shown in Fig. 1.1.

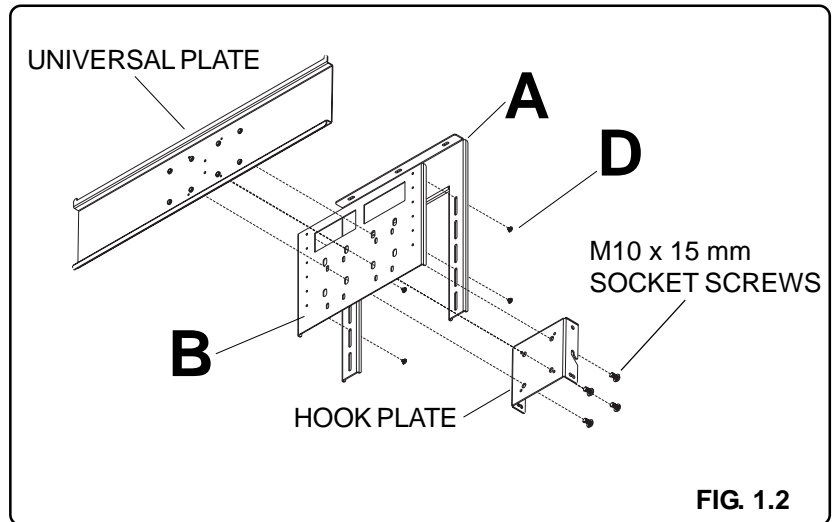
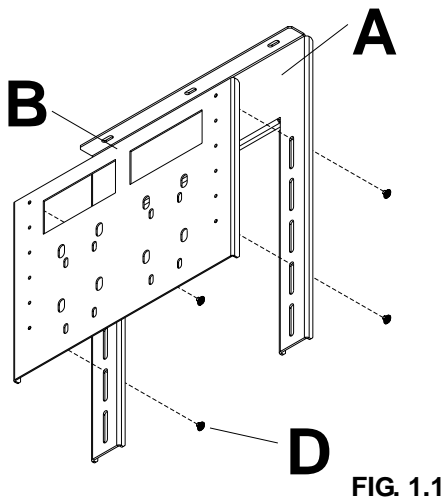

- 2** Attach video conference shelf (C) to center mount (A) using two 1/4 x 12 mm decorative screws (F) and two square nuts (E) as shown below.

