

ACCXT302

SMARTMOUNT XT™

Video Conferencing Shelf Accessory

Compatible with Peerless-AV™ SFX645(P), SFX650(P), SFX660(P), STX645(P)(L), STX650(P)(L) and STX660(P)(L) mounts

It's never been easier to integrate video conferencing into any setting thanks to the Video Conferencing Shelf Accessory from Peerless-AV™. It fits virtually any video conferencing camera and offers the choice of mounting it above or below the display. There won't be any worries about camera position, as it provides simple height adjustment for the perfect camera position. All while providing a clean, fully integrated style that looks great anywhere from the boardroom to the classroom.



Max load: 5lb (2.27kg)

FEATURES

- Universal, fits virtually any video conference cameras
- Compatible with Peerless-AV SFX645(P), SFX650(P), SFX660(P), STX645(P)(L), STX650(P)(L) and STX660(P)(L) mounts
- Simple height adjustment provides perfect camera positioning
- Mounts above or below the display
- Low profile design keeps the low profile aspect of today's slim mounts
- Cable management slot keeps cables and cords neatly organized

■ **UNIVERSAL FIT**
Easily accommodates most video conferencing cameras

■ **CLEAN INSTALLATION**
Cable management slot keeps cables and cords neat

■ **TEMPERATURE REGULATION**
Ventilation slots in camera shelf help keep camera cool

■ **LOW-PROFILE**
Does not add any depth to the installation of the mount

■ **PERFECT POSITIONING**
Camera shelf can be raised or lowered above or below the display



Shown attached to Peerless-AV STX645 mount

RoHS



INTEGRATED
PARTNER
PROGRAM

Contact your Peerless-AV sales representative for more information

CLICK: www.peerless-av.com

CALL: 800.865.2112

FAX: 800.359.6500

peerless-AV™

ACCXT302 SmartMountXT™ Video Conferencing Shelf Accessory compatible with Peerless-AV SFX645(P), SFX650(P), SFX660(P), STX645(P)(L), STX650(P)(L) and STX660(P)(L) mounts

Product Specifications

	DIMENSIONS (W x H x D)	PRODUCT WEIGHT	LOAD CAPACITY	FINISH	AVAILABLE COLORS
ACCXT302	9.00" x 7.57"-12.00" x 5.94" (229 x 192-305 x 151mm)	1.54lb (0.7kg)	5lb (2.27kg)	Powder coat	High Gloss Black

Package Specifications

	PACKAGE SIZE (W x H x D)	PACKAGE SHIP WEIGHT	PACKAGE UPC CODE	PACKAGE CONTENTS	UNITS IN PACKAGE
ACCXT302	6.375" x 3.25" x 13.56" (162 x 83 x 344mm)	2.1lb (0.95kg)	735029279938	Universal video conferencing shelf mount, mount attachment hardware, installation instructions	1

All dimensions = inch (mm)

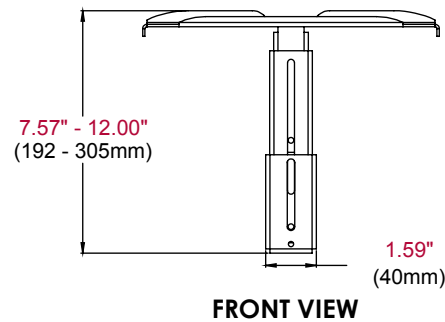
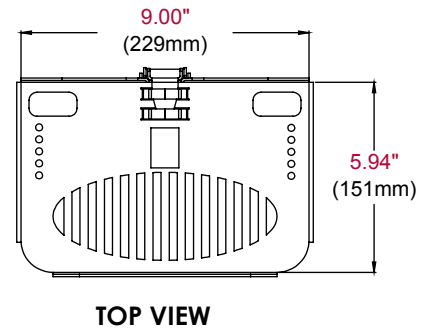
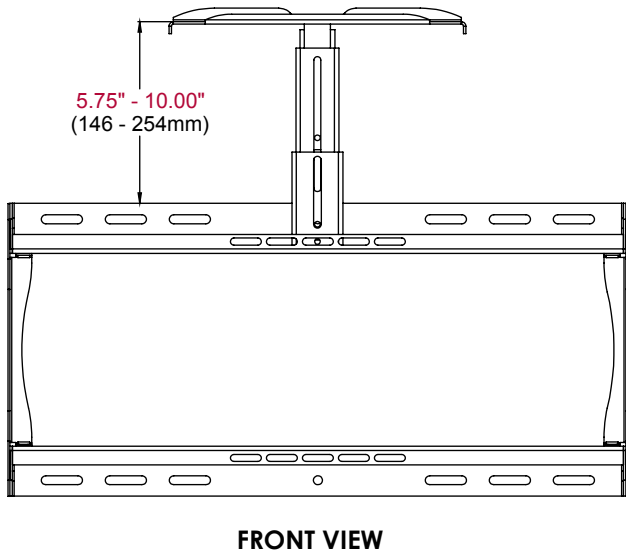

ARCHITECTS SPECIFICATIONS

The SmartMountXT™ Video Conferencing Shelf Accessory shall be a Peerless-AV model ACCXT302 and shall be located where indicated on the plans. It shall feature scratch resistant black fused epoxy finish. Assembly and installation shall be done according to instructions provided by the manufacturer.