



SpeechLine Digital Wireless

Antenna solutions and recommendations
on antenna mounting for the SL Rack Receiver DW



Contents

Antenna solutions for SpeechLine Digital Wireless	3
Antenna setup planning for SpeechLine Digital Wireless.....	3
Mounting instructions for the AWM 2 and AWM 4	3
Antenna mounting options	4
Option 1:	
Connecting the AWM 2/AWM 4 directly to the receiver(s).....	4
Option 2:	
Combining multiple links to one AWM 2/AWM 4.....	6
Option 3:	
Rack mounting - front.....	10
Option 4:	
Rack mounting - rear	10
Further important information on antenna usage	11
Reflecting surfaces.....	11
Blocking effects from other transmitters	12



Antenna solutions for SpeechLine Digital Wireless

This document gives an overview over several possibilities of mounting and using antennas for a SpeechLine Digital Wireless system. Furthermore, this document provides recommendations on several aspects which should be considered for the different antenna solutions.

Antenna setup planning for SpeechLine Digital Wireless

When planning the installation of SpeechLine Digital Wireless rack receivers and antennas for each room, observe the following guidelines:

- ▷ Mount all SpeechLine Digital Wireless receivers of one room together in one rack.
- ▷ Make sure to have a direct line of sight between the transmitters and the receiving antennas.
- ▷ Depending on the room characteristics there are several options how to install the receiving antennas. We recommend the following options in this order:
 - Option 1: remotely mounted using the AWM 2 for one receiver or AWM 4 for two receivers
 - Option 2: remotely mounted using the AWM 2 or AWM 4 with multiple receivers combined (passive combiner)
 - Option 3: mounted in a rack (front)
 - Option 4: mounted in a rack (rear)
- ▷ When mounting antennas remotely, observe the minimum distance to possibly existing DECT access points and also take into account the cable lengths.
- ▷ Always switch all receivers on and off with a common power supply (e.g. a multi-outlet power strip with a central on/off switch) in order to achieve the best performance of a system.



For further technical details and recommendations on the four options please refer to the chapter „Antenna mounting options“ starting on the next page.

Mounting instructions for the AWM 2 and AWM 4

When using the AWM 2 or AWM 4 please observe the respective mounting instructions. You will find them in the download sections of the respective product pages:

www.sennheiser.com/awm-2

www.sennheiser.com/awm-4



Antenna mounting options

As mentioned above, there are multiple possibilities for remote mounting the antennas. In the following, we will explain the most common options with additional recommendations in order of preference.

Option 1:

Connecting the AWM 2/AWM 4 directly to the receiver(s)

You can connect one receiver directly to one AWM 2 antenna wall mount or you can connect two receivers directly to one AWM 4 antenna wall mount.

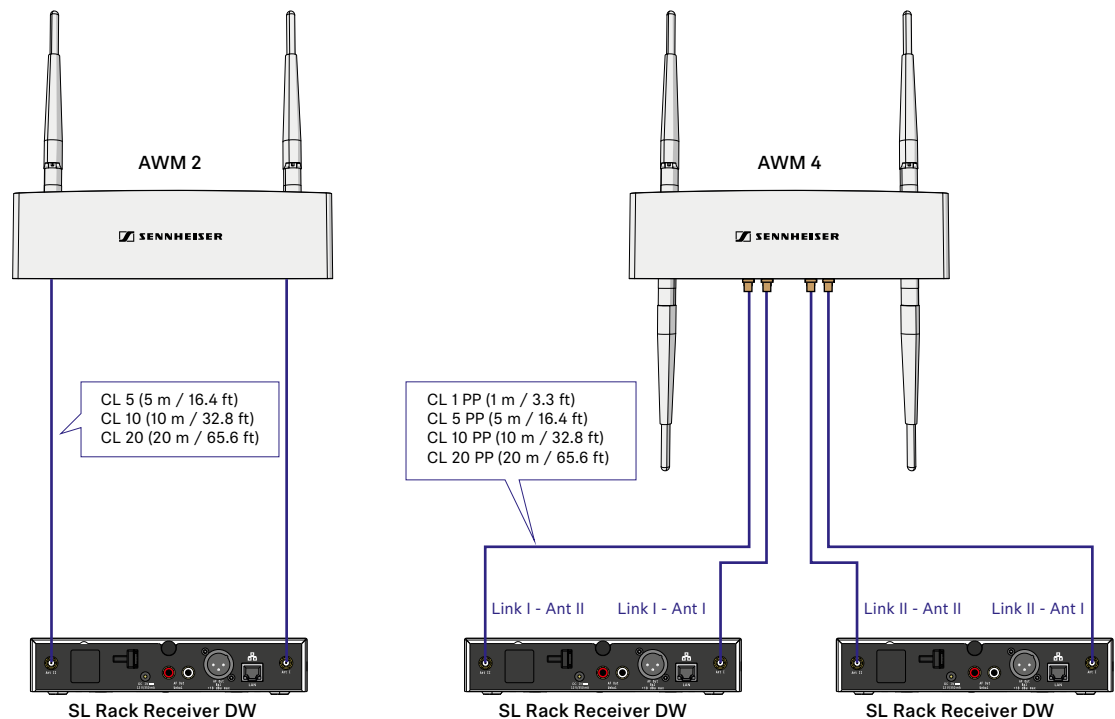

Signal loss due to extension cables

In this scenario, using extension cables for remote antenna mounting results in a loss of transmission power, depending on the cable length. You can compensate this signal loss by configuring the transmission power of the receiver accordingly.

▷ Observe the following minimum transmission power settings (SL Rack Receiver DW: **System Settings** menu -> **RF Power**) for the respective cable lengths:

- Cable length of **5 m** -> at least **level 1**
- Cable length of **10 m** -> selected level **+1**, at least **level 2**
- Cable length of **20 m** -> selected level **+1**, at least **level 3**
- Cable length of **25 m** and longer -> selected level **+2**, at least **level 4**

▷ The Sennheiser CL antenna cables have the following attenuation:

CL 5	2.5 dB	CL 1 PP	0.5 dB
CL 10	5 dB	CL 5 PP	2.5 dB
CL 20	10 dB	CL 10 PP	5 dB
		CL 20 PP	10 dB



Remote antenna distances and line of sight

If you are using multiple antenna wall mounts (AWM 2/AWM 4) in one room or if individual installation and mounting of the antennas is desired, please observe the following aspects:

- ▷ Position all antennas as close as possible to each other.
- ▷ Make sure that the distances between all antennas are all equal and the same as on the back of the receiver or on the AWM 2 antenna wall mount.
- ▷ If possible, group the antennas as follows:
 - All **A** antennas from the receivers' **ANT I** sockets in one group according to the aforementioned requirements
 - All **B** antennas from the receivers' **ANT II** sockets in one group according to the aforementioned requirements

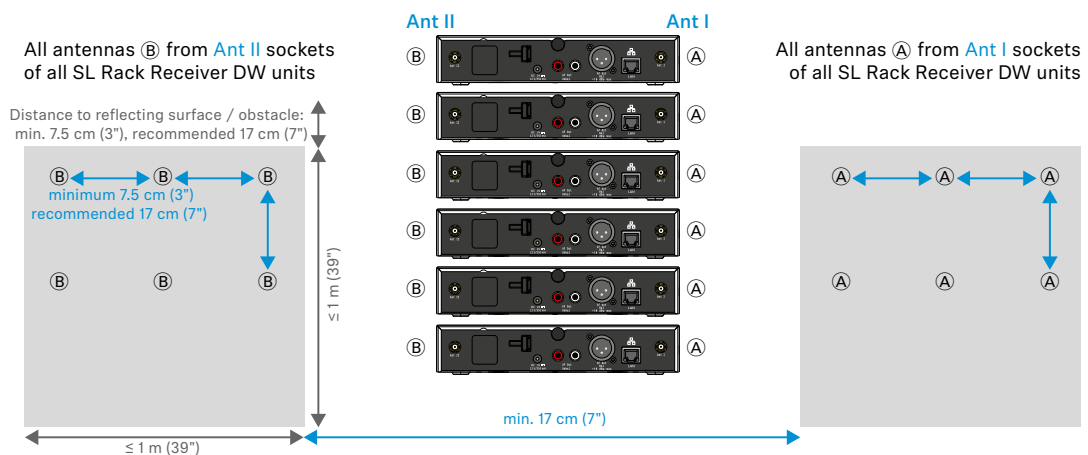

- ▷ When using multiple AWM 2/AWM 4 antenna wall mounts, make sure that the distances between all antennas are equal:

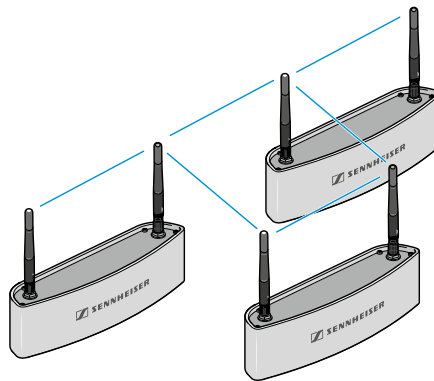

- ▷ If possible, position the antennas so that there is a direct line of sight (without obstacles) between the transmitters and the antennas.

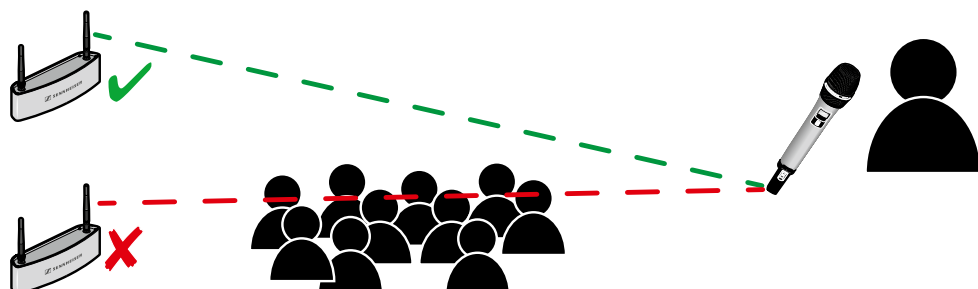



Option 2: Combining multiple links to one AWM 2/AWM 4

With this variant, you can use passive antenna splitters (SL PASC 2 or SL PASC 4) together with the AWM 2 or AWM 4 to combine the antenna signals from multiple receivers. This reduces the number of antenna cables required to a minimum.

Combining up to 2 links using the AWM 2 and SL PASC 2

The following illustration shows an example of how to combine up to 2 links with one AWM 2 antenna wall mount. This reduces the number of antenna cables required from 4 to 2.

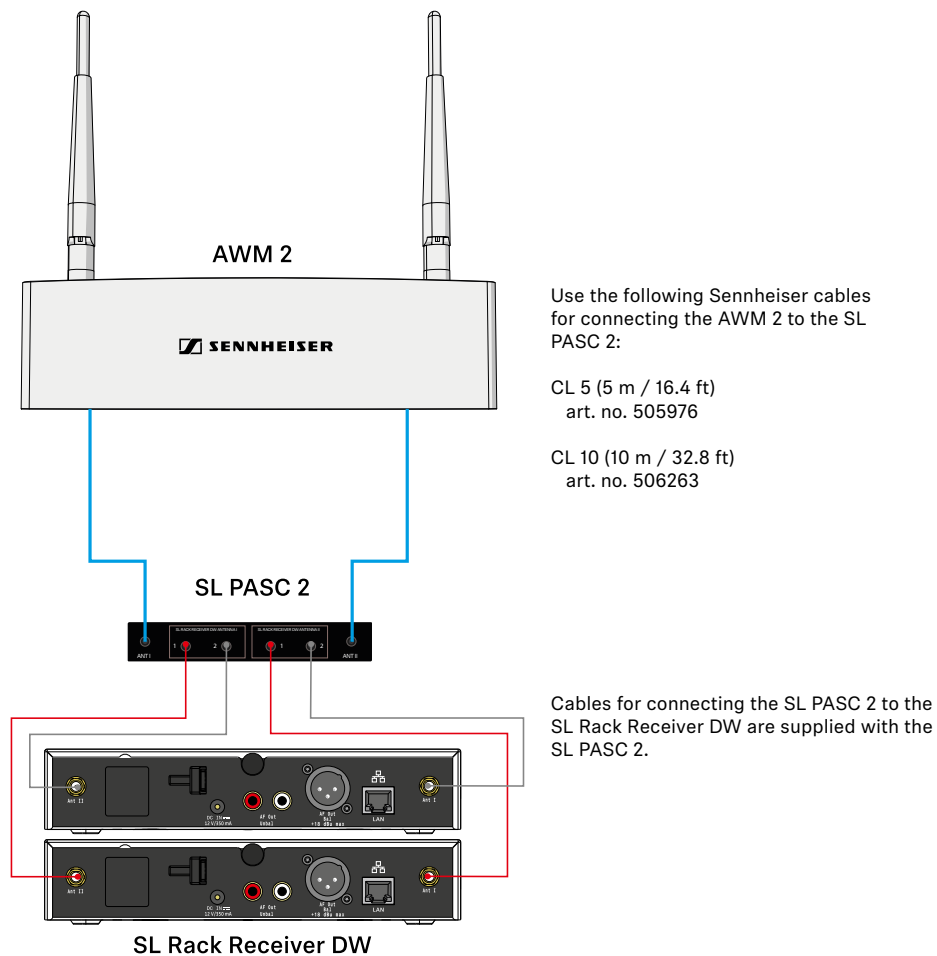

- ▶ Please observe the information below on the length of the extension cables:
„Signal loss due to extension cables and antenna splitters“



Combining up to 4 links using the AWM 2 and the SL PASC 4

The following illustration shows an example of how to combine up to 4 links with one AWM 2 antenna wall mount. This reduces the number of antenna cables required from 8 to 2.

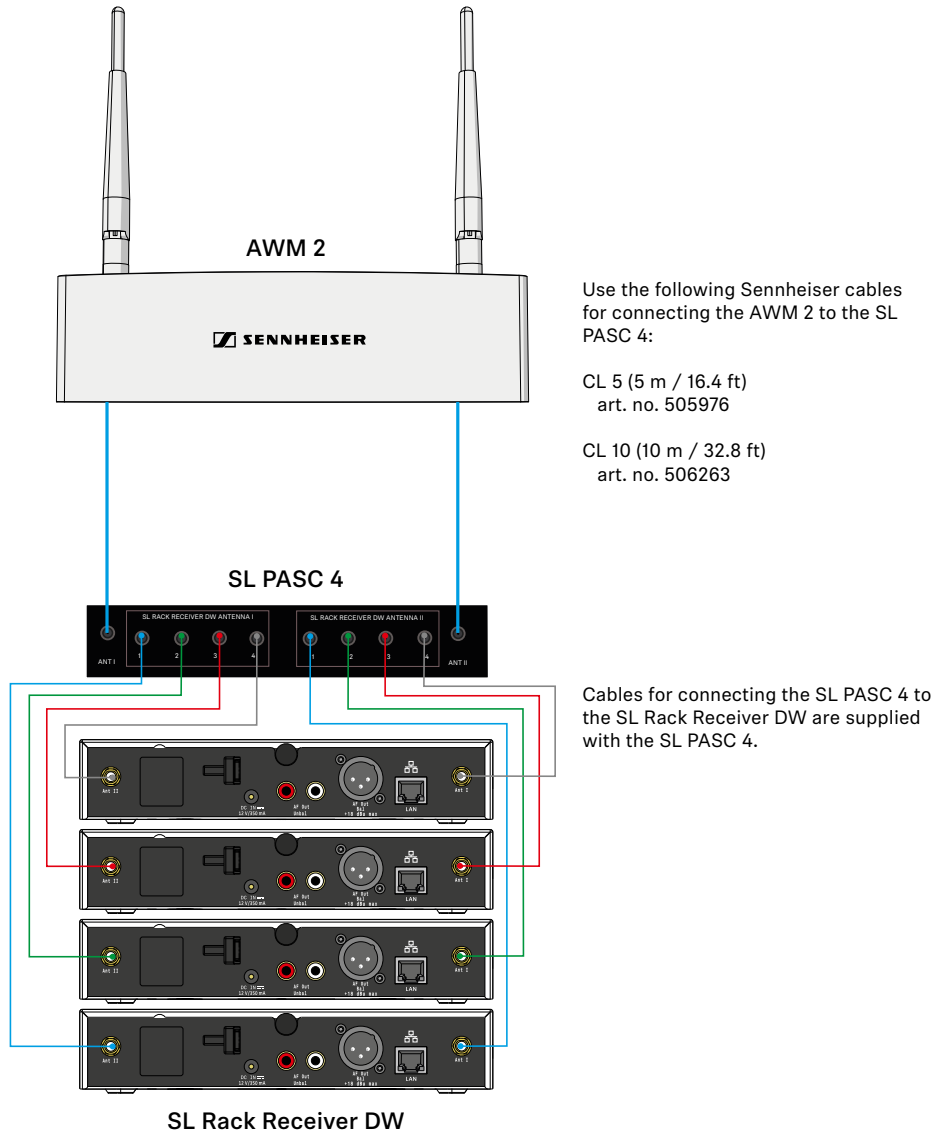

- ▷ Please observe the information below on the length of the extension cables:
„Signal loss due to extension cables and antenna splitters“



Always combine all antenna sockets ANT I of all receivers and all antenna sockets ANT II of all receivers respectively to one of the two antennas of the AWM 2. If you are using only 3 of the 4 connections on the antenna splitter, you should close the unused connection with a terminating resistor (50 Ω) to minimize interfering signals and maximize transmission power.



Combining up to 8 links using the AWM 4 and the SL PASC 4

The following illustration shows an example of how to combine up to 8 links with one AWM 4 antenna wall mount. This reduces the number of antenna cables required from 16 to 4.

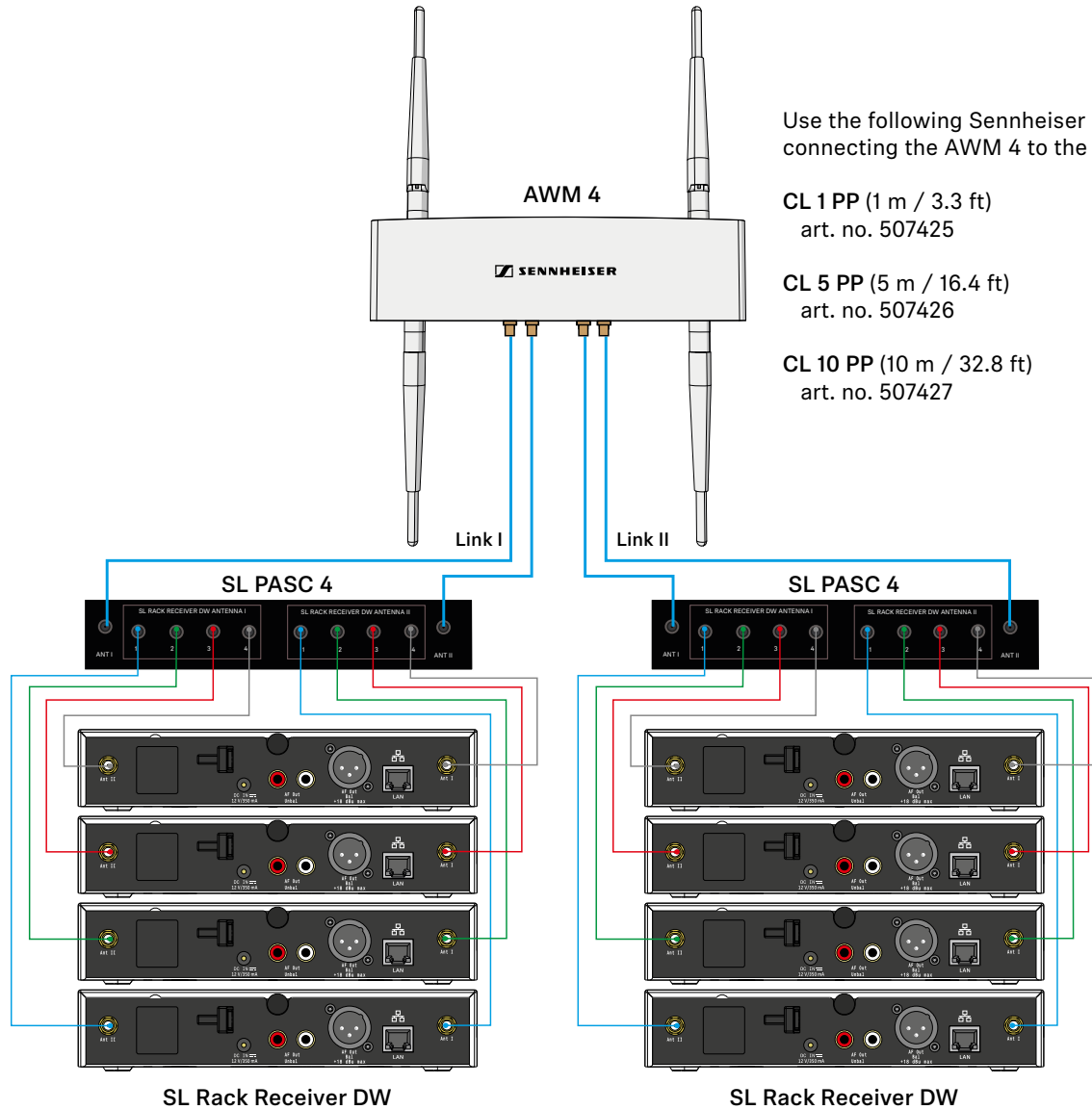

Cables for connecting the SL PASC 4 to the SL Rack Receiver DW are supplied with the SL PASC 4.

- ▶ Please observe the information below on the length of the extension cables:
„Signal loss due to extension cables and antenna splitters“



Always combine all antenna sockets ANT I of up to four receivers and all antenna sockets ANT II of up to four receivers respectively to the two sockets of one link of the AWM 4. If you are not using all connections on the antenna splitter, you should close the unused connections with a terminating resistor (50 Ω) to minimize interfering signals and maximize transmission power.



Signal loss due to extension cables and antenna splitters

In this scenario, the use of extension cables and antenna splitters with a remotely mounted antenna may result in loss of transmission power, depending on the cable length.

You can compensate this signal loss by configuring the transmission power of the receiver accordingly. Observe the following minimum transmission power settings (SL Rack Receiver DW: **System Settings menu -> RF Power**) for the respective cable lengths. The antenna splitter causes about as much signal loss as a cable length of 15 m. These losses must be included in the calculation of the transmission power level.

We recommend the following cable lengths in combination with the antenna splitter:

- Receiver to splitter: 1 m -> splitter to AWM 2/4: 1 m
- Receiver to splitter: 1 m -> splitter to AWM 2/4: 5 m
- Receiver to splitter: 1 m -> splitter to AWM 2/4: 10 m
- Receiver to splitter: 5 m -> splitter to AWM 2/4: 1 m
- Receiver to splitter: 5 m -> splitter to AWM 2/4: 5 m
- Receiver to splitter: 10 m -> splitter to AWM 2/4: 1 m



Cables longer than 10 m are not recommended for this variant.

This results in the following **transmission power levels** to be set in the menu of the receiver or simultaneously for all receivers in the Sennheiser Control Cockpit software:

- 5 m cable length plus splitter -> at least **level 2**
- 10 m cable length plus splitter -> at least **level 3**

The Sennheiser CL antenna cables have the following attenuation:

CL 5	2.5 dB	CL 1 PP	0.5 dB
CL 10	5 dB	CL 5 PP	2.5 dB
CL 20	10 dB	CL 10 PP	5 dB
		CL 20 PP	10 dB

Direct line of sight

- ▷ If possible, position the antennas so that there is a direct line of sight (without obstacles) between the transmitters and the antennas.

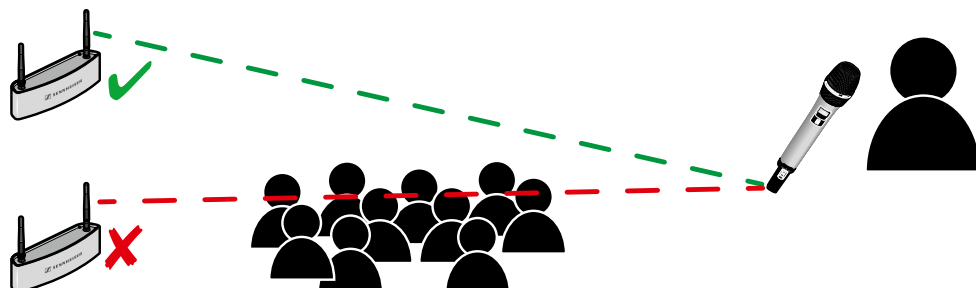



Option 3: Rack mounting - front

If you wish to install the antennas together with the receivers in a rack, we recommend mounting the antennas on the front side of the rack using the GA 4 mounting kit.

- ▷ Always leave 1 U of space between receivers and antennas.
- ▷ Position the antennas at an angle of about 45°.

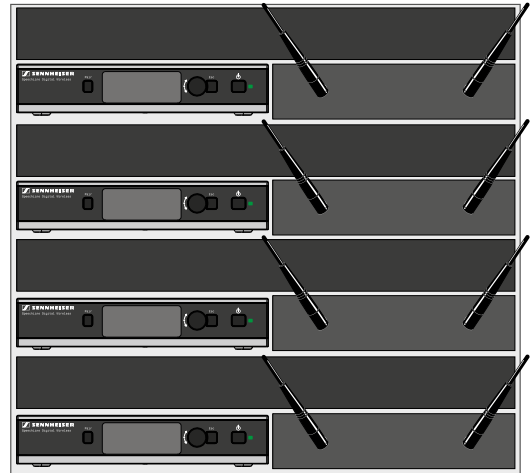

Option 4: Rack mounting - rear

If you cannot mount the antennas at the front of the rack (option 3), you can also mount them at the rear of the receiver in the rack. When mounting, observe the following information.

- ▷ Position the antennas so that they point at a 180-degree angle away from the receiver.
- ▷ Run all cables close to the receivers to prevent the cables from interfering with the antenna reception. Use the cable grip.
- ▷ For best system performance, make sure that the antennas are not covered or shielded by blocking obstacles such as cables, metal plates, or cases.
- ▷ In this case, and if possible, make sure that there is a direct line of sight between the transmitters and the receivers for best possible RF performance.

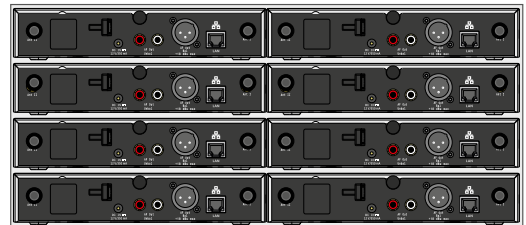



Further important information on antenna usage

Reflecting surfaces

Electrically conducting surfaces (e.g. ceilings with metal constructions) can reflect the RF signal.

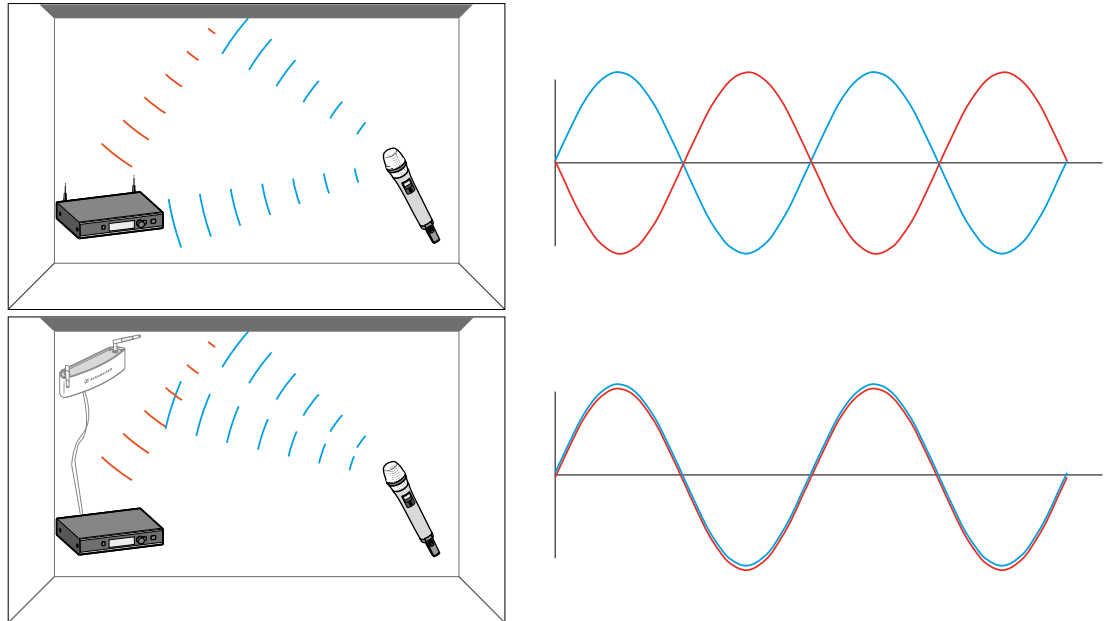

The signal is reflected by the electrically conducting surface. At worst, the blue signal and the red reflected signal are out of phase when they reach the receiver so that the two signals cancel each other out.

- ▷ If you have electrically conducting surfaces in a room, make sure to position the receiver or the antenna wall mounts so that such reflection effects are avoided.
- ▷ If you have a reflecting ceiling, this can be achieved by positioning the antennas closer to the ceiling.



Blocking effects from other transmitters

As with all wireless microphone systems, suboptimal positioning of transmitters can lead to blocking effects. To avoid this, please follow these recommendations:

- ▷ Position DECT telephone or DECT access points at least 7 m from the antennae.
- ▷ Position other wireless devices such as mobile phones at least 1 to 2 m from the antennae.
- ▷ When transmitters are currently in use, **you must not position any other transmitters in the blocking area.** If you must position them there, switch them off.

Rule of thumb for distance from the blocking area:

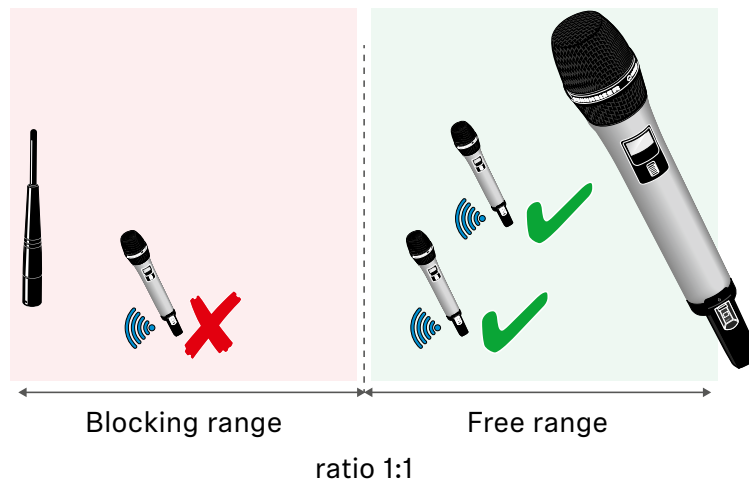

Example:

