

# ***ClearOne***<sup>®</sup>

**BluePort NS-BP200 - Wireless Audio Gateway**

## INSTALLATION GUIDE



<b>Telephone</b>	1.800.283.5936 1.801.974.3760
<b>FAX</b>	1.801.974.3669
<b>E-mail</b>	tech.support@clearone.com
<b>On the Web</b>	www.clearone.com

**BLUEPORT WIRELESS AUDIO GATEWAY  
INSTALLATION GUIDE**

**CLEARONE DOCUMENT  
800-225-014-01 - Oct. 03, 2011 (Rev. 1.0)**

© 2011 ClearOne All rights reserved. No part of this document may be reproduced in any form or by any means without written permission from ClearOne. ClearOne reserves specific privileges.

Information in this document is subject to change without notice.

U.S Patent Pending

USPTO 61/384,581 IN WALL MOUNTED WIRELESS INTERFACE  
FOR AUDIO VIDEO DISTRIBUTION SYSTEM

# Table of Contents

## PRODUCT OVERVIEW

Application .....	1
Supported Devices .....	1

## CONNECTIONS AND CONTROLS

Electrical Connections .....	2
Zone Name Selector .....	2
Status LED .....	2
Reset Button .....	2
Physical Characteristics.....	2
Powering the BluePort .....	3
Connection Diagrams.....	4

## PAIRING THE WIRELESS DEVICE

Zone Name Selector Switch .....	7
How to Pair with the BluePort .....	7
Reconnecting to a Previously Paired BluePort .....	8
Restoring To Factory Defaults.....	8

## COMPLIANCE AND SERVICE

Compliance Overview .....	9
Service and Support .....	9
Technical Support .....	9
Sales .....	9
Techsales .....	9
Product Returns .....	9

## Product Overview

The NS-BP200 BluePort is a simple to use digital wireless audio gateway that enables you to transmit digital audio from a source with *Bluetooth*® A2DP support to your DigiLinX, NaimNet, VIEW™, Musica™ or Quartet™ multi-room system with a compatible EIM connection. The BluePort is fully *Bluetooth* v2.0 compliant.

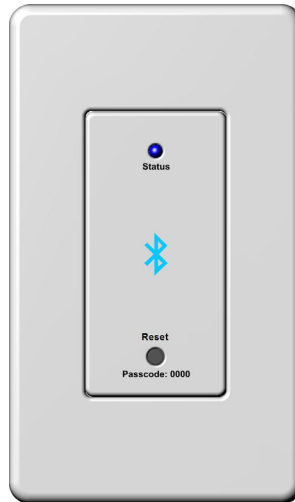

## APPLICATION

The BluePort acts as a receiver to connect the output from your *Bluetooth* wireless audio device to your connected audio system. The nominal working distance of 33 feet between the BluePort and the wireless source device may be greater or shorter depending on wall construction, electrical interference, and the output power of the portable device.

## SUPPORTED DEVICES

The BluePort works with devices that support the A2DP *Bluetooth* profile. Refer to your wireless device manual to determine if it supports A2DP.

# Connections and Controls

## ELECTRICAL CONNECTIONS

1x RJ45 connection with EIM (Expansion Interface Module used with SpeakerLinX, Musica Keypad, NaimNet and Quartet Keypad. Optional power injector may be required).

1x RJ45 connection with AP (Audio Port connection used with SpeakerLinX, TLA250, or Musica and Quartet Keypad).

## ZONE NAME SELECTOR

The Zone Name Selector is a 16-position rotary switch (labeled Set ID that is used to select which of 16 zone names the BluePort uses to identify itself to paired wireless audio devices.

## STATUS LED

The small LED illuminates to indicate the BluePort connection and streaming status. For more information about the LED status, refer to the Pairing the Wireless Device later in this guide.

## RESET BUTTON

Pressed to initiate the connection between the BluePort and the external audio device. Also used to restore the BluePort to factory defaults

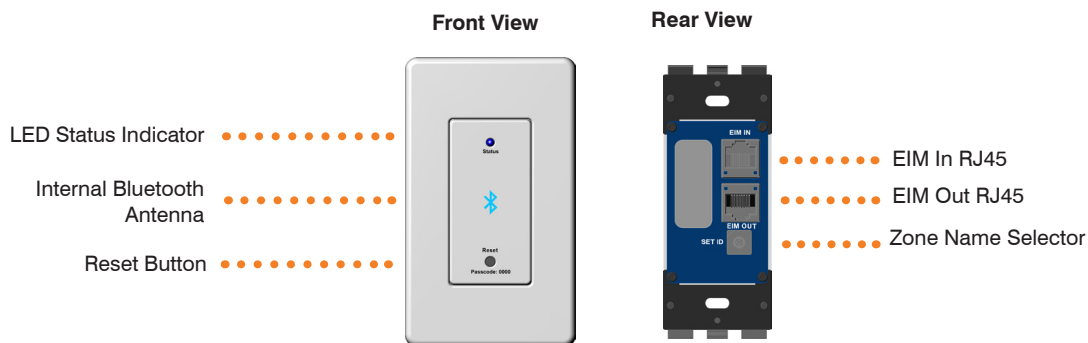

## PHYSICAL CHARACTERISTICS

### Dimensions (Excluding Connectors)

In-Wall Dimensions

1-3/4" x 2-13/16" x 1-1/4"

(45mm x 71mm x 32mm)

External Dimensions

2-3/4" x 4-5/8" x 1-1/3"

(45mm x 71mm x 32mm)

The unit is designed to fit in a standard single gang box, wired from behind.

## POWERING THE BLUEPORT

The BluePort is powered either directly from the system connected to the BluePort using the EIM Input, or by an optional Power Injector. The following table specifies the systems that can connect to the BluePort and whether or not a Power Injector is required to power the unit.

Company	Brand	Model(s)	Power Injector
NetStreams	DigiLinX	NS-SL220, NS-SL250, NS-SL251, NS-SL254, NS-SLX300, NS-SL9250-CS	Optional
NetStreams	DigiLinX	(NS-SL220, NS-SL250, NS-SL251, NS-SL254, NS-SLX300, NS-SL9250-CS) With any NS-KL201, NS-KL101, NS-IRL1	Required
NetStreams	DigiLinX	TLA250	Required
NetStreams	Quartet	NS-Q4000	Required
NetStreams	Musica	NS-MU5066, NS-MU4602, NS-MU4601, Musica Keypad	Required
ClearOne	VIEW	SL251, SL254, SL9250-CS, SLX300	Optional
ClearOne	VIEW	(SL251, SL254, SL9250-CS, SLX300) With any NS-KL201, NS-KL101, NS-IRL1	Required
NAIM Audio	NaimNet	NNP01, NNP02, NNP02-DC	Optional
NAIM Audio	NaimNet	(NNP01, NNP02, NNP02-DC) With any NS-KL201, NS-KL101, NS-IRL1	Required

Shown below are the rear views of the BluePort and the Power Injector.

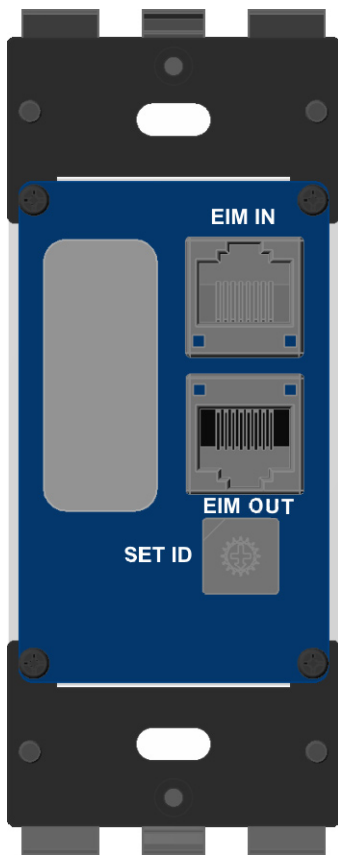

## CONNECTION DIAGRAMS

The following pages contain diagrams showing the connection layouts of various supported devices with the BluePort.

### Connecting a BluePort to a SpeakerLinX (No KeyLinX)

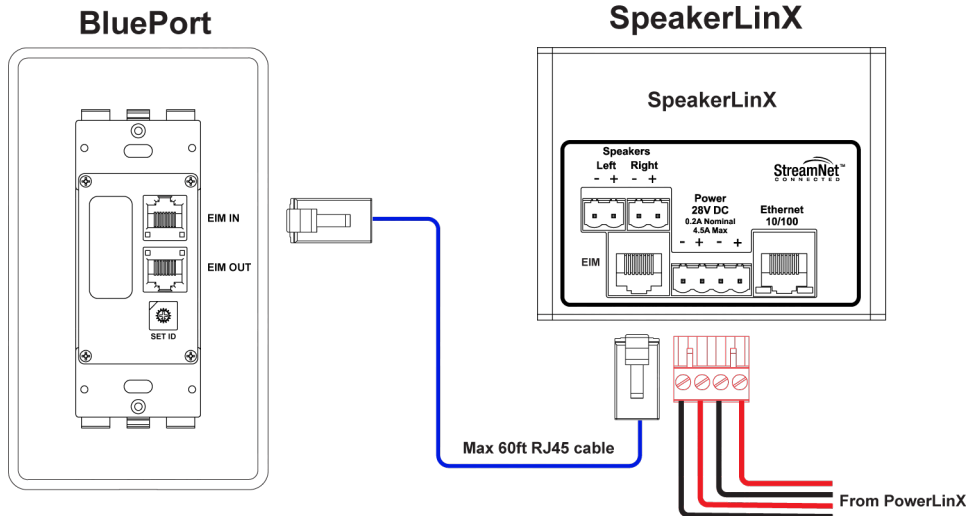

### Connecting a BluePort to a SpeakerLinX (With KeyLinX)

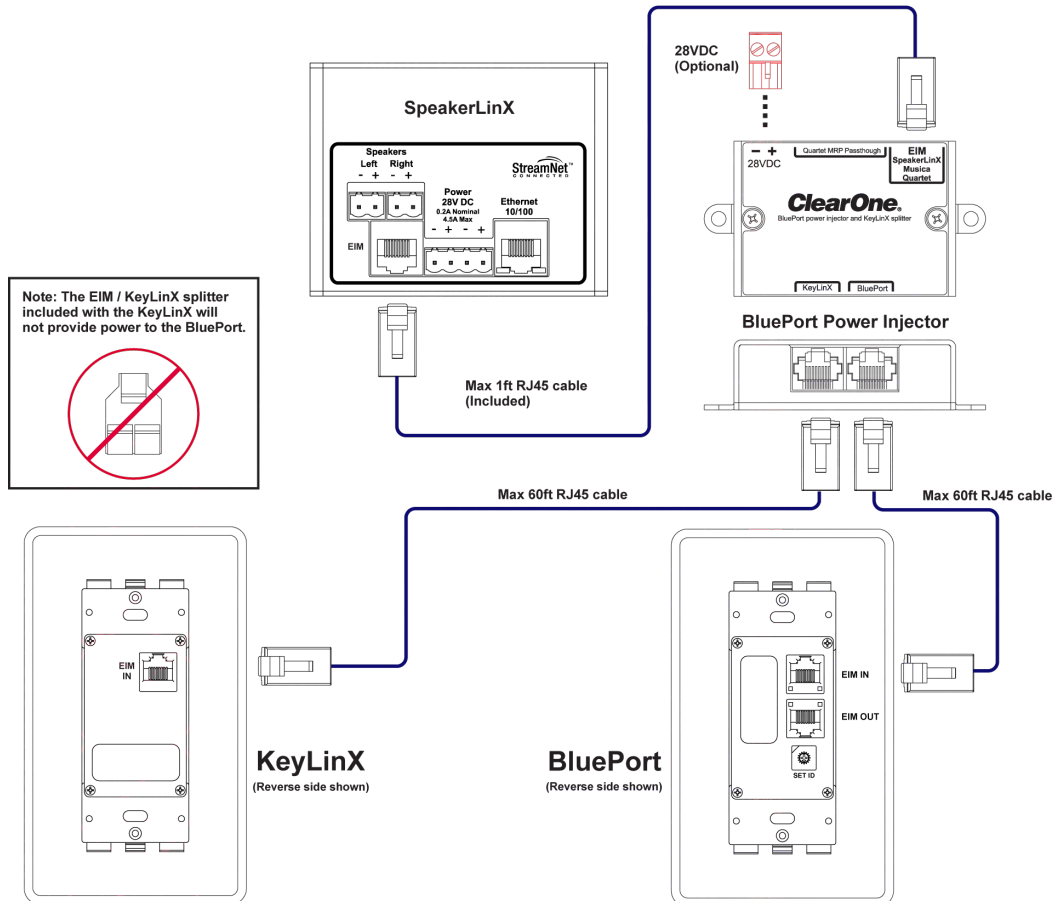

## Connecting an AP450 to the BluePort

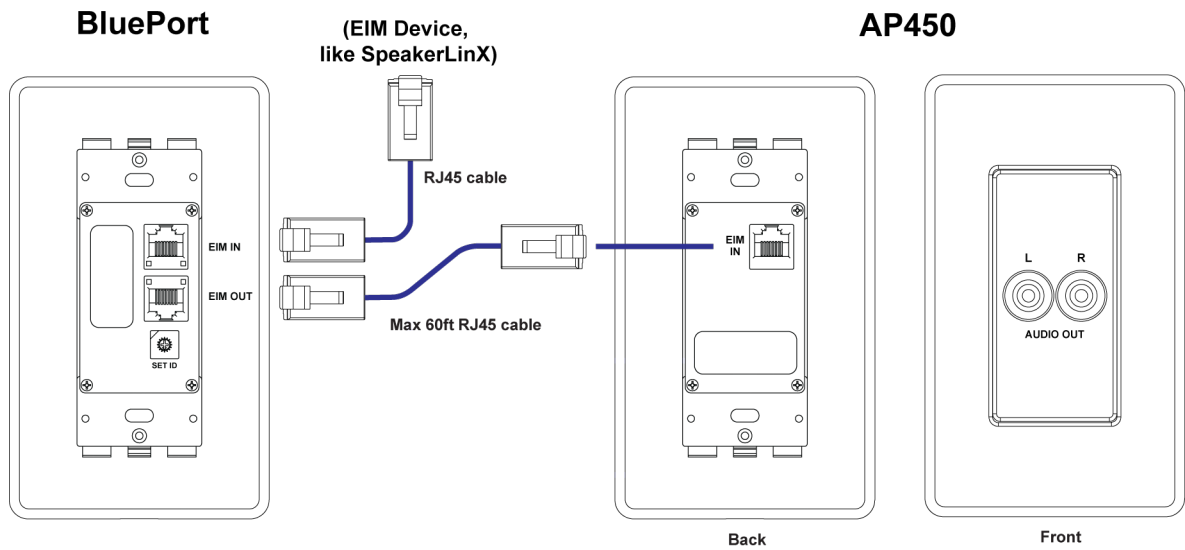

## Connecting a BluePort to a TLA250

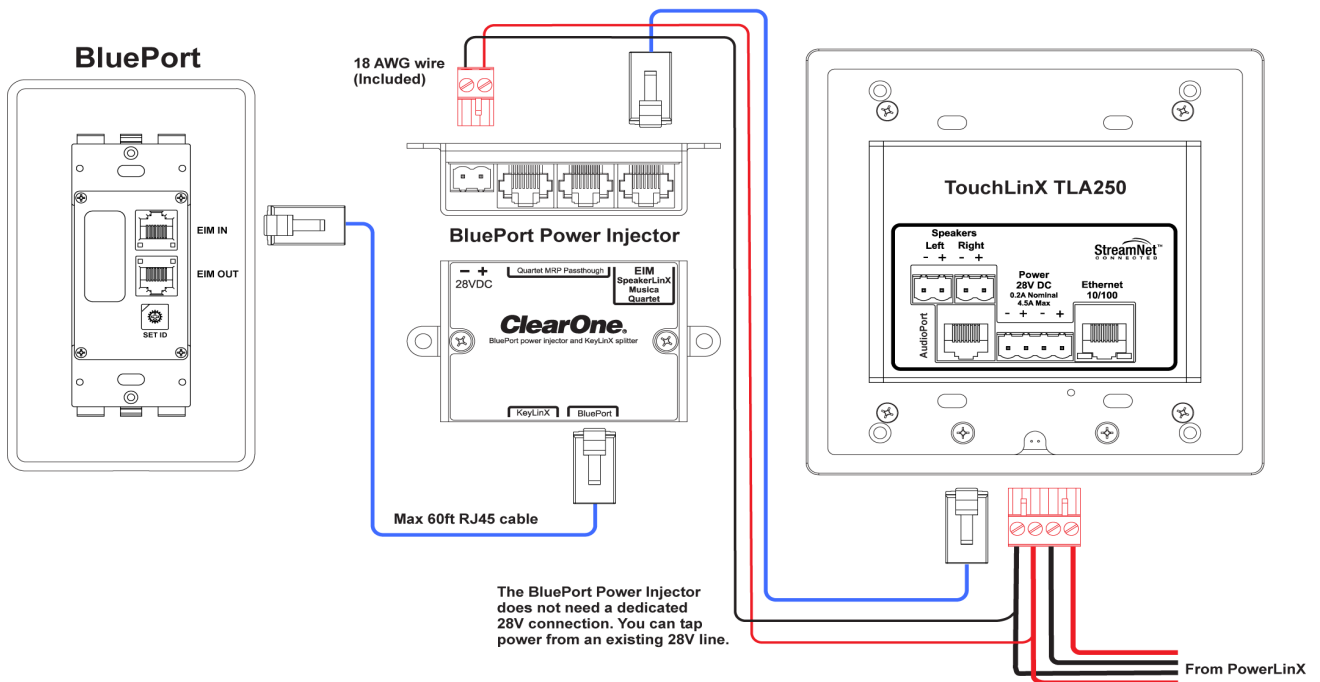



## Connecting the BluePort to a Musica Keypad

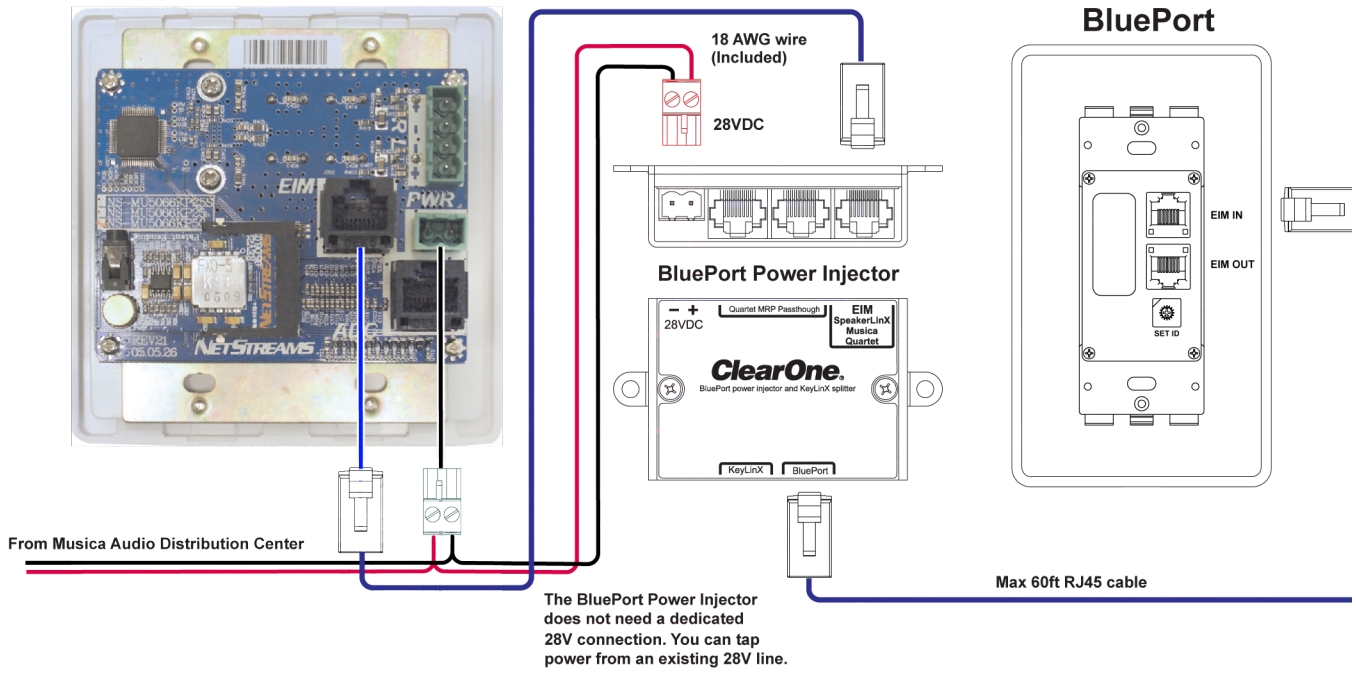

## Connecting the BluePort to a Quartet Keypad

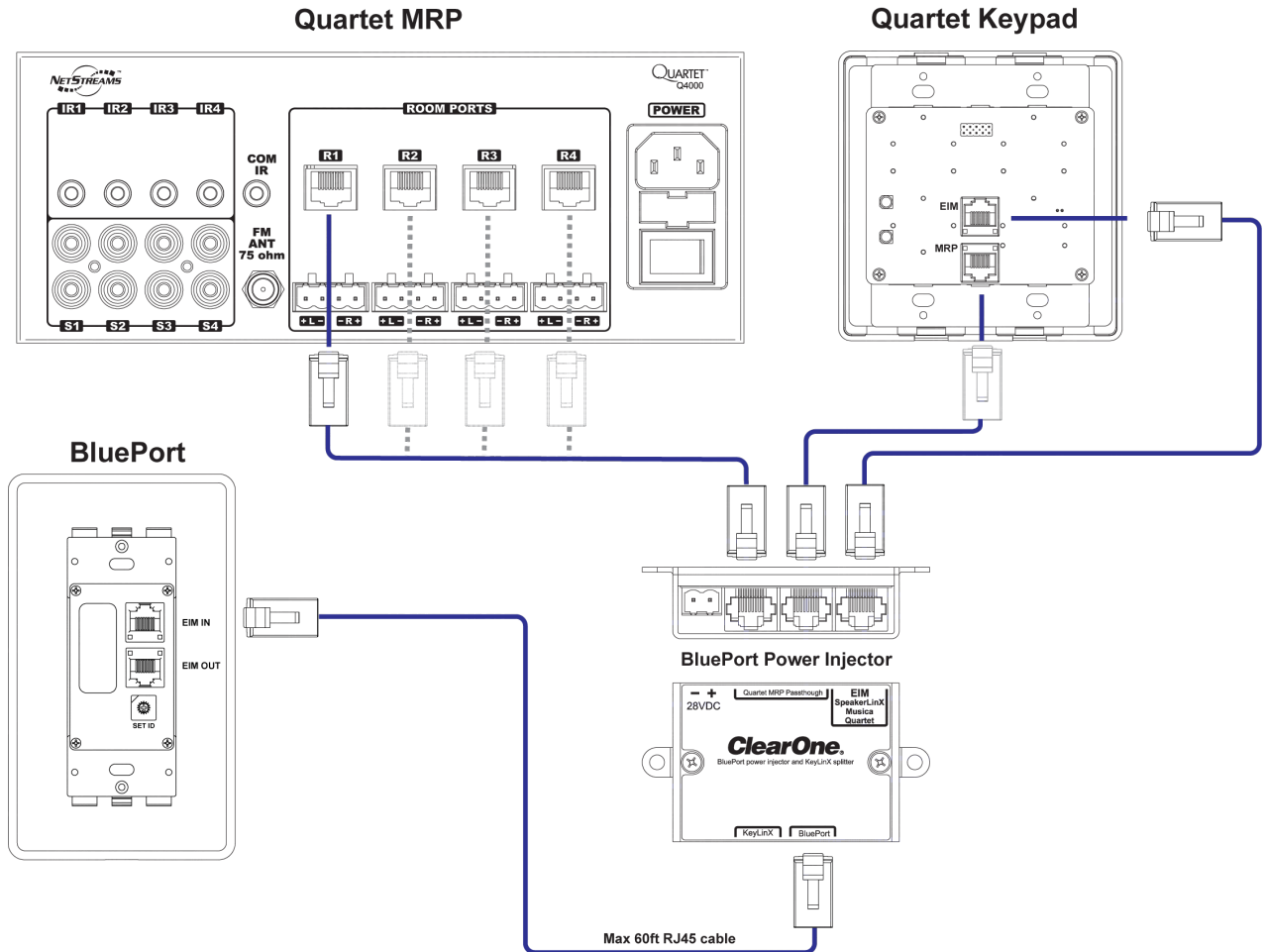

# Pairing the Wireless Device

## ZONE NAME SELECTOR SWITCH

Multiple BluePort NS-BP200 devices may be installed within wireless range of each other. In this case multiple “BluePort” names are listed on their wireless device when pairing. The Zone Name Selector rotating switch allows the installer to set one of sixteen (16) preset names for the BluePort. The switch needs to be set before using the BluePort.

Zone Selector Names			
Rotary Position	Zone Name	Rotary Position	Zone Name
0	BluePort	8	Study
1	Master	9	Outside
2	Bedroom	A	Lobby
3	Kitchen	B	Office
4	Dining Room	C	Foyer
5	Living Room	D	Board Room
6	Family Room	E	Lunch Room
7	Great Room	F	BluePort2

## HOW TO PAIR WITH THE BLUEPORT

1. Momentarily press the **Reset** button on the front of the BluePort to place the BluePort into pairing mode. The status LED will turn on solid while the BluePort is preparing for pairing mode. Once in pairing mode, the LED will start to blink. The BluePort will remain in pairing mode for five (5) minutes, or until a device connects.
2. Open the *Bluetooth* configuration page on your source device (Please refer to the *Bluetooth* instructions for your specific wireless device).
3. Enable *Bluetooth* on your source device, or start scanning for playback devices.
4. Look for the device identified by the preset name that has been selected on the BluePort using the “Set ID” rotary switch and pair with it.
5. If your device prompts you to enter a pairing code, enter “0000” (Four zeros).
6. Once paired and connected, the status light on the BluePort will turn off, unless your source device automatically starts streaming, in which case the LED will turn on for one (1) minute, or until the source device stops streaming.
7. Start streaming audio to the BluePort from your source device. The status LED on the BluePort will glow steady for one (1) minute when a new stream starts. On some wireless devices you may need to explicitly select *Bluetooth* as the audio output.

## RECONNECTING TO A PREVIOUSLY PAIRED BLUEPORT

The BluePort will store the previous sixteen (16) devices that have connected. Previously paired devices do not need to repeat pairing. Instead open the *Bluetooth* configuration page on your wireless source and reconnect to the room set with the Zone Name Selector rotary switch (SET ID). If a stream is playing from one device and second device connects and starts a stream, the second device's stream will be played. Connecting and starting a stream is a manual process; it does not automatically happen as a result of coming into proximity with a previously paired device.

## RESTORING TO FACTORY DEFAULTS

Restoring to factory defaults will remove all previous pairings. Any device previously paired will need to be re-paired for that device to work with the BluePort.

To restore the BluePort to its factory default condition, press and hold the **Reset** button for at least five (5) seconds. After five seconds the status LED will flutter, indicating that the BluePort is ready for a factory reset. Release the **Reset** button. The BluePort will reset and return to the factory defaults and is ready for use.

# Compliance and Service

## COMPLIANCE OVERVIEW

### RoHS Compliance

All components and processes used to produce the BluePort comply with the RoHS initiative.

### Electrical Safety Advisory

Any modifications to the device without express authorization from ClearOne is prohibited as per 47CFR15.21 and could void the users authority to operate the device.

FCC Part 15: This device complies with FCC Part 15 regulations for a Class B device.

### European Compliance

Details on European equipment compliance can be found on the ClearOne website at the following location: [www.ClearOne.com/resources/EuroDOC.php](http://www.ClearOne.com/resources/EuroDOC.php).

## SERVICE AND SUPPORT

If you need assistance setting up or operating your product, please contact us. We welcome your comments so we can continue to improve our products and better meet your needs.

### TECHNICAL SUPPORT

Telephone: 1.800.283.5936

E-mail: [tech.support@ClearOne.com](mailto:tech.support@ClearOne.com)

Web site: [www.ClearOne.com](http://www.ClearOne.com), [www.NetStreams.com](http://www.NetStreams.com)

### SALES

Telephone: 1.800.707.6994

E-mail: [sales@ClearOne.com](mailto:sales@ClearOne.com)

### TECHSALES

Telephone: 1.800.705.2103

E-mail: [techsales@ClearOne.com](mailto:techsales@ClearOne.com)

### PRODUCT RETURNS

All product returns require a Return Material Authorization (RMA) number. Contact ClearOne Technical Support before returning your product. Make sure you return all the items and packing materials that originally shipped with your product.

## > CLEARONE LOCATIONS

### HEADQUARTERS:

#### Salt Lake City, UT USA

5225 Wiley Post Way  
Suite 500  
Salt Lake City, UT 84116

Tel: 801.975.7200

Toll Free: 800.945.7730

Fax: 801.977.0087

e-mail: [sales@clearone.com](mailto:sales@clearone.com)

#### EMEA

Tel: 44 (0) 1189.036.053

e-mail: [global@clearone.com](mailto:global@clearone.com)

#### APAC

Tel: 801.303.3388

e-mail: [global@clearone.com](mailto:global@clearone.com)

#### LATAM

Tel: 801.974.3621

e-mail: [global@clearone.com](mailto:global@clearone.com)

#### TechSales

Tel: 800.705.2103

e-mail: [techsales@clearone.com](mailto:techsales@clearone.com)

#### Technical Support

Tel: 800.283.5936

e-mail: [tech.support@clearone.com](mailto:tech.support@clearone.com)