



## CH-1109TXC & RXC

HDMI to CAT5e/CAT6 with LAN/PoE/IR Extender



Operation Manual



## **DISCLAIMERS**

The information in this manual has been carefully checked and is believed to be accurate. Cypress Technology assumes no responsibility for any infringements of patents or other rights of third parties which may result from its use.

Cypress Technology assumes no responsibility for any inaccuracies that may be contained in this document. Cypress also makes no commitment to update or to keep current the information contained in this document.

Cypress Technology reserves the right to make improvements to this document and/or product at any time and without notice.

## **COPYRIGHT NOTICE**

No part of this document may be reproduced, transmitted, transcribed, stored in a retrieval system, or any of its part translated into any language or computer file, in any form or by any means—electronic, mechanical, magnetic, optical, chemical, manual, or otherwise—without express written permission and consent from Cypress Technology.

© Copyright 2011 by Cypress Technology.

All Rights Reserved.

Version 1.1 August 2011

## **TRADEMARK ACKNOWLEDGMENTS**

All products or service names mentioned in this document may be trademarks of the companies with which they are associated.





## PRECAUTIONS

Please read all instructions before attempting to unpack, install or operate this equipment and before connecting the power supply.

Please keep the following in mind as you unpack and install this equipment:

- Always follow basic safety precautions to reduce the risk of fire, electrical shock and injury to persons.
- To prevent fire or shock hazard, do not expose the unit to rain, moisture or install this product near water.
- Never spill liquid of any kind on or into this product.
- Never push an object of any kind into this product through any openings or empty slots in the unit, as you may damage parts inside the unit.
- Do not attach the power supply cabling to building surfaces.
- Use only the supplied power supply unit (PSU). Do not use the PSU if it is damaged.
- Do not allow anything to rest on the power cabling or allow any weight to be placed upon it or any person walk on it.
- To protect the unit from overheating, do not block any vents or openings in the unit housing that provide ventilation and allow for sufficient space for air to circulate around the unit.

## REVISION HISTORY

VERSION NO.	DATE DD/MM/YY	SUMMARY OF CHANGE
VS1	25/11/11	First release



# CONTENTS

- 1. Introduction..... 1**
- 2. Applications..... 1**
- 3. Package Contents ..... 1**
- 4. System Requirements..... 1**
- 5. Features ..... 2**
- 6. Operation Controls and Functions..... 3**
  - 6.1 Transmitter ..... 3
  - 6.2 Receiver ..... 4
  - 6.3 D-Sub 9 Pin Definitions ..... 5
- 7. Connection Diagram ..... 6**
- 8. Specifications ..... 7**
- 9. Acronyms ..... 8**



## 1. INTRODUCTION

The device that can make your home or office more efficient, the CH-1109TXC & RXC is capable of sending HDMI (uncompressed audio/video), 3 Ethernet connections and control ports (through the built-in RS-232 and IR ports) over a single CAT5e/CAT6 up to a distance of 100m (300 ft.). Even more, it is adaptor free at the receiver end.

Further, with the HDMI bypass is designed to allow instant display at the control point. So, if you wish to make your home or office more efficient, get the HDMI over Single CAT5e/CAT6 with LAN/PoE & IR Extender and prepare to be amazed.

## 2. APPLICATIONS

- Household entertainment media sharing and control
- Lecture room display and control
- Showroom display and control
- Meeting room presentation and control
- Classroom display and control
- Any Smart AV Installation system

## 3. PACKAGE CONTENTS

- HDMI to CAT5e/CAT6 with LAN/PoE/IR Transmitter
- CAT5e/CAT6 to HDMI with LAN/PoE/IR Receiver
- 1× IR Blaster
- 1× IR Receiver
- 24V DC Power Adaptor
- Operation Manual

## 4. SYSTEM REQUIREMENTS

- Input HDMI source equipment such as DVD/Blu-ray player and output display with HDMI input.
- RS232 controlled device
- Ethernet equipped device

## 5. FEATURES

- HDMI 1.4 compliant with 3D formats and 4k/2k resolution support
- Supports CEC bypass function
- Simultaneous transmission of uncompressed video and audio (1080p@60Hz/-Deep Color) over a single CAT5e/CAT6 type cable for up to 100m (300ft.).  
*NOTE: Tested with CAT-6E/23AWG cables, using cables of another specification may result in a different operating distance.*
- Audio support up to 7.1CH Dolby TrueHD and DTS-HD
- Connect and share up to 6 Ethernet connections at speeds up to 100Mbps
- Various controls over HDMI: CEC, RS232 and IR
- 5Play™ convergence: HD video, audio & Control ports (IR and RS232)/LAN/PoE
- Installation friendly
- Single power supply powers both units, receiver unit is powered through the transmitter.

## 6. OPERATION CONTROLS AND FUNCTIONS

### 6.1 Transmitter

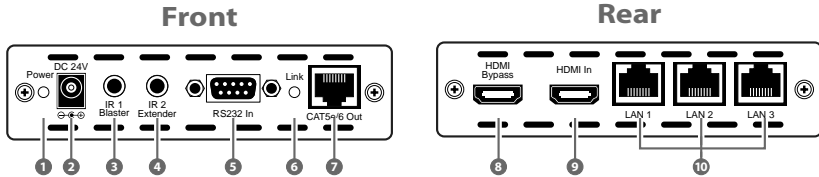

#### 1 Power LED

The red LED will illuminate when the 24V DC Adaptor is connected to the AC outlet.

#### 2 DC 24V

This slot is where you plug the 24V DC power supply into the unit and connect the adaptor to an AC outlet.

#### 3 IR 1 Blaster

Connect the IR blaster cables included in the package for IR signal transmission. The related IR receiver port is IR1 Extender.

#### 4 IR 2 Extender

Connect the IR receiver cables included in the package for IR signal reception. The related IR transmitter port is IR2 Blaster.

#### 5 RS-232 In

This slot is to connect with PC/laptop with D-Sub 9-pin male cable for sending RS-232 commands.

#### 6 Link LED

This yellow LED will illuminate when the both CAT5e/6 input and output signal is connected.

#### 7 CAT5e/6 Out

Connect the transmitter and receiver via a single CAT5e/6 type cable for all data transmission.

#### 8 HDMI Bypass

Connect to a HDMI TV/monitor for instant display of the HDMI input source signal.



NOTE: When the HDMI bypass is connected, no signals will be transmitted to the receiver side. Therefore, unplug this connection after confirming that the correct image is displayed

## 9 HDMI In

Connect to the HDMI equipped source equipment such as DVD or Blu-ray player.

## 10 LAN 1/2/3

The LAN connections can be used to connect and share up to 6 ethernet connections (3 at the receiver end, 3 at the transmitter end), including computers, routers and media servers.

## 6.2 Receiver

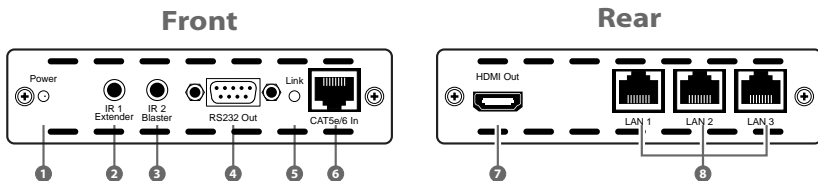

### 1 Power LED

The red LED will illuminate when the 24V DC Adaptor is connected to the AC outlet.

### 2 IR 1 Extender

This slot is to connect with the IR receiver cables included in the package for IR signal reception. The related IR transmitter port is IR1 Blaster.

### 3 IR 2 Blaster

Connect the IR blaster cables included in the package for IR signal transmission. The related IR receiver port is IR2 Extender.

### 4 RS-232 Out

Connect to a device that can be controlled (via D-Sub 9-pin female cable) by RS-232 commands.

### 5 Link LED

This yellow LED will illuminate when the both CAT5e/6 input and output signal is connected.

## 6 CAT5e/6 IN

Connect the transmitter and receiver via a single CAT5e/6 type cable for all data transmission.

## 7 HDMI Out

Connect to a HDMI equipped TV or monitor to display the HDMI input source signal.

## 8 LAN 1/2/3

The LAN connections can be used to connect and share up to 6 ethernet connections (3 at the reciver end, 3 at the transmitter end), including computers, routers and media servers.

### 6.3 D-Sub 9 Pin Definitions

Pin	Define TX/RX
1	N/C
2	TxD / RxD
3	RxD / TxD
4	N/C
5	GND
6	N/C
7	N/C
8	N/C
9	N/C

# 7. CONNECTION DIAGRAM

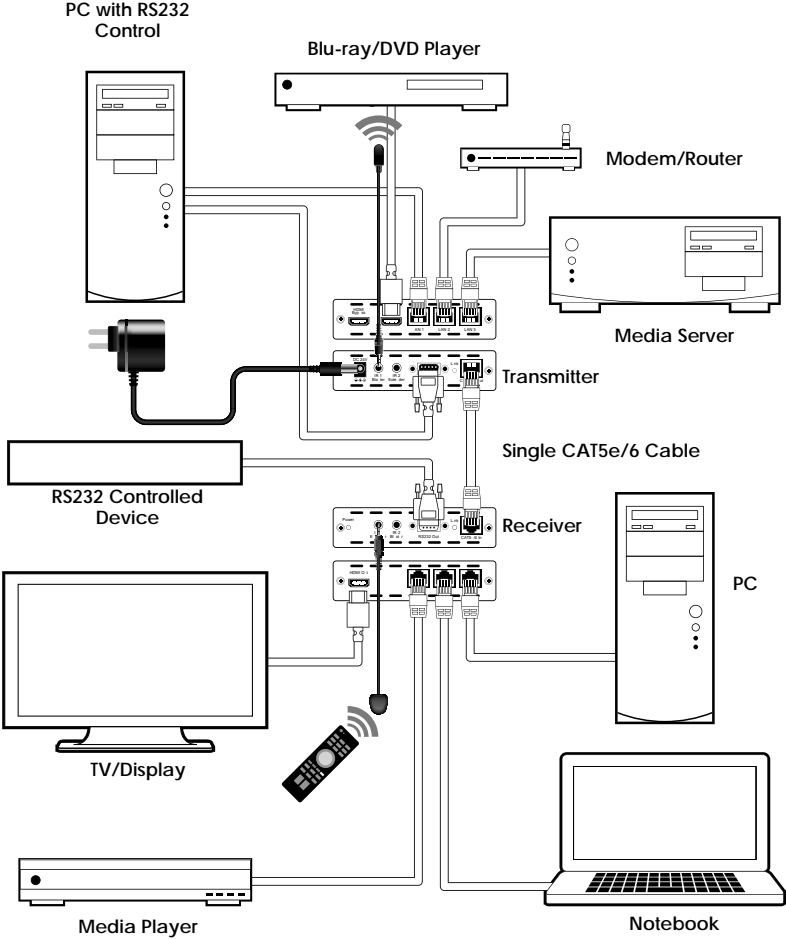



## 8. SPECIFICATIONS

<b>Maximum Data Rate</b>	10.2 Gbps
<b>Resolution Range</b>	Deep Color
<b>Ethernet Speed</b>	100 Mbps
<b>Transmitter</b>	
<b>Input</b>	1 × HDMI , 3 × Ethernet, 1 × RS-232, 1 × IR Extender
<b>Output</b>	1 × CAT5e/6, 1 × HDMI Bypass, 1 × IR Blaster
<b>Receiver</b>	
<b>Input</b>	1 × CAT5e/6, 1 × IR Extender
<b>Output</b>	1 × HDMI, 1 × RS-232, 3 × Ethernet, 1 × IR Blaster
<b>ESD Protection</b>	Human Body Model: ±8kV (air-gap discharge) ±4kV (contact discharge)
<b>IR Frequency Rate</b>	30~50 kHz
<b>Power Supply</b>	24 V/1.25 A DC (US/EU Standards, CE/FCC/ UL certified)
<b>Dimensions</b>	125 mm(W) x 127 mm (D) x 30 mm (H) Each
<b>Weight</b>	Tx: 360g, Rx: 382g
<b>Chassis Material</b>	Aluminum
<b>Silkscreen Color</b>	Black
<b>Power Consumption</b>	Tx: 6 W: Rx: 8 W
<b>Operating Temperature</b>	0°C ~ 40°C / 32°F ~ 104°F
<b>Storage Temperature</b>	-20 °C ~ 60 °C / -4°F ~ 140 °F
<b>Relative Humidity</b>	20~90% RH (non-condensing)

## 9. ACRONYMS

ACRONYM	COMPLETE TERM
CAT6	Category 6 Cable
HDMI	High Definition Multimedia Interface



NOTES:





**CYPRESS TECHNOLOGY CO., LTD**  
Home page: <http://www.cypress.com.tw>