



COH-TX1 & COH-RX1

HDMI to Optical Transmitter and Receiver



Operation Manual

DISCLAIMERS

The information in this manual has been carefully checked and is believed to be accurate. Cypress Technology assumes no responsibility for any infringements of patents or other rights of third parties which may result from its use.

Cypress Technology assumes no responsibility for any inaccuracies that may be contained in this document. Cypress also makes no commitment to update or to keep current the information contained in this document.

Cypress Technology reserves the right to make improvements to this document and/or product at any time and without notice.

COPYRIGHT NOTICE

No part of this document may be reproduced, transmitted, transcribed, stored in a retrieval system, or any of its part translated into any language or computer file, in any form or by any means—electronic, mechanical, magnetic, optical, chemical, manual, or otherwise—without express written permission and consent from Cypress Technology.

© Copyright 2011 by Cypress Technology.

All Rights Reserved.

Version 1.1 August 2011

TRADEMARK ACKNOWLEDGMENTS

All products or service names mentioned in this document may be trademarks of the companies with which they are associated.





SAFETY PRECAUTIONS

Please read all instructions before attempting to unpack, install or operate this equipment and before connecting the power supply.

Please keep the following in mind as you unpack and install this equipment:

- Always follow basic safety precautions to reduce the risk of fire, electrical shock and injury to persons.
- To prevent fire or shock hazard, do not expose the unit to rain, moisture or install this product near water.
- Never spill liquid of any kind on or into this product.
- Never push an object of any kind into this product through any openings or empty slots in the unit, as you may damage parts inside the unit.
- Do not attach the power supply cabling to building surfaces.
- Use only the supplied power supply unit (PSU). Do not use the PSU if it is damaged.
- Do not allow anything to rest on the power cabling or allow any weight to be placed upon it or any person walk on it.
- To protect the unit from overheating, do not block any vents or openings in the unit housing that provide ventilation and allow for sufficient space for air to circulate around the unit.

REVISION HISTORY

VERSION NO.	DATE DD/MM/YY	SUMMARY OF CHANGE
VS1	20/03/12	First Release



CONTENTS

1. Introduction	1
2. Applications	1
3. Package Contents	1
4. System Requirements	1
5. Features	2
6. Operation Controls and Functions	3
6.1 Transmitter Front and Rear Panels..	3
6.2 Receiver Front and Rear Panels	4
7. Support Timing Chart	5
7.1 TV Timing	5
7.2 PC Timing	6
8. Connection Diagram	7
9. Specifications	8
10. Acronyms	9





1. INTRODUCTION

With HDMI becoming more and more popular around the world, many consumers have been searching for a way to transmit HDMI signals over very long distances. The HDMI to Optical Transmitter and Receiver set which uses fiber optical cables will give you longer transmission distances (up to 300m) while also providing you with thinner, lighter cables for easier installation. With this system the HDMI signal is not compressed and is fully compliant with HDMI and HDCP.

2. APPLICATIONS

- IR & RS-232 control over fiber optical
- Digital signage, airport displays, advertising, video walls or special events
- Surveillance systems

3. PACKAGE CONTENTS

- HDMI to Optical Transmitter
- Optical to HDMI Receiver
- 2 x 3.5mm phone jack to D-Sub 9pin converter cables
- 1 x IR Extender
- 1 x IR Blaster
- 2 x 5V DC Power Adaptors
- Operation Manual

4. SYSTEM REQUIREMENTS

Input source devices such as DVD or Blu-Ray players with HDMI cables and output displays such as HDTV's and monitors with HDMI ports.

5. FEATURES

- HDMI v1.2, HDCP and DVI compliance
- Long transmission distances - up to 300m or more
- Thinner and lighter cables for easier, more discreet installations
- Faster data transmission
- Lower power consumption
- Support the reading of EDID information



6. OPERATION CONTROLS AND FUNCTIONS

6.1 Transmitter Front and Rear Panels

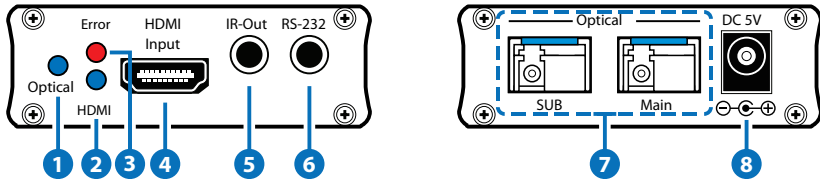

- 1 OPTICAL LED:** This blue LED will illuminate when at least one optical cable is connected and has successfully detected and communicated data between the Transmitter and Receiver.
Note: If the LED is not illuminated then users will need to check the connection of the fiber cable between the Transmitter and Receiver units and then check the connection is good and that the cable itself is correct and undamaged.
- 2 ERROR LED:** This red LED will illuminate when there is an error in the input signal data rate that is higher than 75/170MHz (Single/Dual). Double Check all connections and make sure they are properly connected.
- 3 HDMI LED:** This blue LED will illuminate when the Transmitter unit is receiving a HDMI signal from the source device.
- 4 HDMI INPUT:** Connect to an HDMI input source such as a DVD or Blu-ray player with a HDMI cable.
- 5 IR-OUT:** Connect to the supplied IR blaster cable for IR signal transmission. Place the IR blaster in direct line-of-sight of the equipment to be controlled.
- 6 RS-232:** Connect to a PC or laptop (with supplied 3.5mm phone jack to D-Sub 9pin adaptor) for the transmission of RS-232 commands.
- 7 OPTICAL SUB & MAIN:** Connect the Transmitter and Receiver units with 2-way fiber optical cable to transmit the data signal
Note: Connector Type: LC-LC, Fiber: Duplex Single-mode Fiber
- 8 DC 5V:** Connect to the power adaptor included in the package from the AC wall outlet for power supply.

6.2 Receiver Front and Rear Panels

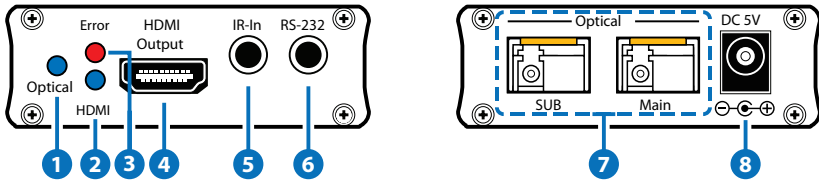

- 1 OPTICAL LED:** This blue LED will illuminate when at least one optical cable is connected and has successfully detected and communicated data between the Transmitter and Receiver.
Note: If the LED is not illuminated then users will need to check the connection of the fiber cable between the Transmitter and Receiver units and then check the connection is good and that the cable itself is correct and undamaged.
- 2 HDMI LED:** This blue LED will illuminate when the device is successfully communicating with the display.
- 3 ERROR LED:** Under normal conditions, this red LED will not illuminate but will blink for few seconds when startup of the device. When the LED is illuminated constantly, it means the HDMI output is not able to output a HDMI signal. Double check the connection and also make ensure the source is sending a compatible HDMI signal. Check all connections and make sure they are all properly connected.
- 4 HDMI OUTPUT:** Connect to a HDMI Display device, such as a TV or monitor, with a HDMI cable.
- 5 IR-IN:** Connect to the supplied IR Extender cables for IR signal reception. Ensure that remote being used is within the direct line-of-sight of the IR extender.
- 6 RS-232:** Connect to the device that is to be controlled (with the supplied 3.5mm phone jack to D-Sub 9pin adaptor) by RS-232 commands
- 7 OPTICAL SUB & MAIN:** Connect the Transmitter and Receiver units with 2-way fiber optical cable to transmit the data signal.
Note: Connector Type: LC-LC, Fiber: Duplex Single-mode Fiber
- 8 DC 5V:** Connect to the power adaptor included in the package from the AC wall outlet for power supply.



7. SUPPORT TIMING CHART

7.1 TV Timing

VIC	Formats	Field Rate	Picture Aspect Ratio
1	720 × 480p	59.94Hz/60Hz	4:3
2	720 × 480p	59.94Hz/60Hz	16:9
3	1280 × 720p	59.94Hz/60Hz	16:9
4	1920 × 1080i	59.94Hz/60Hz	16:9
5	720 (1440) × 480i	59.94Hz/60Hz	4:3
6	720 (1440) × 480i	59.94Hz/60Hz	16:9
7	1920 × 1080p	59.94Hz/60Hz	16:9
8	720 × 576p	50Hz	4:3
9	720 × 576p	50Hz	16:9
10	1280 × 720p	50Hz	16:9
11	1920 × 1080i	50Hz	16:9
12	720 (1440) × 576i	50Hz	4:3
13	720 (1440) × 576i	50Hz	16:9
14	1920 × 1080p	50Hz	16:9
15	1920 × 1080p	23.97Hz/24Hz	16:9
16	1920 × 1080p	25Hz	16:9
17	1920 × 1080p	29.97Hz/30Hz	16:9

7.2 PC Timing

Pixel Format	Refresh Rate	Horizontal Frequency	Pixel Frequency	Standard Type
640×350	85 Hz	37.9 kHz	31.500 MHz	VESA Standard
640×400	85 Hz	37.9 kHz	31.500 MHz	VESA Standard
720×400	85 Hz	37.9 kHz	35.500 MHz	VESA Standard
640×480	60 Hz	31.5 kHz	25.175 MHz	Industry Standard
800×600	60 Hz	37.9 kHz	40.000 MHz	VESA Guidelines
1024×768	60 Hz	48.4 kHz	65.000 MHz	VESA Guidelines
1280×720	60 Hz	45.0 kHz	74.250 MHz	CEA Standard
1280×768	60 Hz	47.8 kHz	79.500 MHz	CVT
1280×960	60 Hz	60.0 kHz	108.000 MHz	VESA Standard
1280×1024	60 Hz	64.0 kHz	108.000 MHz	VESA Standard
1366×768	60 Hz (RB)	47.4 kHz	85.500 MHz	VESA Standard
1400×1050	60 Hz	65.3 kHz	121.750 MHz	CVT
1440×900	60 Hz	55.9 kHz	106.500 MHz	CVT
1680×1050	60 Hz(RB)	64.7 kHz	119.000 MHz	CVT Red. Blanking
1920×1080	60 Hz	67.5 kHz	148.500 MHz	CEA Standard
1920×1200	60 Hz(RB)	74.0 kHz	154.000 MHz	CVT Red. Blanking

8. CONNECTION DIAGRAM

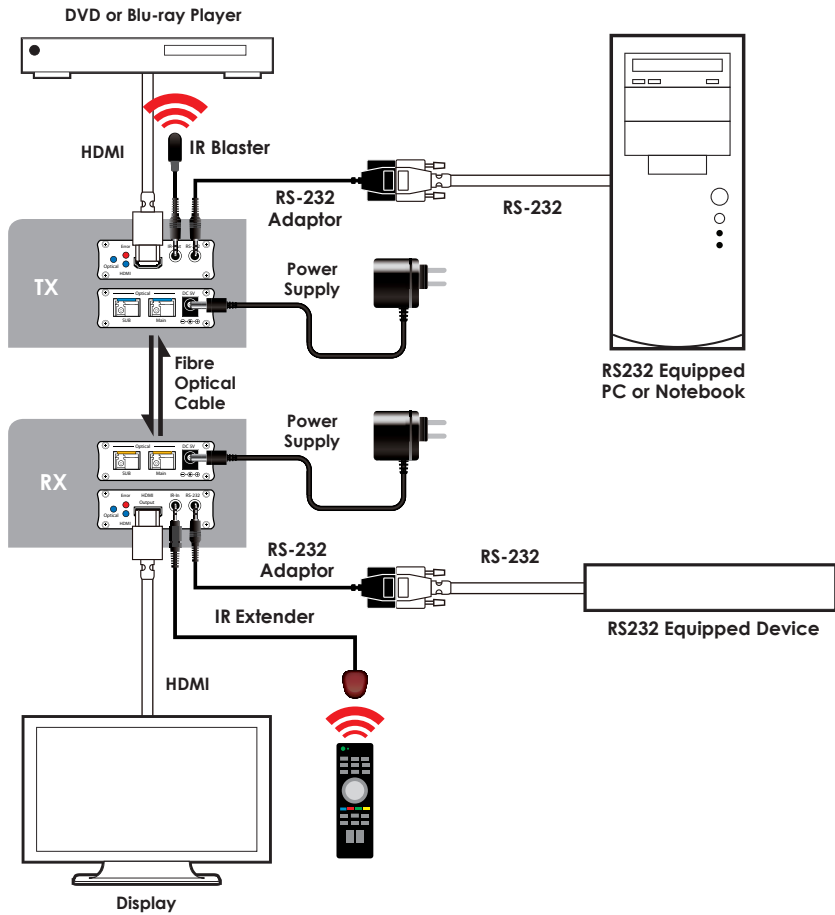

Note: The RS-232 design here works in 2 ways and therefore, no Input/Output determination.

9. SPECIFICATIONS

Optical Fiber Transmitter	Duplex SM 9/125um, LC-LC Connector
Input Port	1 × HDMI, 1 × RS-232, 1 × IR Out
Output Port	1 × Duplex Single-mode Fiber Optical
Receiver	
Input Port	1 × Duplex Single-Mode Fiber Optical
Output Port	1 × HDMI, 1 × RS-232, 1 × I R In
HDMI In/Out Cable	Up to 10 Meters
Distance	
Optical In/Out Cable	Up to 300 Meters
Distance	
ESD Protection	Human Body Model: ±8kV (air-gap discharge) ±4kV (contact discharge)
Power Supply	5V/1.25A DC (US/EU Standards, CE/ FCC/UL certified)
Dimensions	114 mm (W)×65 mm (D)× 26 mm (H)/ Each
Weight	200 g/Each
Chassis Material	Metal
Silkscreen Color	Black
Operating Temperature	0 °C~40 °C/32 °F~104 °F
Storage Temperature	-20 °C~60 °C/-4 °F~140 °F
Relative Humidity	20~90% RH (non-condensing)
Power Consumption	4.6W (TX), 4W (RX)



10. ACRONYMS

ACRONYM	COMPLETE TERM
HDCP	High-bandwidth Digital Content Protection
HDMI	High Definition Multimedia Interface



CYPRESS TECHNOLOGY CO., LTD

Home page: <http://www.cypress.com.tw>