



DCT-21

HD Audio Center



Operation Manual



DISCLAIMERS

The information in this manual has been carefully checked and is believed to be accurate. Cypress Technology assumes no responsibility for any infringements of patents or other rights of third parties which may result from its use.

Cypress Technology assumes no responsibility for any inaccuracies that may be contained in this document. Cypress also makes no commitment to update or to keep current the information contained in this document.

Cypress Technology reserves the right to make improvements to this document and/or product at any time and without notice.

COPYRIGHT NOTICE

No part of this document may be reproduced, transmitted, transcribed, stored in a retrieval system, or any of its part translated into any language or computer file, in any form or by any means—electronic, mechanical, magnetic, optical, chemical, manual, or otherwise—without express written permission and consent from Cypress Technology.

© Copyright 2011 by Cypress Technology.

All Rights Reserved.

Version 1.1 August 2011

TRADEMARK ACKNOWLEDGMENTS

All products or service names mentioned in this document may be trademarks of the companies with which they are associated.



SAFETY PRECAUTIONS

Please read all instructions before attempting to unpack, install or operate this equipment and before connecting the power supply.

Please keep the following in mind as you unpack and install this equipment:

- Always follow basic safety precautions to reduce the risk of fire, electrical shock and injury to persons.
- To prevent fire or shock hazard, do not expose the unit to rain, moisture or install this product near water.
- Never spill liquid of any kind on or into this product.
- Never push an object of any kind into this product through any openings or empty slots in the unit, as you may damage parts inside the unit.
- Do not attach the power supply cabling to building surfaces.
- Use only the supplied power supply unit (PSU). Do not use the PSU if it is damaged.
- Do not allow anything to rest on the power cabling or allow any weight to be placed upon it or any person walk on it.
- To protect the unit from overheating, do not block any vents or openings in the unit housing that provide ventilation and allow for sufficient space for air to circulate around the unit.

REVISION HISTORY

| VERSION NO. | DATE DD/MM/YY | SUMMARY OF CHANGE |
|-------------|---------------|-------------------------|
| RDV1 | 01/07/11 | Preliminary Release |
| RDV2 | 16/01/12 | |
| VS0 | 13/08/12 | Updated format/diagrams |
| RDV3 | 17/08/12 | OLED Menu |
| VS0 | 21/11/12 | Revised features list |
| RDV4 | 22/06/15 | Add Audio Spec. |





CONTENTS

| | |
|--|-----------|
| 1. Introduction | 1 |
| 2. Applications | 1 |
| 3. Package Contents | 1 |
| 4. System Requirements | 2 |
| 5. Features | 2 |
| 6. Operation Controls and Functions | 4 |
| 6.1 Front Panel | 4 |
| 6.2 Rear Panel | 5 |
| 6.3 Top Panel | 6 |
| 6.4 Remote Control | 6 |
| 6.5 OLED Menu | 7 |
| 7. Connection Diagram | 8 |
| 8. Specifications | 9 |
| 9. Acronyms | 11 |



1. INTRODUCTION

The HD Audio Center is designed to allow multiple audio sources to be controlled, switched and output to a variety of audio equipment. With its 6 audio inputs (including an HDMI input) and 6 audio outputs (including a 6.3mm headphone output) you can integrate and convert any digital or analog audio source to any type of amplifier or active speakers.

This device has an built-in sampling rate converter which can upscale audio signals between 44.1 kHz to 192 kHz (24-bit). With HDMI connectivity, it allows the user to embed or de-embed audio within the HDMI signal path.

For professionals, the headphone amplifier, XLR (Low-noise Professional Balanced output) and 6.3mm headphone jack (3.5 mini-jack adaptor supplied) offer unparalleled audio quality. With a highly accurate PLL and low jitter reduction clock system, and with an OLED display and IR remote for controlling the device the HD Audio Center is an incredibly useful tool for getting the most out of your audio devices.

2. APPLICATIONS

- Multiple input/output Audio Center
- Audio format and sampling rate conversion
- Professional audio system integration with XLR balanced outputs
- Mac/PC USB audio output support
- Analog to digital or digital to analog audio conversion
- HDMI audio embedding or de-embedding

3. PACKAGE CONTENTS

- 1×HD Audio Center
- 1×Remote Control (with battery)
- 1×6.3mm to 3.5mm Headphone Adaptor
- 1×Software CD
- 1×5 V/3 A DC Power Adaptor
- Operation Manual



4. SYSTEM REQUIREMENTS

Input source equipment such as PC (USB) or DVD player with relevant connection cables and output to amplifier, active speakers or headphones

5. FEATURES

Main

- 6 Input, 6 Output HD Audio Center
- 4 Digital Inputs, 2 Analog Inputs
- 3 Digital Outputs, 2 Analog Outputs and Headphone Output
- Full system control from IR remote or main control dial via OLED display.

Digital

- HDMI, USB, Optical and Coaxial digital audio inputs support LPCM stereo
- HDMI input supports LPCM stereo in all modes but can pass surround sound signal whilst in bypass mode
- All digital inputs support 192kHz sampling rate at up to 24-bit resolution
- HDMI, Optical and Coaxial digital outputs
- All digital inputs can be SRC (Sample Rate Conversion) to 44.1, 48, 88.2, 96, 176.4 and 192 kHz via DSP Engine (Digital Signal Processing)
- Highly accurate PLL and low jitter reduction clock system
- HDMI Audio output (video is always bypassed to HDMI output) can either output the incoming HDMI (HDMI Bypass Mode) or embed the selected audio signal (HDMI Input Mode)

Analog

- Built-in Ti TPA6120A2 high quality headphone amplifier output
- Professional XLR balanced stereo output
- RCA analog stereo output
- RCA analog stereo input
- Mini-jack (3.5mm) stereo input
- Total Harmonic Distortion (THD): Less than 100dB (-20dBFS)
- Analog inputs provide digital output sampling rates up to 192 kHz

Misc

- IR Remote with direct source, power and mute buttons
- HDMI audio embedding or de-embedding
- Volume control of analog and headphone outputs or just headphone output via remote or main control dial
- Direct power and mute button on unit
- High viewing angle OLED display
- Headphone output fades in after system is muted
- 6.3mm headphone output (3.5mm mini-jack adaptor supplied)

6. OPERATION CONTROLS AND FUNCTIONS

6.1 Front Panel

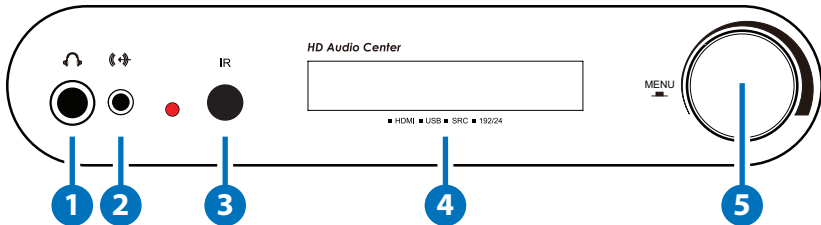

- 1 **6.3mm Headphone Output:** Connect to 6.3mm professional headphone set for user to enjoy the individual professional audio sound.
- 2 **3.5mm Line-level Input:** Connect 3.5mm mini-jack cable to any audio equipment for stereo input audio signal.
- 3 **IR:** IR receiver window. Accepts the IR signal from the supplied remote control.
- 4 **OLED:** Displays the input/output selection, volume setting, sampling rate and audio channels.

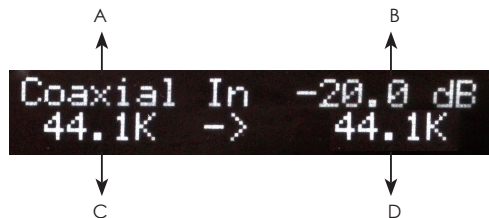

- A. Input source
- B. Headphone or analog line level volume or system mute
- C. Input sampling rate
- D. Output sampling rate

- 5 **MENU/VOLUME Controller:** Turn to adjust the volume. Press inwards to enter into the menu and turn it to select the desire setting, press again to confirm the selection.

Note: The Volume and Mute functions only affect the headphone and analog line-out volume levels, all other outputs are not affected.

6.2 Rear Panel

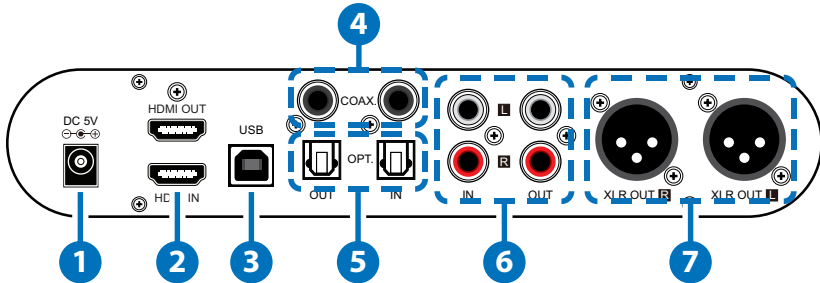

- 1 DC 5V:** Plug the 5V DC power supply into the unit and connect the adaptor to an AC outlet.
- 2 HDMI IN/OUT:** Connect to an HDMI source such as a satellite box or DVD Audio player and output to an HDMI HDTV/AV Receiver for display output.
- 3 USB:** Connect to a PC/MAC source for USB audio signal input.
- 4 COAX OUT/IN:** Connect the COAX IN to a coaxial digital audio input source such as set-top box or CD player and the COAX OUT to an amplifier or active speakers with a coaxial cable.
- 5 OPT. OUT/IN:** Connect the OPT. IN to an optical digital audio input source such as a DVD/CD player or PS3 and the OPT. OUT to an amplifier or active speakers with an optical cable.
- 6 L/R IN/OUT:** Connect the L/R IN to an analog stereo input source such as a CD player or media player and the L/R OUT to amplifier or active speakers with RCA jack cables.
- 7 XLR L/R OUT:** Connect to an amplifier with balanced XLR inputs or directly to professional balanced equipment with XLR cables.

Note:

HDMI Input Mode: In this mode, whatever audio input is selected will be routed to the HDMI output as well as all other outputs.

HDMI Bypass Mode: In this mode HDMI video and audio will always be routed to the HDMI output no matter what input is selected, whilst all other outputs will output the audio from the selected input. This function allows the user to have two distinct audio pathways through the unit.

6.3 Top Panel

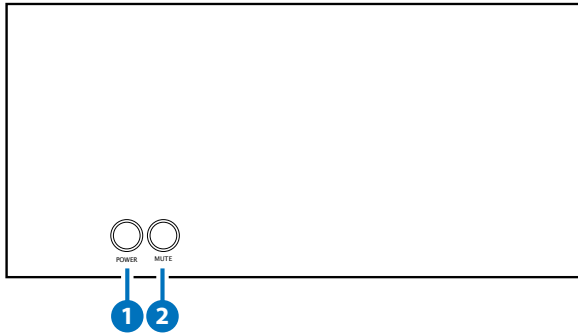

- 1 POWER:** Press this button to switch on the device or set to standby mode.
- 2 MUTE:** Press this button to mute or unmute the audio volume instantly.

6.4 Remote Control

- 1 POWER:** Press the button to turn On or to set the device to standby mode.
- 2 MUTE:** Press the button to mute or unmute the audio volume instantly.
- 3 VOL:** Press these buttons to turn up or down on the output audio volume.
- 4 MENU:** Press the button to enter into the menu selections then press the volume up/down buttons to select and press it again to confirm the selection.
- 5 RETURN:** Press the button to return or exit the menu selection.
- 6 INPUT:** Press these hot keys to switch the input sources instantly.

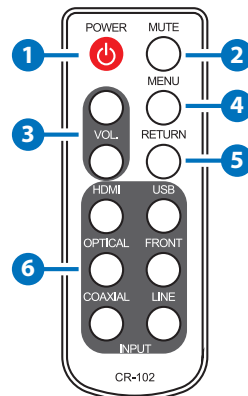

6.5 OLED Menu

| 1ST LAYER | FULL NAME | 2ND LAYER |
|-------------------------|--------------------------------|------------------|
| Source In | Source Selection | HDMI In |
| | | USB In |
| | | Optical In |
| | | Coaxial In |
| | | Line In (L/R In) |
| | | Front In |
| | | Return |
| SRC Set | Sampling Rate Conversion Setup | Bypass |
| | | 192 kHz |
| | | 176.4 kHz |
| | | 96 kHz |
| | | 88.2 kHz |
| | | 48 kHz |
| | | 44.1 kHz |
| Return | | |
| HDMI TX Set | HDMI Output Setup | Bypass |
| | | Input |
| | | Return |
| Display Set | Display Time Out Setup | TimeOut 5s |
| | | TimeOut 10s |
| | | TimeOut 15s |
| | | Return |
| HP Impedance | Headphone Impedance | 16 Ω |
| | | 32 Ω |
| | | 64 Ω |
| | | 200 Ω |
| | | 300 Ω |
| | | 600 Ω |
| | | Return |
| Line Out Set | Headphone/Line Out Setup | Fix Level |
| | | Volume Level |
| | | Return |
| Reset to Default | | OK |
| | | Return |
| Return | | |

7. CONNECTION DIAGRAM

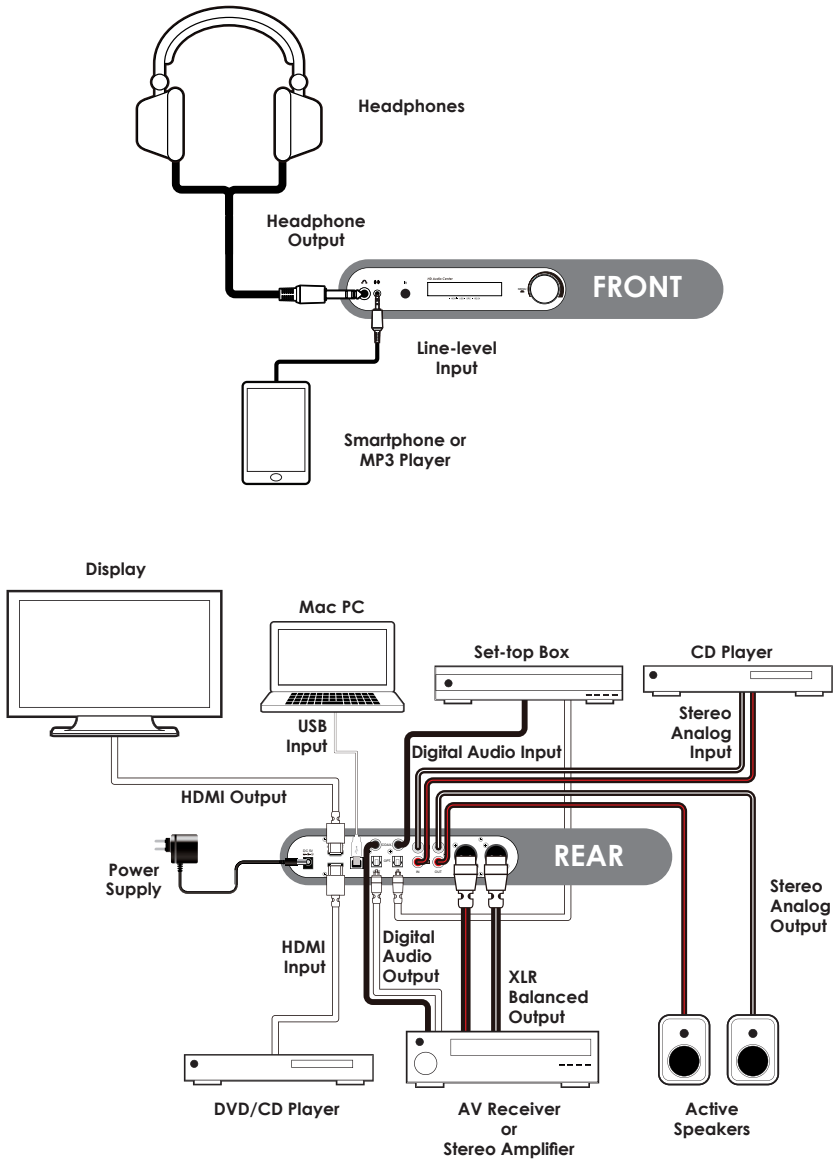

8. SPECIFICATIONS

| | |
|----------------------------------|---|
| Input Ports | 1×HDMI, 1×USB (Type B), 1×Coaxial, 1×Optical, 1×L/R (Analog Stereo 2RCA), 1×3.5mm Phone Jack (L/R) |
| Output Ports | 1×HDMI, 1×Coaxial, 1×Optical, 1×L/R (Analog Stereo 2RCA), 1×XLR (Balanced Analog Stereo), 1×6.3mm Phone Jack (Headphone) |
| Digital Audio I/O Support | LPCM 2CH |
| Stereo Audio I/O Level | 2 Vrms ±0.2 |
| XLR Blanced I/O Level | 4 Vrms ±0.2 |
| Headphone Impedance | 16 Ω ~ 600 Ω |
| ESD Protection | Human body model: ±8kV (air-gap discharge) ±6kV(contact discharge) |
| Power Supply | 5V/3A DC (US/EU standards, CE/FCC/ UL certified) |
| Dimensions | 138mm (W)×223mm (D)×50mm (H) |
| Weight | 680g |
| Chassis Material | Aluminum |
| Silkscreen Color | Black |
| Power Consumption | 15W |



Audio Specifications:

| IN \ OUT | OUTPUT | OUTPUT LEVEL | T.H.D+N (A-WEIGHT) | FREQUENCY RESPONSE | SNR | CROSSTALK |
|-----------------------|----------|--------------|--------------------|--------------------|-------|-----------|
| HDMI 0dBFS/1KHz | HDMI | 0 dBFS | <0.01% | ±1dBFS | >80dB | <-80dB |
| | Optical | 0~-0.5 dBFS | <0.01% | ±1dBFS | >80dB | <-80dB |
| | Coaxial | 0~-0.5 dBFS | <0.01% | ±1dBFS | >80dB | <-80dB |
| | Line-Out | 2Vrms±0.2 | <0.1% | ±3dBFS | >80dB | <-80dB |
| | XLR L/R | 2Vrms±0.2 | <0.1% | ±3dBFS | >80dB | <-80dB |
| | Headphon | 2Vrms±0.2 | <0.1% | ±3dBFS | >80dB | <-75dB |
| OPTICAL 0dBFS/1KHz | HDMI | 0 dBFS | <0.01% | ±1dBFS | >80dB | <-80dB |
| | Optical | 0~-0.5 dBFS | <0.01% | ±1dBFS | >80dB | <-80dB |
| | Coaxial | 0~-0.5 dBFS | <0.01% | ±1dBFS | >80dB | <-80dB |
| | Line-Out | 2Vrms±0.2 | <0.1% | ±3dBFS | >80dB | <-80dB |
| | XLR L/R | 2Vrms±0.2 | <0.1% | ±3dBFS | >80dB | <-80dB |
| | Headphon | 2Vrms±0.2 | <0.1% | ±3dBFS | >80dB | <-75dB |
| COAX 0dBFS/1KHz | HDMI | 0~-0.5 dBFS | <0.01% | ±1dBFS | >80dB | <-80dB |
| | Optical | 0~-0.5 dBFS | <0.01% | ±1dBFS | >80dB | <-80dB |
| | Coaxial | 0~-0.5 dBFS | <0.01% | ±1dBFS | >80dB | <-80dB |
| | Line-Out | 2Vrms±0.2 | <0.1% | ±3dBFS | >80dB | <-80dB |
| | XLR L/R | 2Vrms±0.2 | <0.1% | ±3dBFS | >80dB | <-80dB |
| | Headphon | 2Vrms±0.2 | <0.1% | ±3dBFS | >80dB | <-75dB |
| LINE 0dBFS/1KHz | HDMI | 0~-1 dBFS | <0.01% | ±1dBFS | >80dB | <-80dB |
| | Optical | 0~-1 dBFS | <0.01% | ±1dBFS | >80dB | <-80dB |
| | Coaxial | 0~-1 dBFS | <0.01% | ±1dBFS | >80dB | <-80dB |
| | Line-Out | 2Vrms±0.2 | <0.1% | ±3dBFS | >80dB | <-80dB |
| | XLR L/R | 2Vrms±0.2 | <0.1% | ±3dBFS | >80dB | <-80dB |

| IN \ OUT | OUTPUT | OUTPUT LEVEL | T.H.D+N (A-WEIGHT) | FREQUENCY RESPONSE | SNR | CROSSTALK |
|---------------------|----------|--------------|--------------------|--------------------|-------|-----------|
| | Headphon | 2Vrms±0.2 | <0.1% | ±3dBFS | >80dB | <-75dB |
| FRONT 0dBFS/1KHz | HDMI | 0~-1 dBFS | <0.01% | ±1dBFS | >80dB | <-80dB |
| | Optical | 0~-1 dBFS | <0.01% | ±1dBFS | >80dB | <-80dB |
| | Coaxial | 0~-1 dBFS | <0.01% | ±1dBFS | >80dB | <-80dB |
| | Line-Out | 2Vrms±0.2 | <0.1% | ±3dBFS | >80dB | <-80dB |
| | XLR L/R | 2Vrms±0.2 | <0.1% | ±3dBFS | >80dB | <-80dB |
| | Headphon | 2Vrms±0.2 | <0.1% | ±3dBFS | >80dB | <-75dB |

9. ACRONYMS

| ACRONYM | COMPLETE TERM |
|-------------|--------------------------------------|
| COAX | Coaxial |
| HD | High Definition |
| HDMI | High-Definition Multimedia Interface |
| OLED | Organic Light-Emitting Diode |
| OPT | Optical |
| PLL | Phase Locked Loop |
| SRC | Sample Rate Conversion |
| THD | Total Harmonic Distortion |



CYPRESS TECHNOLOGY CO., LTD
Home page: <http://www.cypress.com.tw>

20130111 MPM-DCT21