

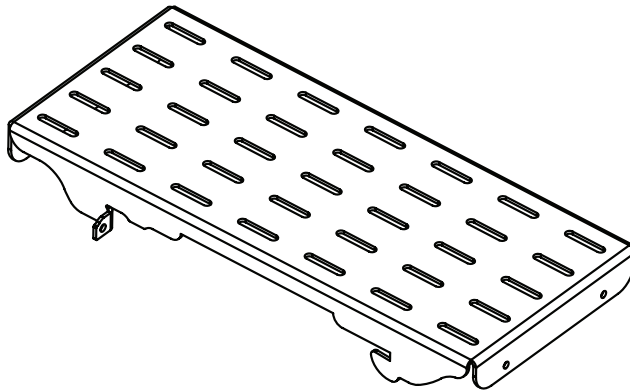

Installation and Assembly: Cable Management Bracket for Linear Display Mounting Kits

Model: DS-ACC-LDCM



Before you begin, make sure all parts shown are included with your product.

Parts List

Description	Qty.	Part Number
A cord management bracket	1	024-1046
B M5 x 25 mm socket pin screw	2	520-1122
C cable tie	4	560-9711

Some parts may appear slightly different than illustrated.

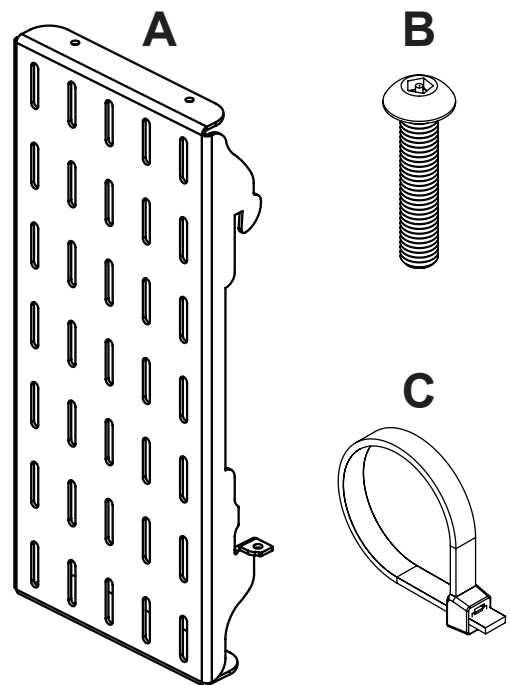

Attaching Cable Management Bracket

1 Hook cable management bracket (**A**) onto wall plate (SOLD SEPARATELY) and slowly swing down as shown in figure 1.1. Hand thread two M5 x 25 mm socket pin screws (**B**) through cable management bracket (**A**). Using 4 mm allen wrench (SUPPLIED WITH WALL PLATE), turn screws clockwise until screw tip securely contacts wall plate as shown in figure 1.2.

NOTE: Displays may need to be removed in order to access center of wall plate (SOLD SEPARATELY).

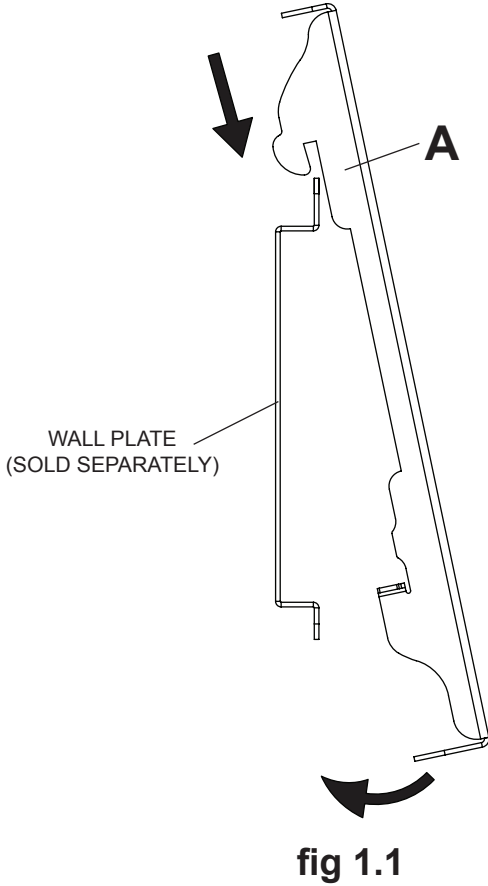

fig 1.1

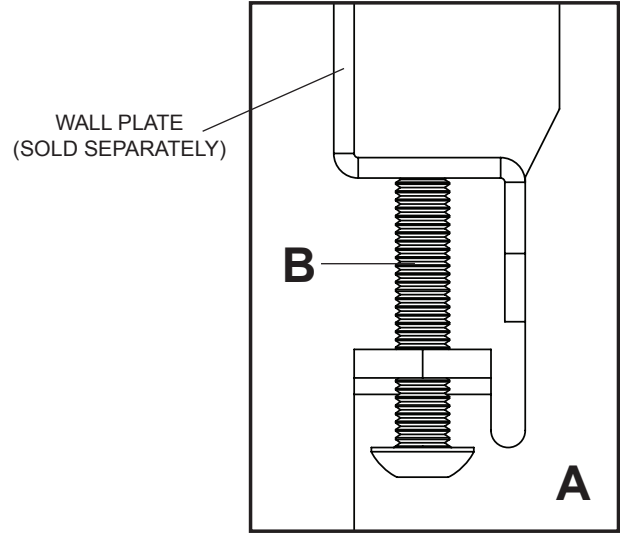

fig 1.2

1-1 Cables can be secured to cable management bracket (**A**) using cable ties (**C**) as shown below.

