

DS-S560-B2X2



Display size
46"-60"



Max load
800lb (363kg)
100lb per display

SMARTMOUNT.

Back-to-Back Modular Video Wall Pedestal Mount 2x2 Configuration

FOR 46" TO 60" DISPLAYS

Peerless-AV's Back-to-Back Modular Video Wall Pedestal Mount encompasses an assortment of useful features that eliminate the need for extra tools and hardware, all while ensuring your application is secure and looks professional. The DS-S560-B2X2's tool-less micro adjustment provides the time saving feature you need for perfect display alignment. The built-in cable management creates a clean and clutter-free appearance. If you're looking for added stability, this mount can be mounted to concrete structures without additional wall or ceiling supports in any retail, public transportation or any other high traffic location.

Tool-less micro-adjustment at 8 points helps seamlessly align the displays, creating the ultimate video wall solution.



Additional Features

- ✓ Adaptors feature a quick connect latch for automatic engagement with the mounting rails and ease of set-up
- ✓ Cable management through adjustable cable centralizing brackets
- ✓ Aluminum frame reduces the overall weight and shipping costs
- ✓ VESA® 200 x 200 up to 600 x 400mm compatible

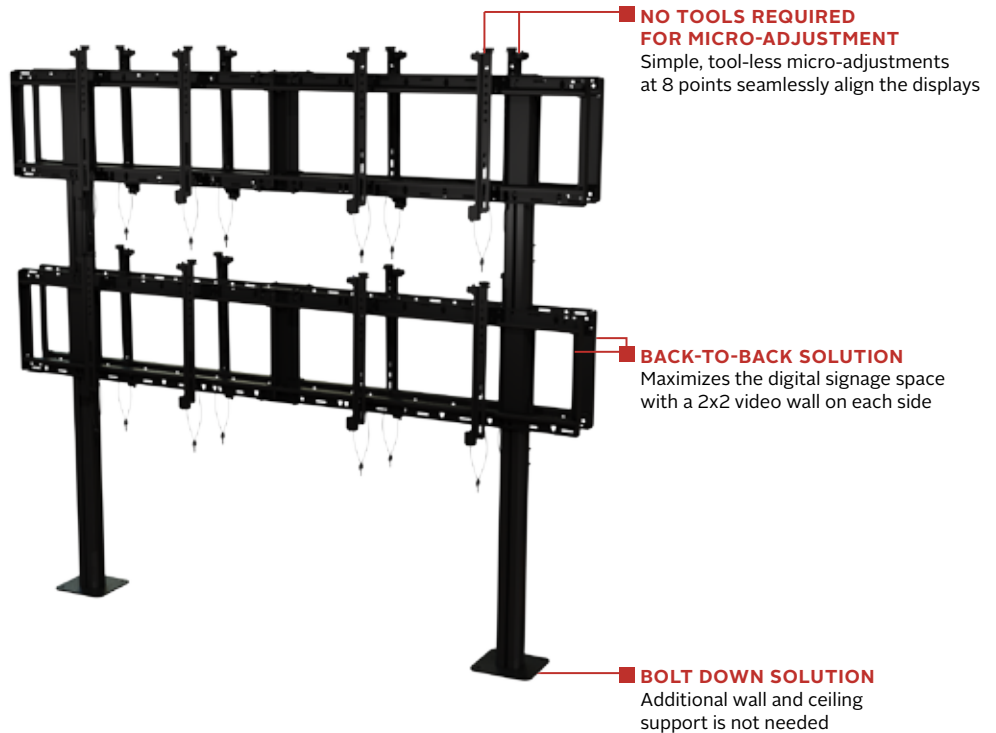

DS-S560-B2X2 SmartMount® Back-to-Back Modular Video Wall Pedestal Mount 2x2 Configuration for 46" to 60" Displays

Product Specifications

	DIMENSIONS (W x H x D)	PRODUCT WEIGHT	LOAD CAPACITY	FINISH	AVAILABLE COLORS
DS-S560-B2X2	80.61" x 75.35" x 10.35" (2047 x 1914 x 263mm)	257lb (117kg)	800lb (363kg) 100lb per display	Powder Coat	Black

Package Specifications

	PACKAGE SIZE (W x H x D)	PACKAGE SHIP WEIGHT	PACKAGE UPC CODE	PACKAGE CONTENTS	UNITS IN PACKAGE
DS-S560-B2X2	85.00" x 37.50" x 12.50" (2159 x 952 x 317mm)	345lb (157kg)	735029308218	Stand, display adaptors and hardware	1

COMPATIBILITY FORMULA

Display height ≤ 36"
 Display width ≥ 40.5"
 Display width + mount pattern width ≤ 80"

All dimensions = inch (mm)

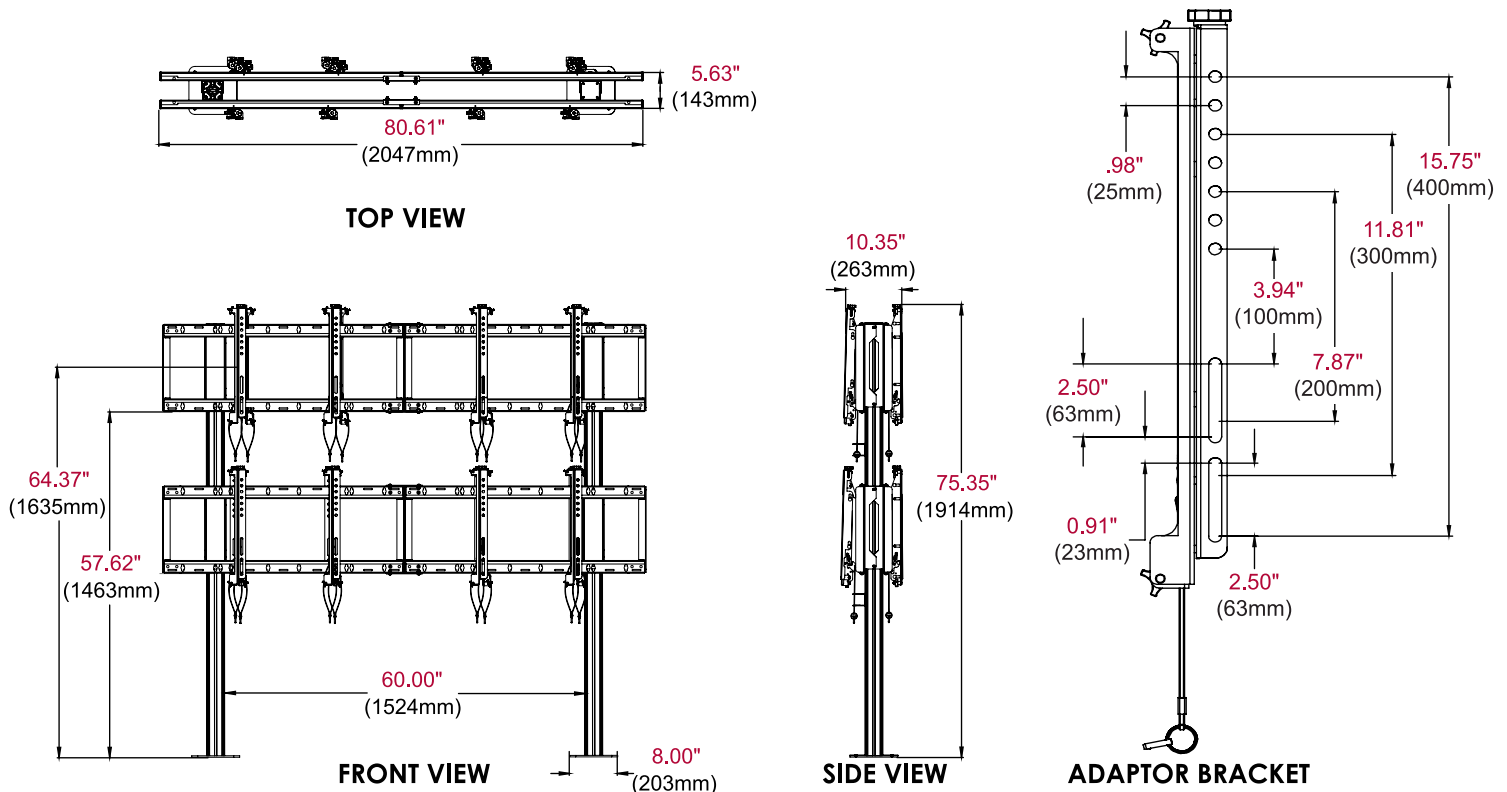

Architect Specifications

The Smartmount® Back-to-Back Modular Video Wall Pedestal Mount 2x2 Configuration shall be a Peerless-AV model DS-S560-B2X2 and shall be located where indicated on the plans. Assembly and installation shall be done according to instructions provided by the manufacturer.

Visit peerless-av.com to see the complete line of AV solutions from Peerless-AV, including outdoor displays, wireless, kiosks, digital audio, display mounts, projector mounts, carts/stands, and a full assortment of accessories.

Peerless-AV
 2300 White Oak Circle
 Aurora, IL 60502 USA
(800) 865-2112
(630) 375-5100
Fax: (800) 359-6500

Peerless-AV Europe
 Unit 3 Watford Interchange
 Colonial Way, Watford
 Herts, WD24 4WP
 United Kingdom
+44 (0) 1923 200100
Fax: +44 (0) 1923 200101

Peerless-AV de México
 Ave de las Industrias 413
 Parque Industrial Escobedo
 Escobedo, N.L.,
 Mexico 66050
+52 (81) 8384-8300
Fax: +52 (81) 8384-8360

