

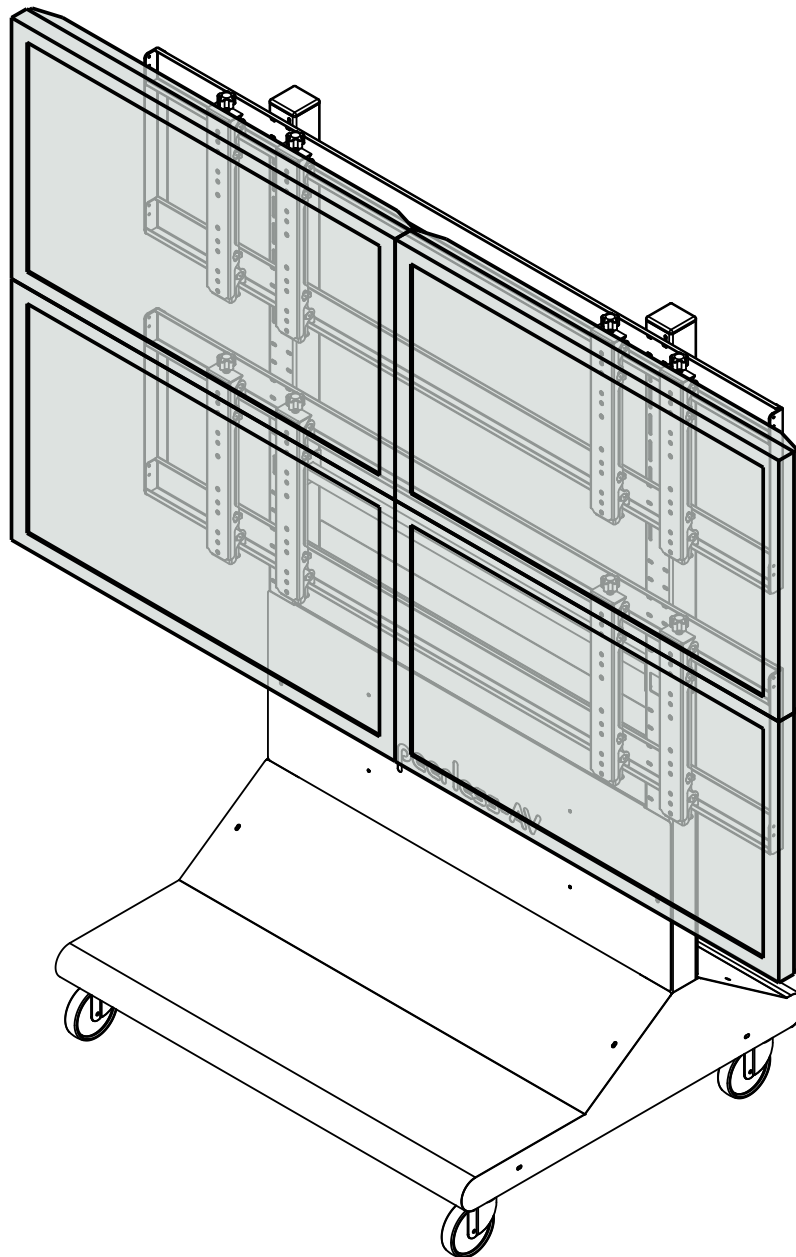

Installation and Assembly: 2 x 2 Cart

Model: DS-VWC560



Maximum Load Capacity 500 lbs (227 kg)

PARTS LIST

Description	Qty.	Part #
A vertical support	2	145-1389
B adapter brackets	8	145-1711
C horizontal support	3	124-1852
D horizontal rail	2	145-1238
E 5" caster [127mm]	4	600-0026
F 1/4" flat washer [6mm]	56	540-9440
G M8 x 25 mm phillips screw	16	520-1031
H 5/16 flat washer [7mm]	16	540-9406
I 5/16 split washer [7mm]	16	540-9405
J 1/4-20 x 3.5" hex head screw	56	520-1656
K 1/4-20 nylock nut	56	530-9413
L .38 OD x .06 LG nylon washer [9mm]	16	590-2233
M 18" mesh sleeve	4	600-1014
N M8 x 16 mm phillips screw	16	520-9257
O M6 x 12 mm phillips screw	16	520-1128
P 4 mm allen wrench	4	560-9646
Q cable tie	8	560-9711
R tube cap	2	590-1289
S M5 x 10 mm socket pin screw (not used)	8	520-1164
T #14 fender washer (not used) [9mm]	16	540-1008
U front bottom cover	1	145-1364
V back bottom cover	1	145-1363
W component shelf	1	145-1361
X side cover	2	145-1362
Y decorative screw	12	520-2326
Z spacer	4	590-1136
AA front top cover	1	145-1388
BB back top cover	1	145-1368
CC self-drilling phillips screw	3	520-1320

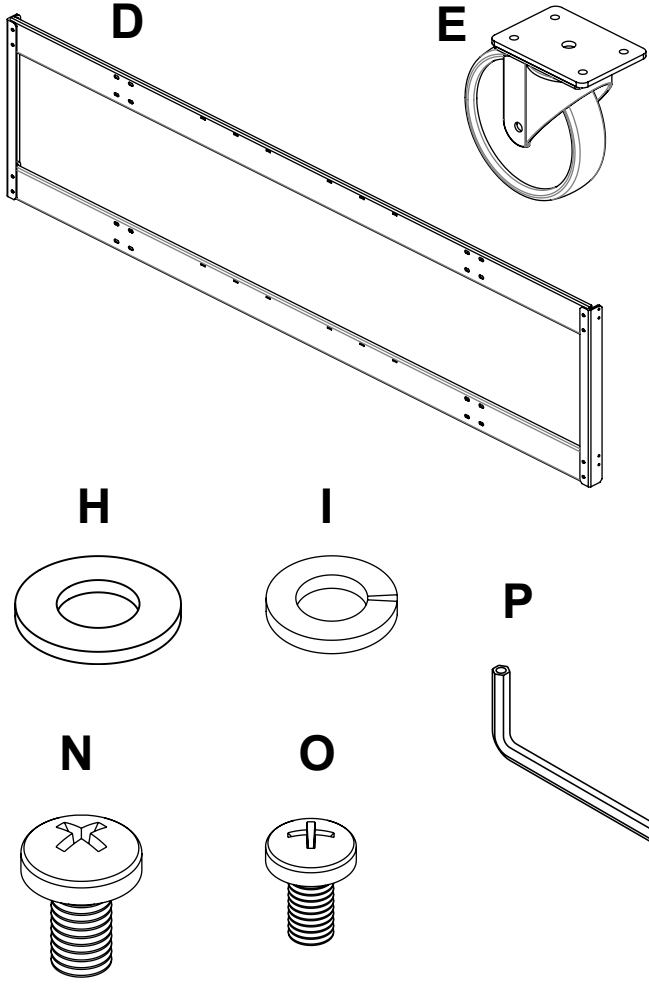
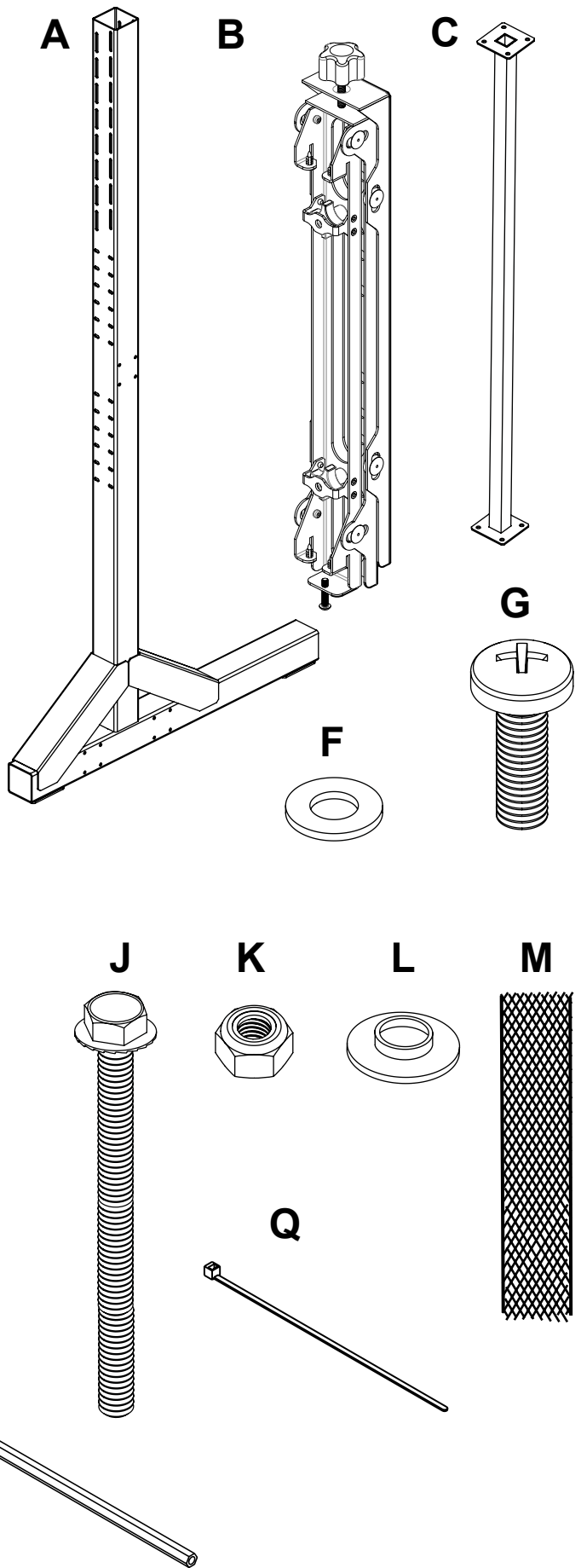

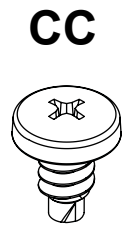
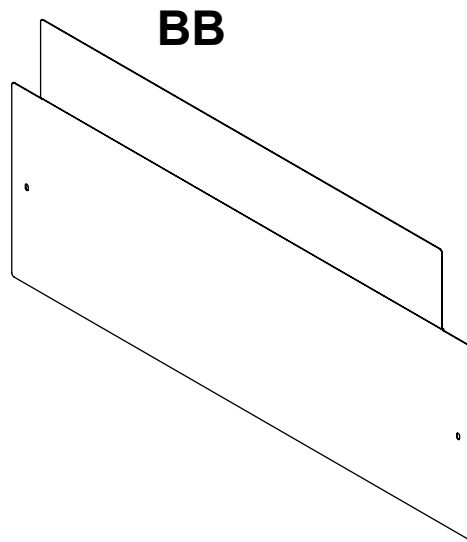
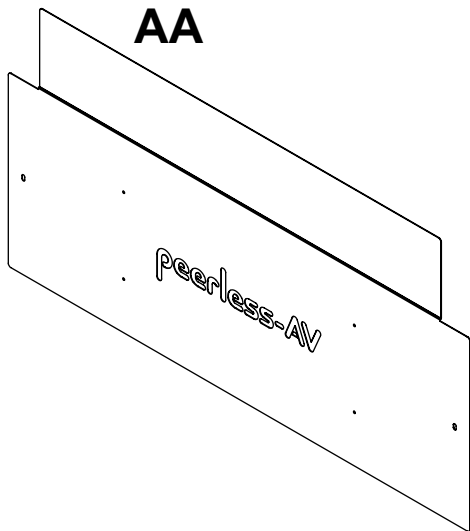
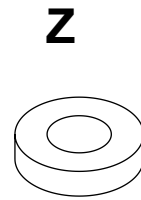
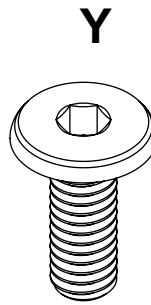
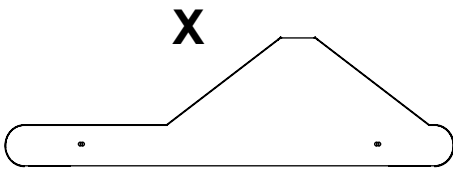
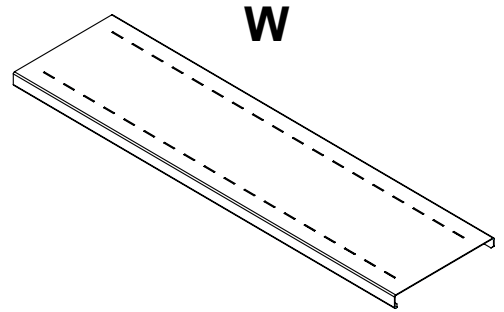
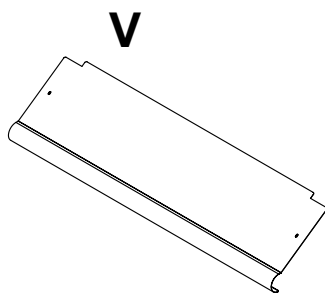
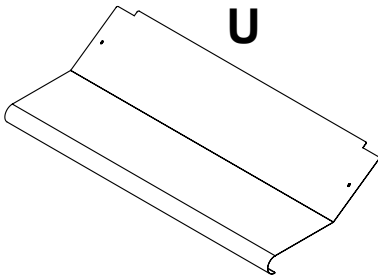
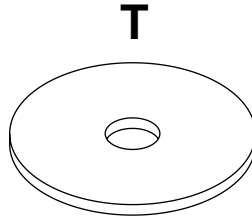
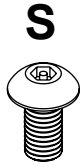
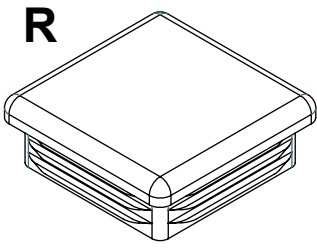

NOTE: Read entire instruction sheet before you start installation and assembly.

⚠ WARNING

- Do not begin to install your Peerless product until you have read and understood the instructions and warnings contained in this Installation Sheet. If you have any questions regarding any of the instructions or warnings, for US customers please call Peerless customer care at 1-800-865-2112, for all international customers, please contact your local distributor.
- This product should only be installed by someone of good mechanical aptitude, has experience with basic building construction, and fully understands these instructions.
- Make sure that the supporting surface will safely support the combined load of the equipment and all attached hardware and components.
- Never exceed the Maximum UL Load Capacity. See page one.
- If mounting to wood wall studs, make sure that mounting screws are anchored into the center of the studs. Use of an "edge to edge" stud finder is highly recommended.
- Always use an assistant or mechanical lifting equipment to safely lift and position equipment.
- Tighten screws firmly, but do not overtighten. Overtightening can damage the items, greatly reducing their holding power.
- This product is intended for indoor use only. Use of this product outdoors could lead to product failure and personal injury.

Tools Needed for Assembly

- socket wrench
- phillips screwdriver
- hammer

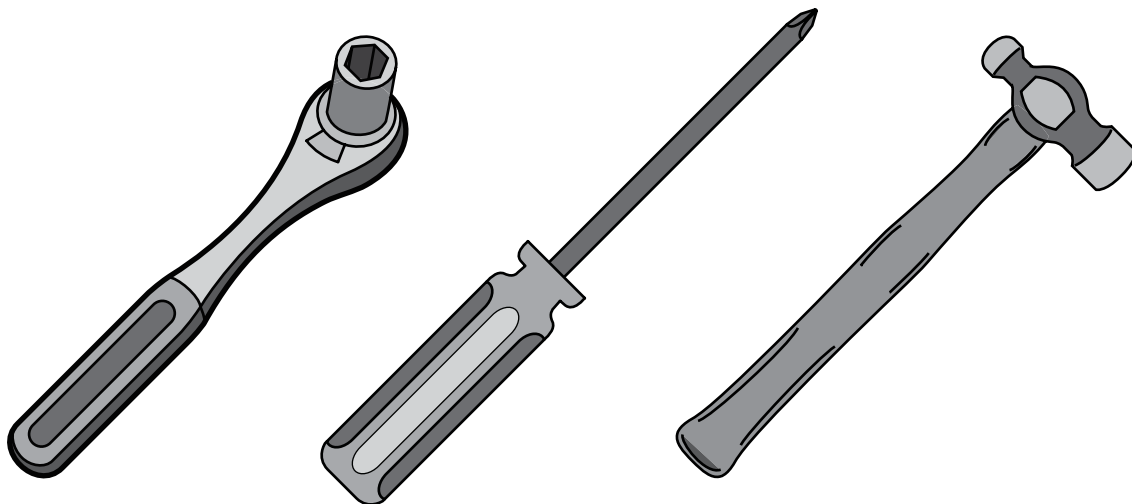

Assembling Cart

- 1** Attach two horizontal supports (C) to vertical support (A) using eight 1/4-20 x 3.5" hex head screws (J), 1/4" SAE washers [6mm] (F) and 1/4-20 nylock nuts (K).

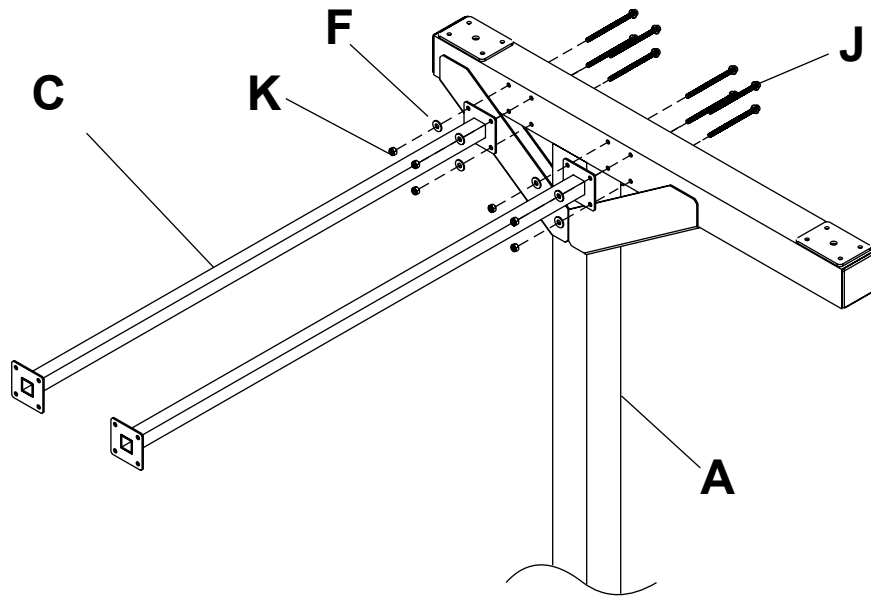

- 2** Attach horizontal supports (C) to second vertical support (A) using eight 1/4-20 x 3.5" hex head screws (J), 1/4" SAE washers [6mm] (F) and 1/4-20 nylock nuts (K).

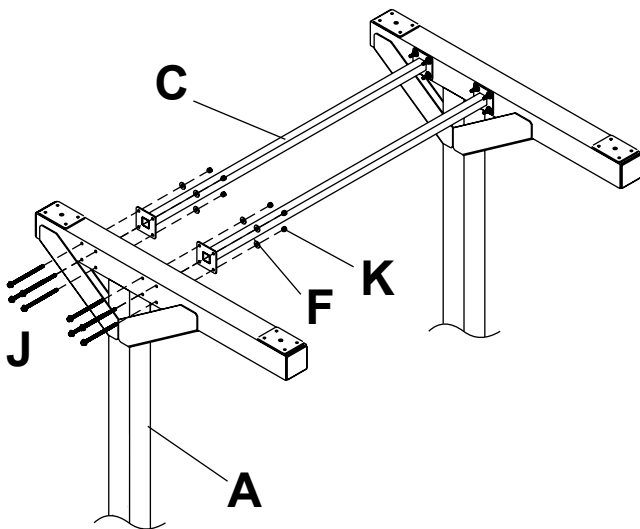

- 3** Attach horizontal support (C) to vertical supports (A) using eight 1/4-20 x 3.5" hex head screws (J), 1/4" SAE washers [6mm] (F) and 1/4-20 nylock nuts (K).

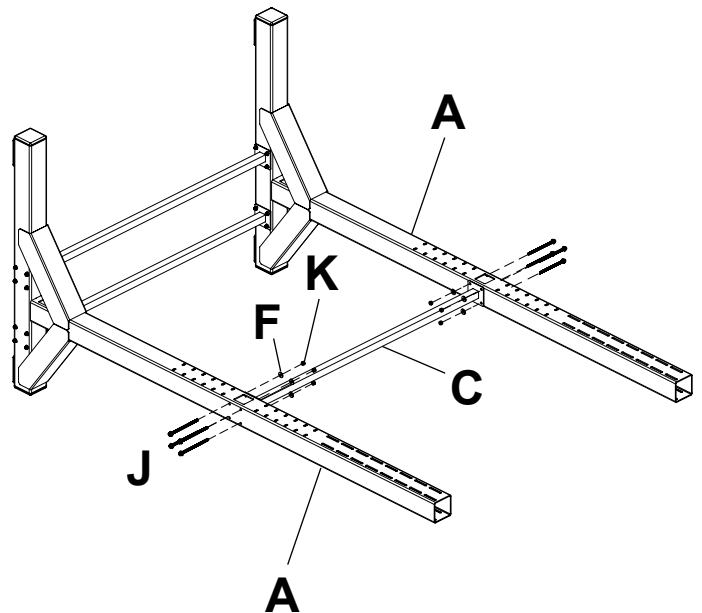

- 4** Attach four swivel casters [127mm] (E) to vertical supports (A) using sixteen M8 x 25 mm pan phillips screws (G), split washers (I) and 5/16" SAE flat washers [8mm] (H).

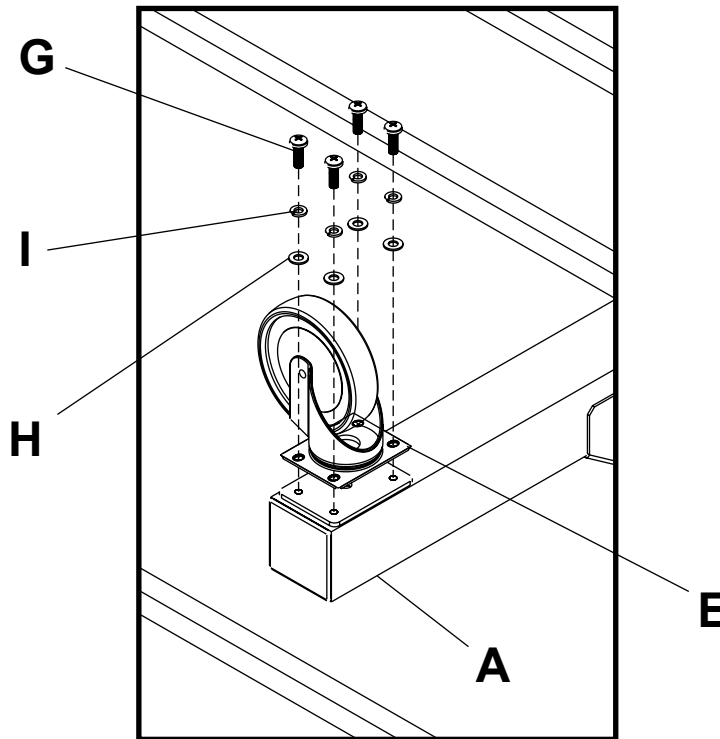

- 5** Determine position of horizontal rails (D) using the formula below.
1. Locate the position of the lower horizontal rail (D) and attach to vertical supports (A).
 2. Use display height to determine location of upper horizontal rail (D),
- NOTE:** Lowest horizontal rail (D) position shown in detail 1.
NOTE: Horizontal rails (D) must be secured using sixteen 1/4-20 x 3.5" hex head screws (J).

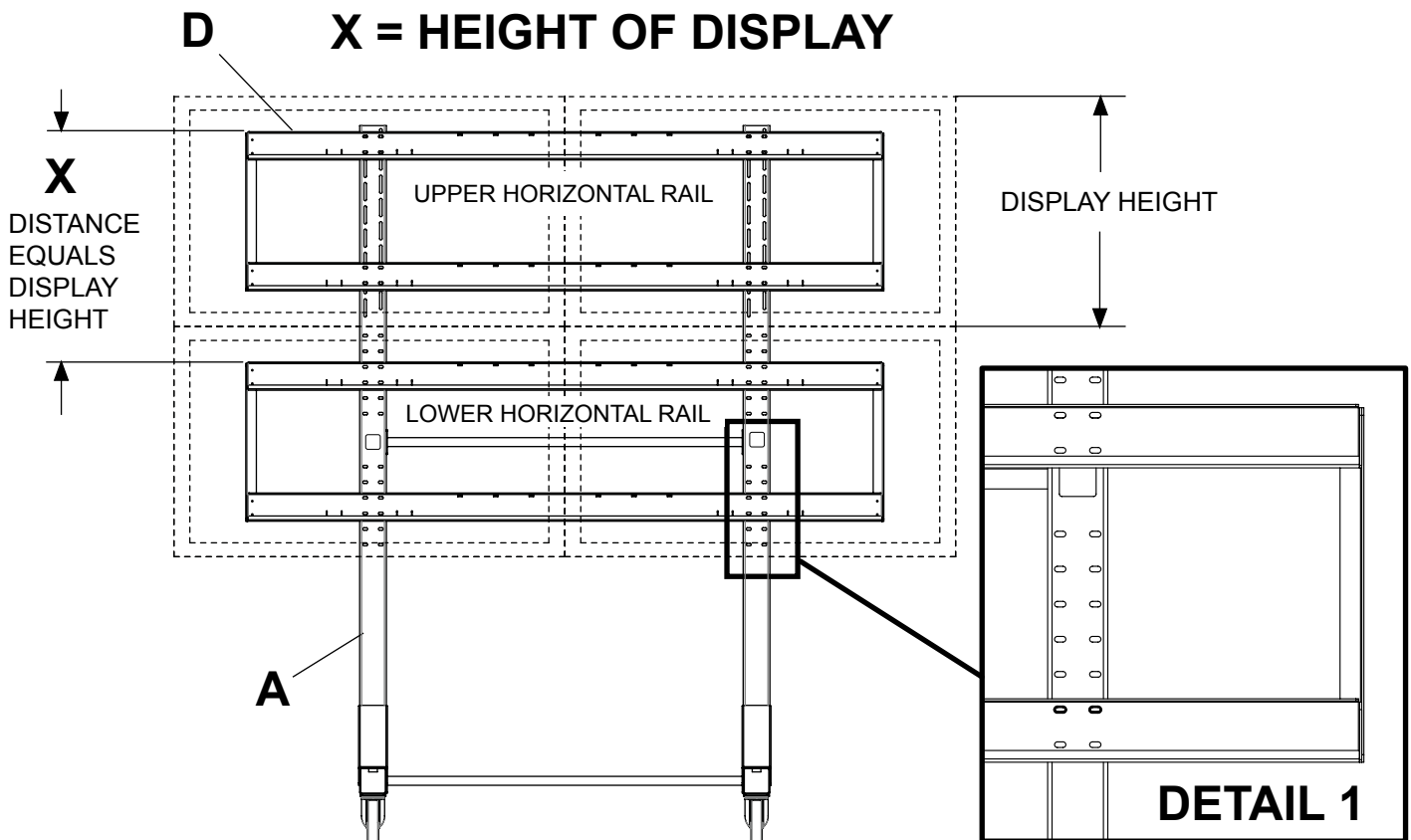

- 6** Attach horizontal rails (**D**) onto vertical supports (**A**) using sixteen 1/4-20 x 3.5" hex head screws (**J**), 1/4" SAE washers [6mm] (**H**) and 1/4-20 nylock nuts (**K**) as shown in detail 1. Make sure that horizontal rails (**D**) are level then tighten all 1/4-20 x 3.5" hex head screws (**J**). Place two tube caps (**R**) into tops of vertical supports (**A**) as shown in detail 2. **NOTE:** horizontal rails (**D**) must be secured using sixteen 1/4-20 x 3.5" hex head screws (**J**).

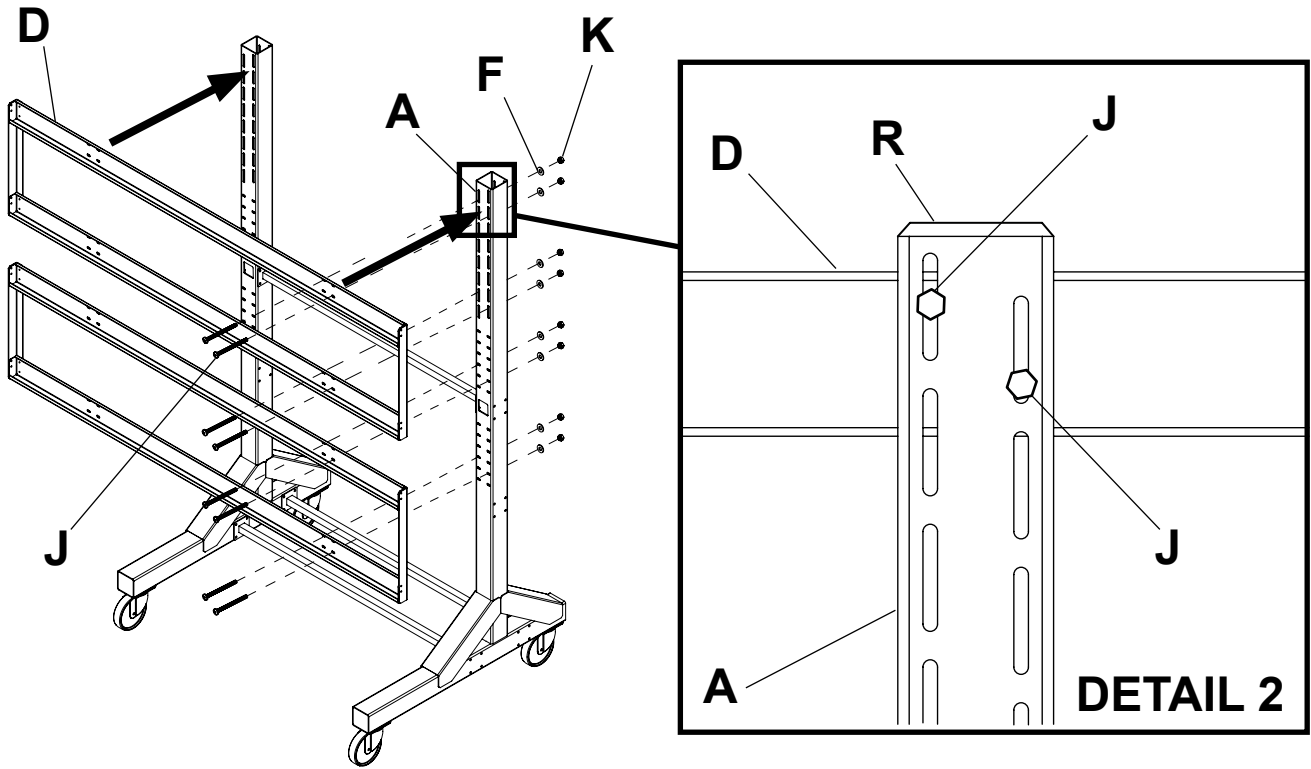

CABLE MANAGEMENT

- 7** Run display cables through top and bottom openings in vertical supports (**A**) as shown. **NOTE:** Display cables can be covered using 18" mesh sleeve (**M**) before securing.

Display cables can be secured to horizontal rails (**D**) using eight cable ties (**Q**) as needed through slots in horizontal rails (**D**).

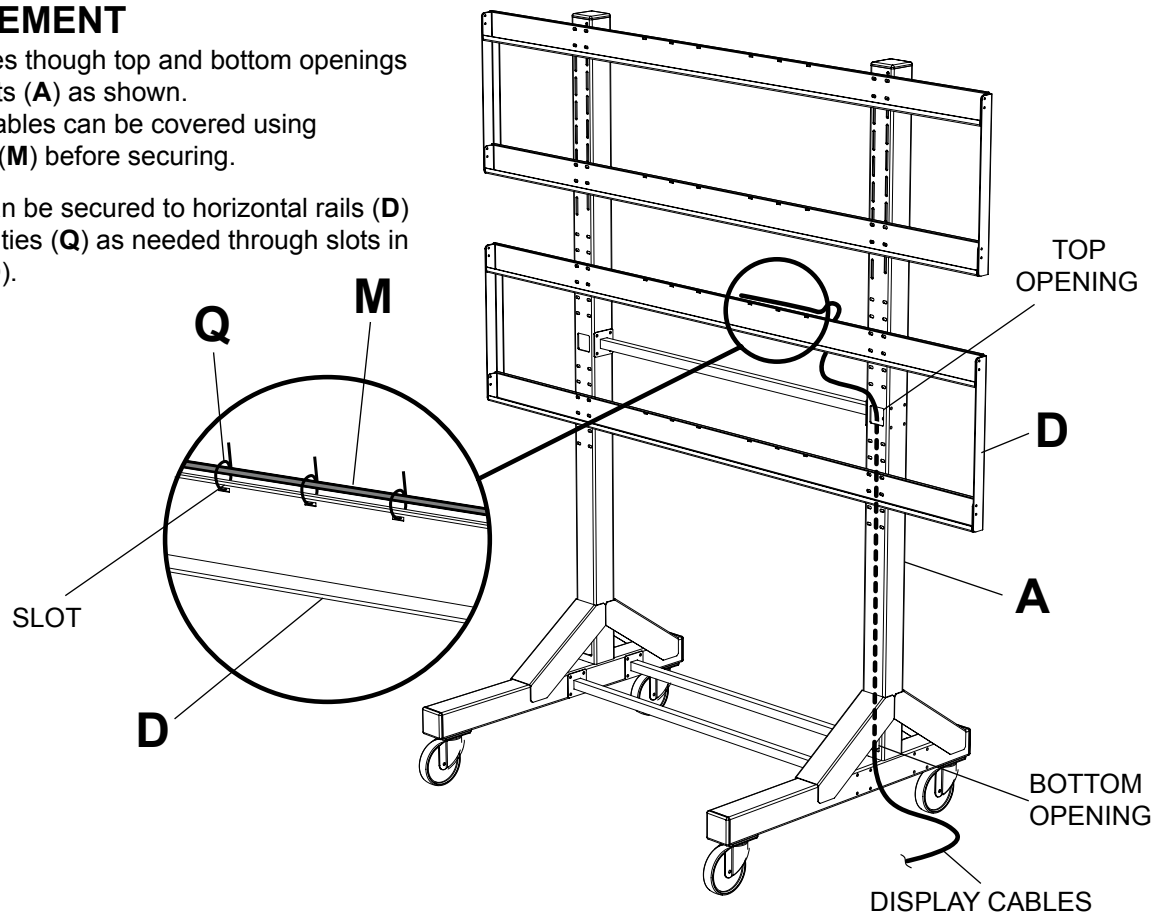

8 Attach adapter brackets (**B**) to back of display using four M6 x 12 mm phillips screws (**O**) with nylon shoulder washer [4mm] (**L**), or four M8 x 15 mm phillips screws (**N**) as shown below.

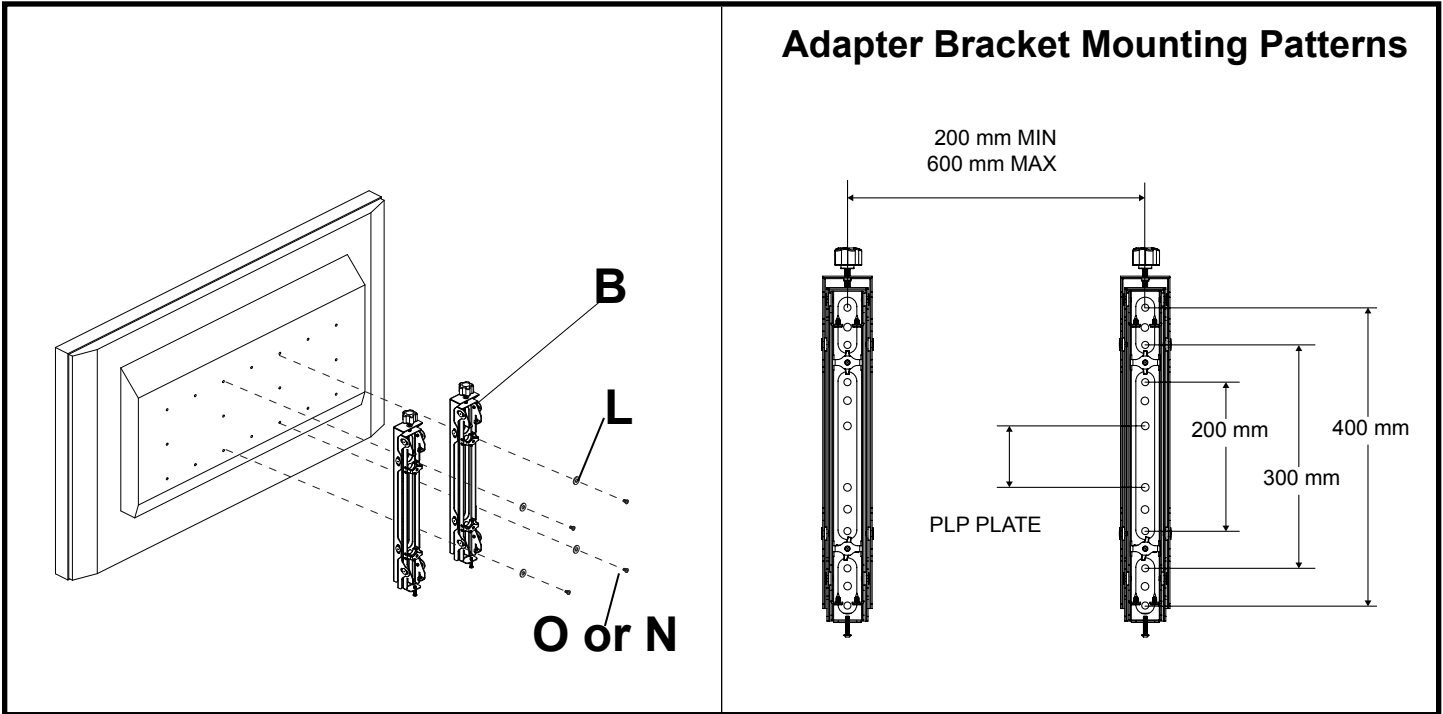

Adapter Bracket Placement Detail

8.1 Use detail 3 to figure adapter bracket (**B**) placement.

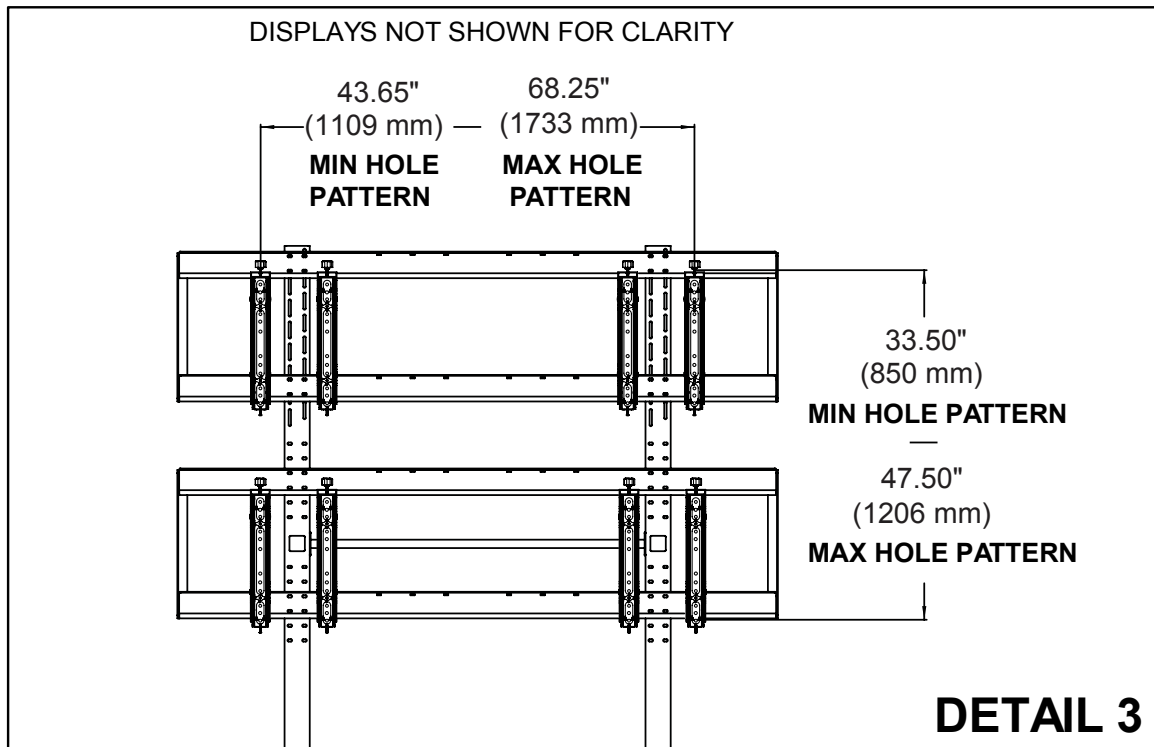

8.2

Attach adapter brackets using the PLP Setup (B) using the M10 screws that are supplied with the PLP plate.

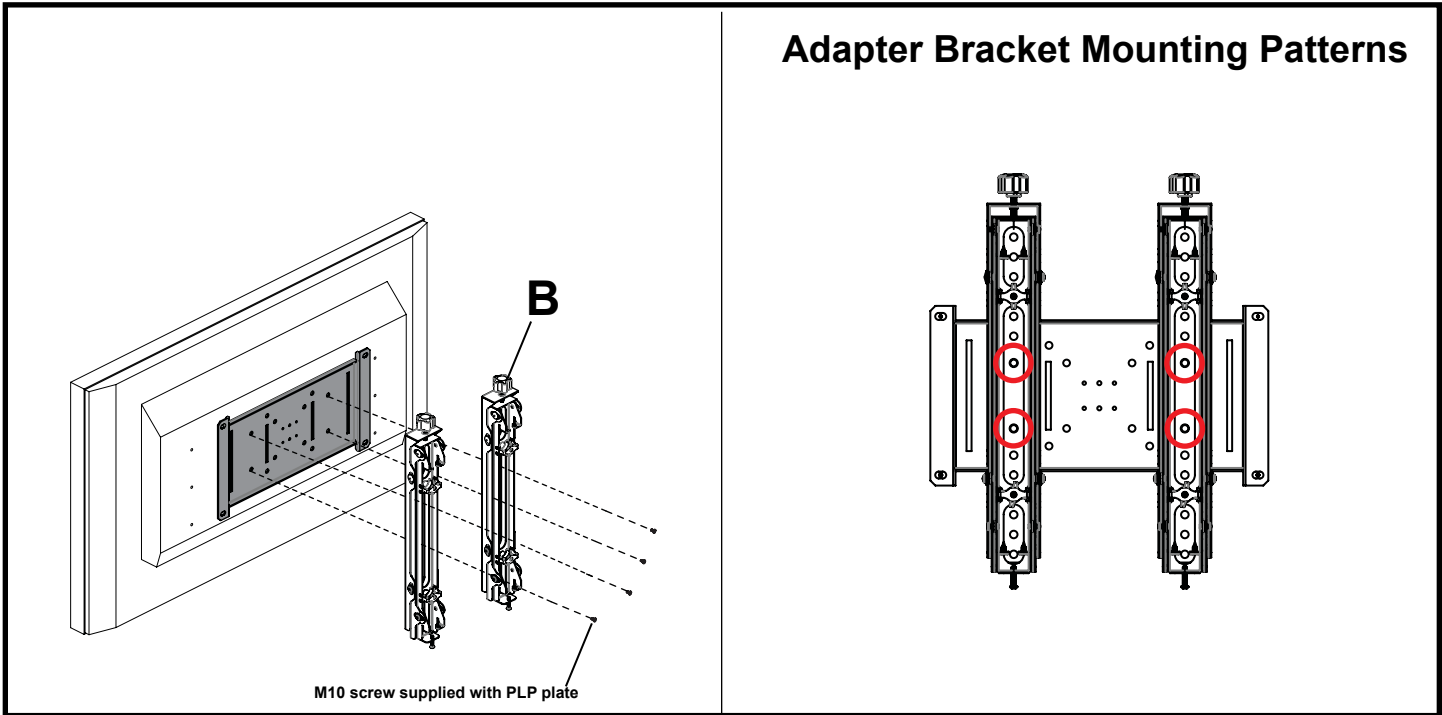

- 9** Hook display and adapter brackets (**B**) onto horizontal rail (**D**) as shown below.
NOTE: Hang displays in sequenced order.

NOTE: Once display is located in desired position, tighten security screws as shown in detail 4.

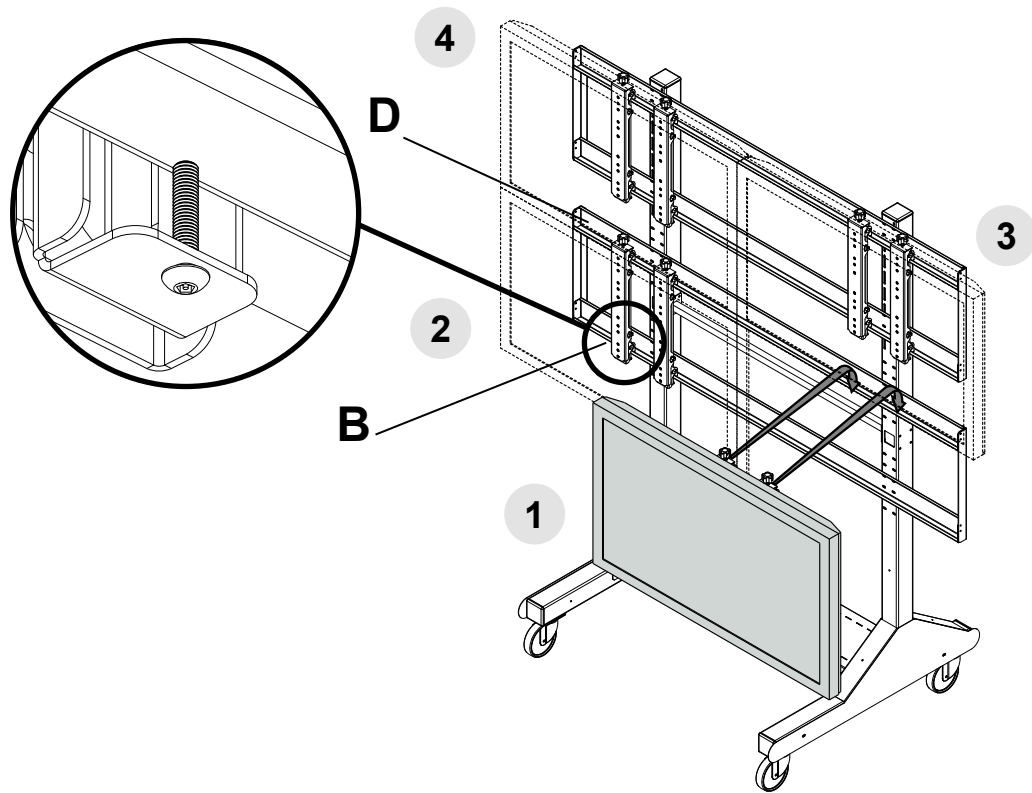

Attaching Component Shelf (Optional)

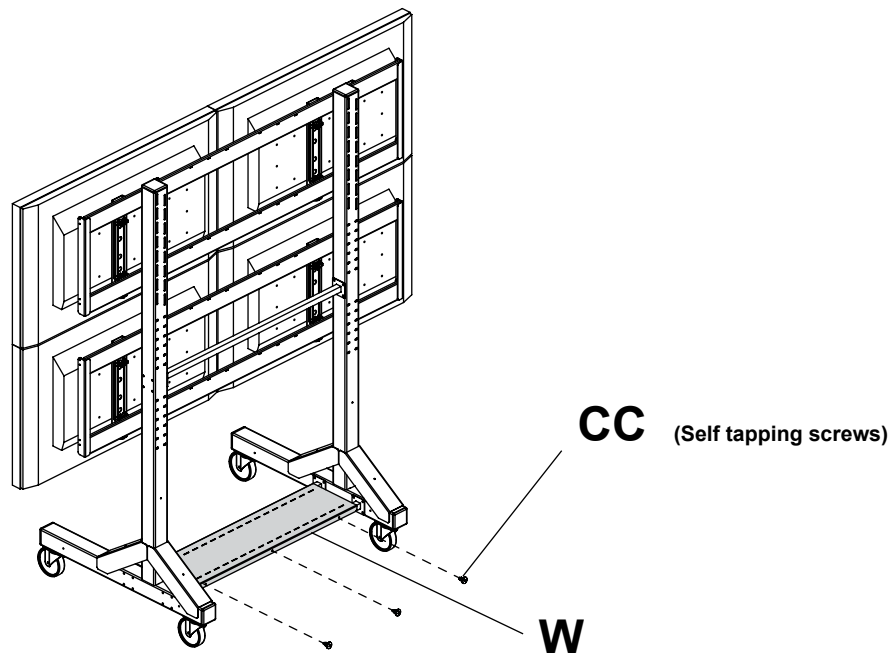

- 10** Fasten component shelf (**W**) onto horizontal support (**C**) using three self-tapping phillips screws (**CC**) as shown below.





Adapter Bracket Adjustment

11 Use legend below to determine position of display.

NOTE: Each knob can be adjusted independently for fine tuning angle adjustments.

 Turn knobs **CLOCKWISE** to raise display height.
 Turn knobs **COUNTER-CLOCKWISE** to lower display height.

 Turn knobs **CLOCKWISE** to push out display.
 Turn knob **COUNTER-CLOCKWISE** to pull in display.

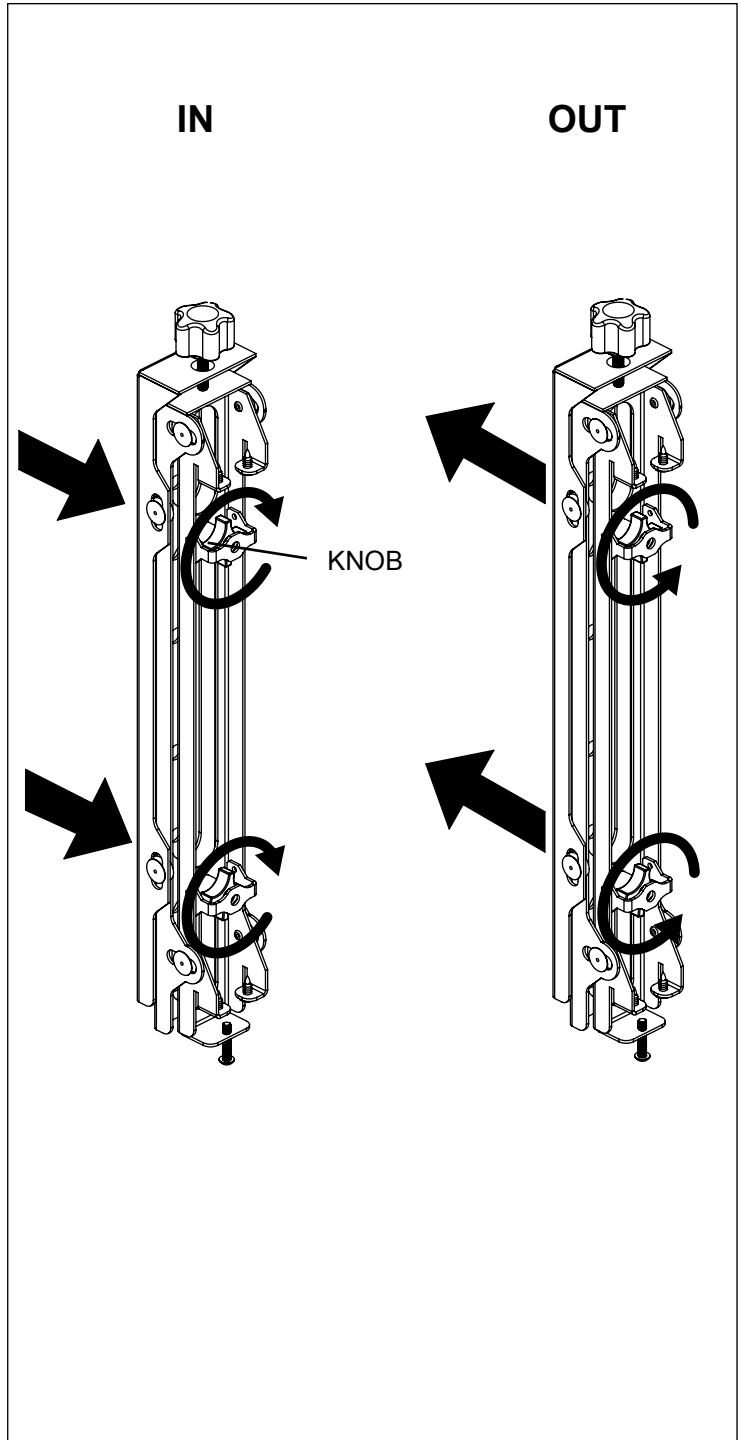
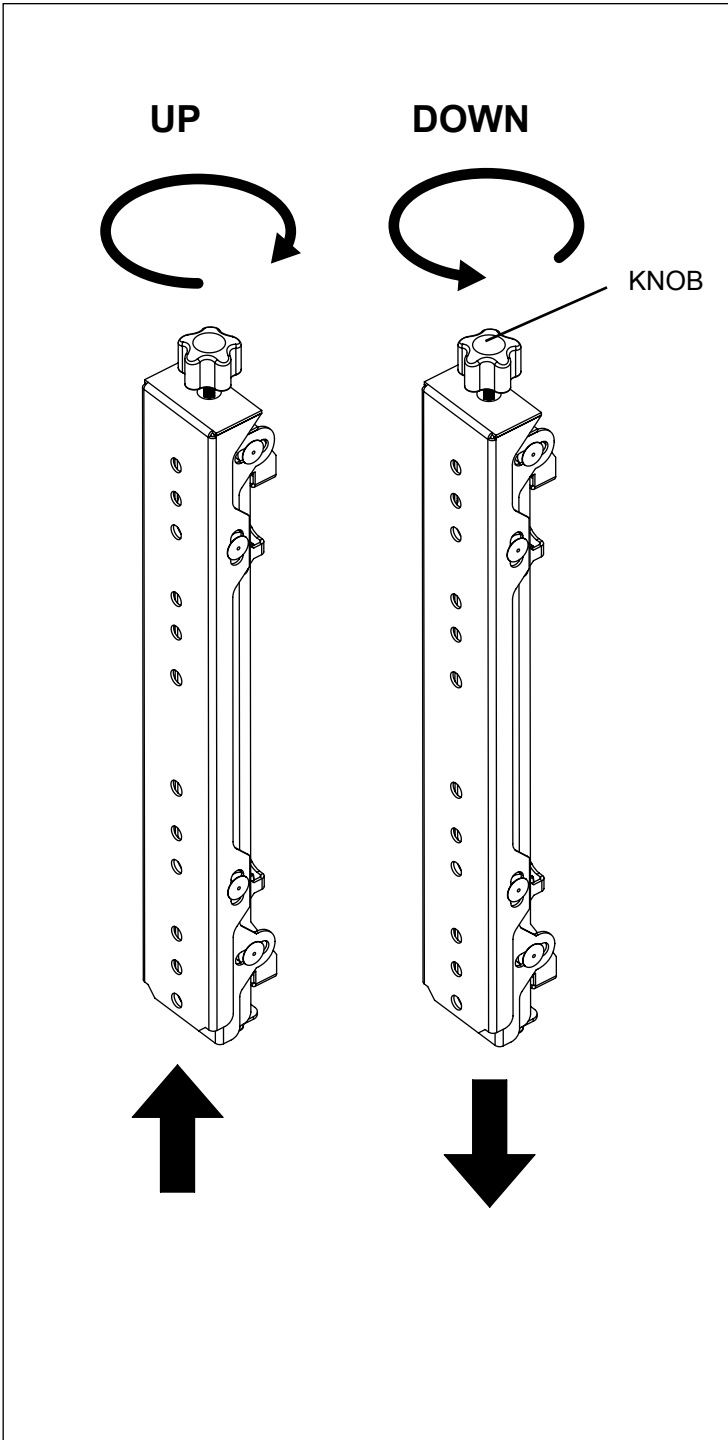

Attaching Covers

12

NOTE: Position bottom front and back covers first

Position front bottom cover (**U**). Secure covers in place using four decorative screws (**Y**) as shown below.

Position back bottom cover (**V**). Secure covers in place using four decorative screws (**Y**) as shown below.

Position front top cover (**AA**). Secure covers in place using four decorative screws (**Y**) as shown below.

Position back top cover (**BB**). Secure covers in place using four decorative screws (**Y**) as shown below.

Optional: Front top cover (**AA**), and back top cover (**BB**) can be interchanged.

Attach two retaining spacers (**Z**), and decorative screws (**Y**) to side cover (**X**) as shown in detail 5.

Attach side covers to vertical supports (**A**).

