

DS039

108" Cart / Stand

For Sharp 108" LC-108D1U Displays

Peerless-AV cart/stand supports one of the largest flat panel displays in the World - the Sharp 108" LCD (LC-108D1U). The cart/stand features an ultra-strong tubular frame and provides the flexibility to be used as either a transportable cart or a stationary stand (with Peerless-AV ACC310 leg leveler kit). Its durable ball bearing casters provide smooth rolling motion on level surfaces for simple travel from one location to the next. Openings in the product's upright support system provide a convenient location for neatly stowing cabling for a clean, organized appearance. The Peerless-AV cart/stand solution provides the ultimate stationary and mobile solution for Sharp's 108" flat panel displays.



Screen size: 108"



Max load: 600lb (272kg)

FEATURES

- Designed to hold the Sharp LC-108D1U
- Internal cable management hides cables for a clean, clutter-free appearance
- Speedy transition from a cart to a stand with Peerless leg accessory leveler kit (ACC310)
- 360° swivel ball-bearing casters for smooth motion; allowing ease of cart maneuverability
- Tubular steel frame design with welded, gusseted uprights ensures strength and durability
- Supports up to 600lb (272kg)



Internal Cable Management



ACC310 - Cart to Stand Conversion Kit

RoHS
2002/95/EC

CLICK: www.peerless-av.com

CALL: 800.865.2112

FAX: 800.359.6500

peerless-AV

DS039: Cart / Stand for Sharp 108" (LC-108D1U) Displays

Product Specifications

	DIMENSIONS (W x H x D)	PRODUCT WEIGHT	LOAD CAPACITY	FINISH	AVAILABLE COLORS
DS039	61.11" x 82.16" x 31.00" (1552 x 2087 x 787mm)	162lb (73.5kg)	600lb (272kg)	Scratch resistant fused epoxy	Black

Package Specifications

	PACKAGE SIZE (W x H x D)	PACKAGE SHIP WEIGHT	PACKAGE UPC CODE	PACKAGE CONTENTS	UNITS IN PACKAGE
DS039	Box 1: 57" x 26.75" x 6" (1448 x 680 x 153mm) Box 2: 4" x 4" x 72" (102 x 102 x 1829mm) Box 3: 4" x 4" x 72" (102 x 102 x 1829mm)	181lb (82.1kg)	735029262169	Tube Support Structure, Left and Right Foot Assemblies, Wheel Casters, Adapter Bracket, Back Plate, Fastener Packet	1

Accessories

ACC310: Leg Leveler Kit

All dimensions = inch (mm)

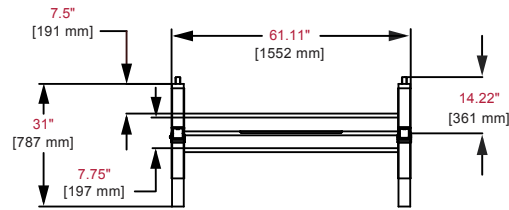

TOP VIEW

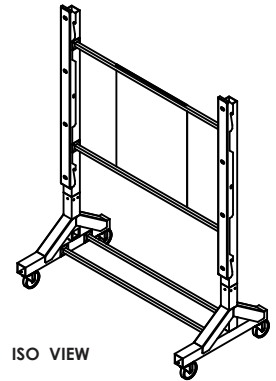

ISO VIEW

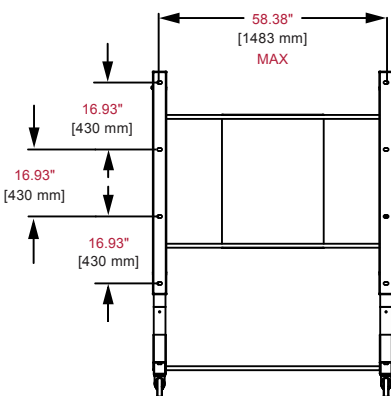

MOUNTING HOLE PATTERN

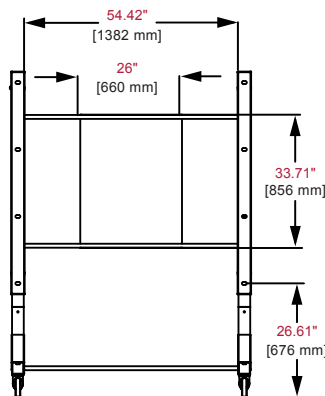

FRONT VIEW

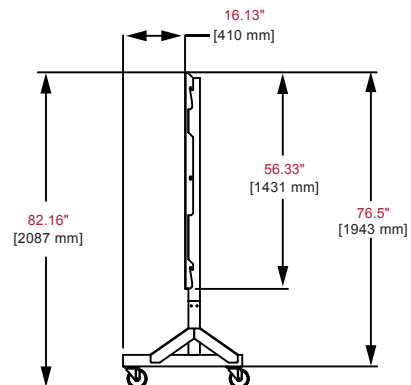

RIGHT VIEW

ARCHITECTS SPECIFICATIONS

The Cart/Stand shall be a Peerless-AV model DS039 and shall be located where indicated on the plans. It shall be constructed of heavy gauge cold rolled steel tubing, and finished with scratch resistant Black Fused Epoxy. Assembly and installation shall be done according to instructions provided by the manufacturer.