

GefenPRO

1080P
PROGRESSIVE



16x16 DVI Matrix

GEF-DVI-16416

User Manual

www.gefenpro.com

ASKING FOR ASSISTANCE

Technical Support:

Telephone (818) 772-9100
(800) 545-6900

Fax (818) 772-9120

Technical Support Hours:

8:00 AM - 5:00 PM Monday - Friday, Pacific Time

For 24 / 7 support, see the back of the product for the support number

Write To:

Gefen LLC
c/o Customer Service
20600 Nordhoff St
Chatsworth, CA 91311

www.gefenpro.com
support@gefenpro.com

Notice

Gefen LLC reserves the right to make changes in the hardware, packaging and any accompanying documentation without prior written notice.

16x16 DVI Matrix is a trademark of Gefen LLC

© 2010 Gefen LLC, All Rights Reserved
All trademarks are the property of their respective owners

Rev C10
4.10

CONTENTS

- 1 Introduction
- 2 Operation Notes
- 3 Features
- 4 Front Panel Layout
- 5 Front Panel Descriptions
- 6 Back Panel Layout
- 7 Back Panel Descriptions
- 8 Connecting And Operating The GefenPRO 16x16 DVI Matrix
- 8 Wiring Diagram
- 9 Front Panel Display
- 11 IR Remote Description
- 12 IR Remote Installation
- 13 IR Remote Configuration
- 14 EDID Management Feature
- 15 RS-232 Serial Control Interface
- 16 RS-232 Serial Control Commands
 - 16 Commands
 - 19 EDID Management
 - 24 IP Configuration
 - 27 General Functions
- 31 IP Control
 - 31 Main Page
 - 32 Manage EDID
 - 36 Masking
 - 37 IP Configuration
 - 38 Backup / Restore & Power Management
- 39 Firmware Update
- 41 Rack Mount Safety Information
- 42 Specifications
- 43 Warranty
- 44 Licensing

INTRODUCTION

Congratulations on your purchase of the GefenPRO 16x16 DVI Matrix. Your complete satisfaction is very important to us.

All GefenPRO products include 24/7 customer support from trained technical service representatives available at Gefen. This enhanced customer service is ideal for highly demanding industries such as broadcasting and the rental/staging markets.

GefenPRO

In the realm of video distribution, certain features are invaluable in a commercial or broadcast environment. Accommodations such as a build-in power supply and flat black rack-mount enclosures set GefenPRO apart from our traditional products. Complex distribution units allow for professional DVI, 3G-SDI, and HDMI signals to be routed and converted easily and seamlessly, while being backed up by a renowned and dependable technical support team. Gefen invites you to explore the GefenPRO product line and hopes that you find the solution that fits your needs.

The GefenPRO 16x16 DVI Matrix

Simplify the process of routing up to 16 DVI sources to any of 16 DVI monitors without losing quality or resolution. The GefenPRO 16x16 DVI Matrix provides a simple, reliable, and highly effective method of streamlining any installation using multiple sources and outputs, taking the hassle out of managing multiple connections. Each DVI source is accessible at all times by any monitor using the front-panel buttons, IR remote unit, built-in RS-232 or using IP control.

How It Works

The GefenPRO 16x16 DVI Matrix has 16 DVI inputs and 16 DVI outputs. Using the supplied DVI cables, connect 16 sources to the DVI input ports on the GefenPRO 16x16 DVI Matrix's input side. Connect the GefenPRO 16x16 DVI Matrix's 16 DVI outputs to the monitors. Plug in the power cord and power on the GefenPRO 16x16 DVI Matrix. The connected monitors will show video according to the routing selection.

NOTE: The GefenPRO 16x16 DVI Matrix only supports DVI-D. The DVI connectors on the GefenPRO 16x16 DVI Matrix have all 29 pins.

OPERATION NOTES

READ THESE NOTES BEFORE INSTALLING OR OPERATING THE GEFENPRO 16X16 DVI MATRIX

- The GefenPRO 16x16 DVI Matrix does not support HDCP content.
- Make sure that a DVI monitor is powered and connected to one of the DVI outputs on the GefenPRO 16x16 DVI Matrix before applying power. By default, the Local EDID is read from the connected monitor and is copied to all 16 DVI inputs once the Matrix has been turned on. If a monitor is not detected by the Matrix at power-on, a default (internal) EDID of 640x480 will be used. This functionality can be disabled using the Secure Local EDID function through IP control. See page 21 for more information.
- There is no internal scaling in the GefenPRO 16x16 DVI Matrix. Each monitor attached to the Matrix must be able to display the resolutions output by the source device(s). For maximum compatibility it is recommended that only one common resolution be used by each source device.
- Advanced EDID features and IP configuration features are accessible through the RS-232 serial command set.
- Routing and EDID features can be managed using the built-in IP control feature.
- **IMPORTANT:** If the unit is installed in a closed or multi-rack assembly, do not block the ventilation holes of the enclosure.

FEATURES

Features

- Increases productivity
- Supports resolutions up to 1920x1200
- Front panel control buttons for local switching
- IP Control
- Serial RS-232 interface for remote control via a computer or control automation devices
- Discrete IR remote control
- Advanced EDID management permits uploading of custom internal or external EDID settings
- Supports DDWG standards for DVI
- Internal power supply
- Output masking command
- Standby mode
- Grounding pin
- IR Sensor
- IR Extender
- Power On/Off switch
- Status LCD (shows routing status)
- Rack mountable

Package Includes

- (1) GefenPRO 16x16 DVI Matrix
- (16) 6-foot DVI cable (M-M)
- (1) IR remote control unit
- (1) AC Power Cord
- (1) User Manual

PANEL LAYOUT

Front Panel



PANEL DESCRIPTION

Front Panel

1 **Control Buttons**

These buttons are used to navigate the LCD menu system. See pages 7 and 8 for more information.

- ◀ - Left
- ▶ - Right
- Select - Select

2 **Cancel Button**

This button is used to cancel a routing change in progress.

3 **IR Window**

Receives signals from the IR Remote Control unit.

4 **Power Indicator**

This LED indicator will glow red when the power is turned on.

5 **Power Switch**

Turn the power on or off using this switch.

6 **LCD Display**

Displays the current routing status of the Matrix and is also used to manage source routing.

PANEL LAYOUT

Back Panel

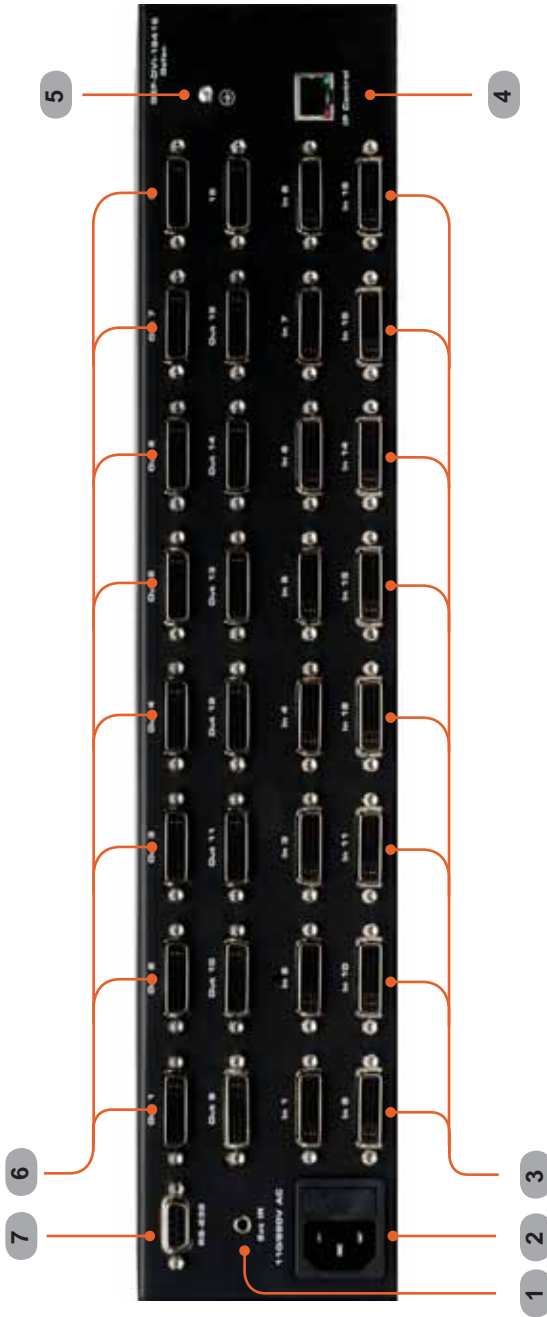

PANEL DESCRIPTIONS

Back Panel

- 1 IR Extender Port**
Connect an IR extender cable to this port.
- 2 110 / 220 V AC (50/60 Hz) Power Cable Receptacle**
Connect the included AC power cord from this receptacle to an available electrical outlet.
- 3 DVI Input Ports (1 - 16)**
Connect DVI source devices to these ports.
- 4 IP Control Interface**
Connect to this port to control the 16x16 DVI Matrix using IP Control. See page 26 for more information.
- 5 Grounding Terminal**
Provides a discharge path to ground in case a short circuit occurs between the “hot” lead of the power supply and the enclosure of the Matrix. The grounding wire should be attached from the grounding terminal to an approved ground path.
- 6 DVI Output Ports (1 - 16)**
Connect DVI monitors to these ports.
- 7 RS-232 Serial Port**
Connects to the RS-232 control device. The 16x16 DVI Matrix may be switched remotely using this port. See page 24 for more information.

CONNECTING AND OPERATING THE GEFENPRO 16X16 DVI MATRIX

How to Connect the GefenPRO 16x16 DVI Matrix

1. Connect up to 16 DVI source devices to the DVI inputs on the rear panel of the GefenPRO 16x16 DVI Matrix using the supplied DVI cables.
2. Connect up to 16 DVI monitor to the DVI outputs on the rear panel of the GefenPRO 16x16 DVI Matrix with user-supplied DVI cables.
3. Connect the included AC power cable to the power receptacle on the rear panel of the GefenPRO 16x16 DVI Matrix. Connect the opposite end of the cable into an available electrical outlet.
4. Power on the monitors and the source devices. Turn on the GefenPRO 16x16 DVI Matrix by pressing the power switch on the front panel.

How to Operate the GefenPRO 16x16 DVI Matrix

The GefenPRO 16x16 DVI Matrix offers a number of control options. The following methods can be used to control basic routing functions of the GefenPRO 16x16 DVI Matrix:

1. Front Panel Control Buttons - Pages 9 and 10
2. IR Remote Control - Pages 11 - 13
3. RS-232 Serial Control - Pages 15 - 30
4. IP Control - Pages 31 - 38

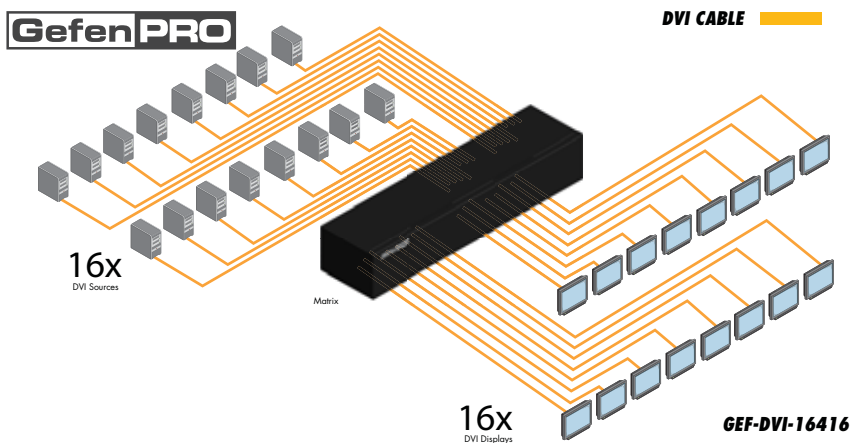

Attention: This product should always be connected to a grounded electrical socket.

FRONT PANEL DISPLAY

MAIN DISPLAY

The **Main Display** of the GefenPRO 16x16 DVI Matrix is a 16 character 2 line display. This display will show the standby screen and will also be used to aid in performing routing commands. When the unit is powered on, the following screen is displayed:



EDID LOADING
PLEASE WAIT

After a few moments, the Standby Screen is displayed. The Standby Screen is shown below:



GEFEN
16X16 DVI MATRIX

Displaying the Firmware Version

Pressing the ◀ button on the front panel will display the current firmware version:



MATRIX FIRMWARE
4.10

Displaying the Bootloader Version

Press the ◀ button to display the bootloader version:



BOOT LOADER
1.5

Press the ◀ button once more to return to the Standby Screen.

NOTE: The Cancel button can be pressed at any time to return to the Standby Screen.

FRONT PANEL DISPLAY

Displaying the Routing Status

From the main screen, press the **Select** button. When the arrow cursor is next to OUTPUT, pressing the ◀ or ▶ buttons on the front panel will show the current routing state of each input and output. The illustration below shows the routing state of output 1.



```
>OUTPUT: 01
INPUT : 01
```

Pressing the ▶ button again will display the routing state of output 2 and so on.

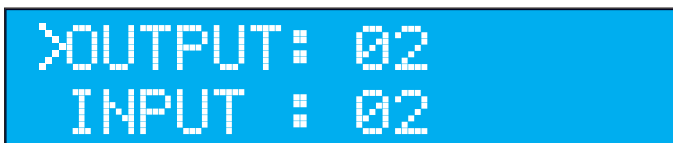

```
>OUTPUT: 02
INPUT : 02
```

Note that the number displayed next to INPUT may be different than the illustration above, depending upon the current routing state.

Routing Sources

Example:

Route the source device connected to In 2 to the monitor connected to Out 1.

1. From the Standby Screen, press the **Select** button on the front panel to display the routing status screen.
2. Press the **Select** button again to move the cursor to INPUT.
3. Press the ▶ button to set the source to Input 2. The source device connected to In 2 is now routed to the monitor connected to Out 1.

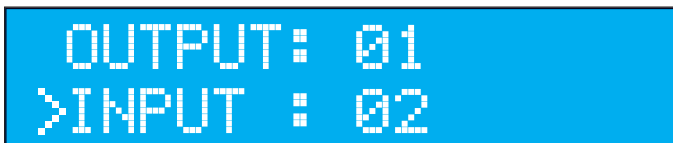

```
OUTPUT: 01
>INPUT : 02
```

4. Press the **Cancel** button to return to the standby screen.

NOTE: The **Cancel** button can be used to return to the standby screen at any time.

IR REMOTE DESCRIPTION

RMT-16416IR Remote Control Unit



1 **Activity Indicator**

This LED will be activated momentarily each time a button is pressed.

2 **Display and Source Selection Buttons**

These buttons are used to select which source is routed to a monitor.

Routing Sources using the Remote Control unit

Issuing a routing command is a two step process. The first step is to select the monitor (1-16) to which the source will be routed. The second step is to select the source (1-16).

Example:

Route the source device connected to In 6 to the monitor connected to Out 4.

1. Press button 4 (Out 4) on the IR remote control unit.
2. Press button 6 (In 6) on the IR remote control unit.

The source connected to In 6 will be routed to the monitor connected to Out 4.

IR REMOTE INSTALLATION

Installing the RMT-16416IR Battery

1. Remove the battery cover on the back of the IR Remote Control unit.
2. Insert the included battery into the open battery slot. The positive (+) side of the battery should be facing up.
3. Replace the battery cover.

The Remote Control unit ships with two batteries. One battery is required for operation and the other battery is a spare.



Battery Slot



CAUTION: Risk of explosion if battery is replaced by an incorrect type. Dispose of used batteries according to the instructions.

IR REMOTE CONFIGURATION

How to Resolve IR Code Conflicts

In the event that IR commands from other remote controls interfere with the supplied IR Remote Control unit, changing the IR Remote Control's IR channel will fix the problem. The IR Remote Control unit has a bank of DIP switches used for setting the IR channel.

The DIP switch bank is located underneath the battery cover.

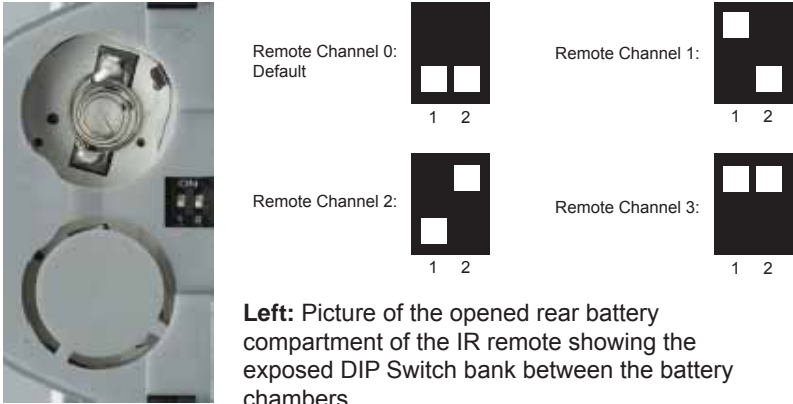

It is important that the IR channel on the Remote Control unit, matches the IR channel set on the GefenPRO 16x16 DVI Matrix. For example, if both DIP switches on the IR Remote Control unit are set to IR channel 0 (both DIP switches down), then the GefenPRO 16x16 DVI Matrix must also be set to IR channel 0. See page 25 on how to change the IR channel on the GefenPRO 16x16 DVI Matrix.

EDID. What is it and what is it used for?

Under normal circumstances, a source device (digital and analog) will require information about a connected device/display to assess what resolutions and features are available. The source can then tailor its output to send only resolutions and features that are compatible with the attached device/display. This information is called EDID (Extended Display Information Data) and a source device can only accept and read one EDID from a connected device/display. Likewise, the source can only output one resolution for use by a connected device/display.

Why is EDID so important with the GefenPRO 16x16 DVI Matrix?

The GefenPRO 16x16 DVI Matrix is a complex piece of technology that replicates and switches between multiple inputs and outputs. Each connected source device will require one EDID to read. EDID management is carefully handled by the GefenPRO 16x16 DVI Matrix to provide a single EDID for each source to read.

What options do I have to manage the EDID in the GefenPRO 16x16 DVI Matrix?

First, it is important to note that each source device can only output one video/audio signal type. This includes resolutions and timings. When multiple devices/displays are used, such as with the GefenPRO 16x16 DVI Matrix, it is important to use devices/displays that have similar or compatible resolutions and features. This will ensure that the single video/audio signal produced by the source device is accepted by all of the connected output devices/displays.

The user has the option, through utilization of the RS-232 serial interface, to choose how the unit will manage the EDID from multiple DVI devices/displays. Therefore the user has some control over the resolutions and features that the source devices will output. The GefenPRO 16x16 DVI Matrix has a LOCAL EDID management mode that will control how the EDID information is handled.

How do I change EDID modes in the GefenPRO 16x16 DVI Matrix?

EDID modes and IP configuration is managed via the RS-232 serial communications port. See page 13 for more information on the RS-232 serial communication features.

RS-232 SERIAL CONTROL INTERFACE

What features are available via the RS-232 serial communications port?

The GefenPRO 16x16 DVI Matrix can accept commands through the RS-232 serial communications port located on the rear panel. The current RS-232 control features are:

- Switching/routing of inputs to outputs without the IR remote control.
- Managing the EDID bank and EDID that is loaded into the LOCAL EDID.
- Upload new EDID's to the EDID bank or directly to the LOCAL EDID location.
- Manage IP settings.

How do I use these features?

These features were initially intended for utilization by custom installers in automated setups. However, these features can be tested and used by using any Windows PC with a terminal program.

What pins are used for communication with the GefenPRO 16x16 DVI Matrix?

Only pins 2 (Receive), 3 (Transmit), and 5 (Ground) are used for communication. A null-modem adapter should not be used with this product.

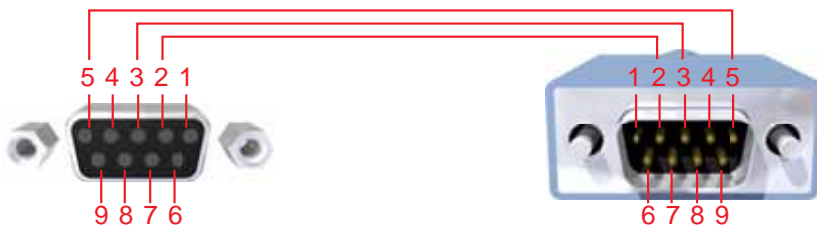

Only Pins 2 (RX), 3 (TX), and 5 (Ground) are used on the RS-232 serial interface

RS-232 Settings

Bits per second	19200
Data bits	8
Parity	None
Stop bits	1
Flow Control	None

RS-232 SERIAL CONTROL COMMANDS

RS-232 Features

RS-232 remote functions are used to control of this product's features. Features include input to output routing, EDID storage, EDID management, etc.

Functions Syntax

The syntax for each function is always the same:

#Character as the start flag → Function name → Space (_) as function name end flag → Parameter 1 → Space (_) → Parameter n → Carriage Return (\r)

Sample:

#FunctionName_param1_param2_param3_param4...\r

Syntax is NOT case sensitive.

Commands

Simplified syntax was used for command implementation for faster operation with the device: # character – isn't needed, the command name is reduced to 1 letter. The commands are not case-sensitive.

Command	Description
<i>R</i>	Routing command
<i>S</i>	Routes a single input to all outputs
<i>M</i>	Returns the current routing status of matrix
<i>F</i>	Toggle 5V fiber optic extender feature

R Command

The R command allows specific routing of inputs and outputs.

Syntax:

r param1 param2

Parameters:

<i>param1</i>	DVI Output	[1 - 16]
<i>param2</i>	DVI Input	[1 - 16]

S Command

The S command routes a single input to all 16 DVI outputs.

Syntax:

s param1

Parameters:

param1 Input [0 - 16]

Notes:

Setting *param1* to a value of 0 will place the matrix in *one-to-one mode*. This means that Input1 will be routed to Output1, Input2 will be routed to Output2, and so on.

M Command

The M command displays the current routing status of the matrix.

Syntax:

m

Parameters:

None

F Command

The F command returns the state of pin 14 of the DVI inputs.

Syntax:

f

Parameters:

None

Notes:

“High” is returned if +5V is enabled on the DVI input. “Low” is returned if +5V is disabled on the DVI input.

Using parameters with the F Command

Permits disabling / enabling of +5V for Fiber Optic Extenders.

Syntax:

f param1 param2

Parameters:

param1 DVI input [1 - 16]

param2 State [0 - 1]

Value	Meaning
0	Disable
1	Enable

Notes:

Setting *param1* to a value of 0 will apply the value of *param2* to all inputs.

RS-232 SERIAL CONTROL COMMANDS

EDID Management

Function	Description
#EDIDDSTOLO	Read downstream EDID and stores into a Local EDID
#EDIDDSTOBA	Read downstream EDID and stores in EDID Bank
#EDIDBATOLO	Read stored EDID from bank and stores in any Local Input
#EDIDDETOLO	Stores the default EDID in any input Local EDID
#LOEDIDTOLO	Load EDID file using serial port to one of the local memories
#PRLOEDID	Prints the Local EDID
#PRDSEDID	Read downstream EDID and sends to serial port
#PRBAEDID	Read EDID from bank and sends to serial port
#PREDIDST	Print EDID from stored Local banks.
#LOCKEDID	Secures the Local EDID

#EDIDDSTOLO Function

The #EDIDDSTOLO function reads the downstream EDID and stores it to a Local EDID.

Syntax:

```
#EDIDDSTOLO param1 param2 param3...param9
```

Parameters:

<i>param1</i>	A downstream display	[1 - 16]
<i>param2</i>	Input list	[0 - 16]
<i>param3 - 9 (optional)</i>	Input list	[1 - 16]

Notes:

By specifying zero as the second parameter, the downstream EDID is stored to all 16 DVI inputs. If more than eight inputs need to be specified in order to receive the downstream EDID, the #EDIDSDTOLO function must be executed twice:

Example:

```
#EDIDDSTOLO 2 1 2 3 4 5 6 7 8 9 10 11    not permitted!
```

Instead, this function must be run twice:

```
#EDIDDSTOLO 2 1 2 3 4 5 6 7 8            max 8 inputs!  
#EDIDDSTOLO 2 9 10 11                    remaining inputs
```

RS-232 SERIAL CONTROL COMMANDS

#EDIDSTOBA Function

The #EDIDSTOBA function reads the downstream EDID and stores it to a specified EDID bank.

Syntax:

```
#EDIDSTOBA param1 param2
```

Parameters:

<i>param1</i>	A downstream display	[1 - 16]
<i>param2</i>	EDID bank offset	[1 - 5]

#EDIDBATOLO Function

The #EDIDBATOLO function reads an EDID from an EDID bank and stores it to any local input.

Syntax:

```
#EDIDBATOLO param1 param2 param3...param9
```

Parameters:

<i>param1</i>	EDID bank offset	[1 - 5]
<i>param2</i>	Input list	[0 - 16]
<i>param3 - 9 (optional)</i>	Input list	[1 - 16]

Notes:

By specifying zero as the second parameter, the EDID in the specified bank is copied to all sixteen inputs. If more than eight inputs need to be specified in order to receive the EDID in the specified bank, the #EDIDBATOLO function must be executed twice.

Example:

```
#EDIDBATOLO 5 2 3 4 5 6 7 8 9 10 11 12 not permitted!
```

Function must be run twice:

```
#EDIDBATOLO 5 2 3 4 5 6 7 8 9 max 8 inputs  
#EDIDBATOLO 5 10 11 12 remaining inputs
```

RS-232 SERIAL CONTROL COMMANDS

#EDIDDETOLO Function

The #EDIDDETOLO function stores the Default EDID in any Local EDID.

Syntax:

```
#EDIDDETOLO param1 param2 param3...param9
```

Parameters:

<i>param1</i>	Input list	[0 - 16]
<i>param2 - 9 (optional)</i>	Input list	[1 - 16]

Notes:

By specifying 0 for *param1*, all inputs will receive the Default EDID or use *param1* - *param9* to specify individual local inputs which will receive the Default EDID.

#LOEDIDTOLO Function

The #LOEDIDTOLO function loads the specified EDID file to a specified local input via RS-232.

Syntax:

```
#LOEDIDTOLO param1 param2 param3
```

Parameters:

<i>param1</i>	Input	[1 - 16]
<i>param2</i>	EDID size	[1 - 2]

Value	Meaning
1	128 byte EDID
2	256 byte EDID

<i>param3</i>	eco	[0 - 1]
---------------	-----	---------

Notes:

Set *param1* to a value of 0 in order to specify all inputs. When using HyperTerminal, *param3* must be set to 1. Otherwise, set *param3* to 0.

#PRDSEDID Function

The #PRDSEDID function reads the downstream EDID and sends it to the serial port.

Syntax:

```
#PRDSEDID param1
```

Parameters:

<i>param1</i>	A downstream display	[1 - 16]
---------------	----------------------	----------

#PRLOEDID Function

The #PRLOEDID function reads the local EDID of a specified input and spools it to the serial port.

Syntax:

```
#PRLOEDID param1
```

Parameters:

<i>param1</i>	Input	[1 - 16]
---------------	-------	----------

#PRBAEDID Function

The #PRBAEDID function reads the EDID file from the specified bank and sends it to the serial port.

Syntax:

```
#PRBAEDID param1
```

Parameters:

<i>param1</i>	Bank	[1 - 5]
---------------	------	---------

#PREDIDST Function

The #PREDIDST function prints a table that contains details relating to the Local EDID source and the display name.

Syntax:

#PREDIDST

Parameters:

None

#LOCKEDID Function

The #LOCKEDID function secures the Local EDID and disables the automatic loading after power-up.

Syntax:

#LOCKEDID param1

Parameters:

param1

EDID lock state

[0 - 1]

Value	Meaning
0	Disable
1	Enable

IP Configuration

Function	Description
#SIPADD	Specifies a new IP address
#SNETMASK	Specifies a new net mask
#SGATEWAY	Specifies the new gateway
#SPORT	Specifies a new port
#PRWEBADD	Displays IP configuration and release details
#RSTIP	Sets default IP configuration

#SIPADD Function

The #SIPADD function specifies a new IP address.

Syntax:

```
#SIPADD param1 param2 param3 param4
```

Parameters:

<i>param1</i>	IP address	[0 - 255]
<i>param2</i>	IP address	[0 - 255]
<i>param3</i>	IP address	[0 - 255]
<i>param4</i>	IP address	[0 - 255]

Notes:

A reboot is required after using this function.

#SNETMASK Function

The #SNETMASK function specifies a new net mask.

Syntax:

```
#SNETMASK param1 param2 param3 param4
```

Parameters:

<i>param1</i>	IP address	[0 - 255]
<i>param2</i>	IP address	[0 - 255]
<i>param3</i>	IP address	[0 - 255]
<i>param4</i>	IP address	[0 - 255]

Notes:

A reboot is required after using this function.

#SGATEWAY Function

Specifies the new IP gateway.

Syntax:

```
#SGATEWAY param1 param2 param3 param4
```

Parameters:

<i>param1</i>	Gateway address	[0 - 255]
<i>param2</i>	Gateway address	[0 - 255]
<i>param3</i>	Gateway address	[0 - 255]
<i>param4</i>	Gateway address	[0 - 255]

Notes:

A reboot is required after using this function.

#SPORT Function

Specifies a new port.

Syntax:

```
#SPORT param1
```

Parameters:

<i>param1</i>	Port	[0 - 255]
---------------	------	-----------

Notes:

A reboot is required after using this function.

#PRWEBADD Function

Prints the current IP configuration on the screen.

Syntax:

```
#PRWEBADD
```

Parameters:

None

#RSTIP Function

Sets IP configuration to default.

Syntax:

```
#RSTIP
```

Parameters:

None

Notes:

This command requires the unit to be rebooted in order to take effect.

General Functions

Function	Description
#ACTIVEBOLO	Enables the boot loader
#FADEFAULT	Reset Matrix to default settings
#LOCKPOWER	Toggles the lock power state
#MASKOUT	Blanks selected outputs
#MEMERASE	Sets local and IP configurations to default settings
#RMTIRADD	Set the remote IR channel
#STBYMODE	Set system to Standby Mode

#ACTIVEBOLO Function

The #ACTIVEBOLO function enables the boot loader.

Syntax:

#ACTIVEBOLO

Parameters:

None

Notes:

This command must be typed twice in order to activate the boot loader.

#FADEFAULT Function

The #FADEFAULT function will erase all local memory EDID banks, reset default routing, and clear all IP settings.

Syntax:

#FADEFAULT

Parameters:

None

#LOCKPOWER Function

The #LOCKPOWER enables/disables the power lock state. Enabling this feature will store the 5V status for each input prior to shutting the unit down. This preserves the 5V state when the unit is restarted.

Syntax:

#LOCKPOWER param1

Parameters:

param1 State [0 - 1]

Value	Meaning
0	Disable Power Lock
1	Enable Power Lock

#MASKOUT Function

The #MASKOUT function allows blanking of selected outputs.

Syntax:

#MASKOUT param1 param2

Parameters:

param1 Output [1 - 16]

param2 Masking state [0 - 1]

Value	Meaning
0	Unmask
1	Mask

Notes:

The current masking state will be lost if the unit is rebooted or power is lost.

RS-232 SERIAL CONTROL COMMANDS

#MEMERASE Function

The #MEMERASE function sets the local and IP configurations to the default settings.

Syntax:

#MEMERASE

Parameters:

None

#RMTIRADD Function

The #RMTIRADD function sets the IR channel for the Matrix.

Syntax:

#RMTIRADD param1

Parameters:

param1

IR channel

[0 - 3]

Value	Meaning
0	IR channel 1
1	IR channel 2
2	IR channel 3
3	IR channel 4

#STBYMODE Function

The #STBYMODE places the Matrix in stand-by mode. Stand-by mode reduces power consumption.

Syntax:

#STBYMODE param1

Parameters:

param1

State [0 - 1]

Value	Meaning
0	Disable stand-by mode
1	Enable stand-by mode

IP CONTROL

The GefenPRO 16x16 DVI Matrix supports IP-based control using an integrated Web interface. To access this feature, an IP address, subnet, gateway, and port number need to be set on the GefenPRO 16x16 DVI Matrix (**Default IP: 192.168.0.70 Subnet: 255.255.255.0 Gateway: 192.168.0.1 Port: 80**). Consult the network administrator to obtain the proper IP address and settings for this product to properly communicate on the network.

The IP control setting can be configured via the RS-232 control interface. Once this has been accomplished, access to the Web Interface is possible.

Simply type the IP address that was assigned to the product in a web browser to access the **Main Page**. It should look like the image below.



MAIN PAGE

The **Main Page** will display the current status and can also be used to create routes.

To create a new route, follow the steps below:

1. Select which outputs will display the source by clicking on each check box.
2. Select the radio button of the input that will be routed to each output.
3. Click the SWITCH button to update the new routing configuration.

This page will automatically refresh every minute. However, at anytime the "Refresh" button can be pressed to refresh the status of the Matrix.

MANAGE EDID



The **Manage EDID** page is used to see the status of the EDID saved in the local storage location for each input. This section has additional tabs for advanced EDID functions. These tabs are:

- SET INPUT TO DEFAULT EDID
- UPLOAD EDID (Future Implementation)
- DOWNLOAD EDID (Future Implementation)
- COPY EDID
- EDID LOCK STATE

This page will automatically refresh every minute. However, at anytime the REFRESH button can be pressed to return the current status of the Matrix.

SET INPUT TO DEFAULT EDID

Pressing the SET INPUT TO DEFAULT EDID button will display additional options. The following page will open.



On this page, local memory locations can be selected to receive the built-in EDID stored in the GefenPRO 16x16 DVI Matrix. To set an input's local memory location to the default EDID follow the steps below.

1. Select any number of inputs by clicking on the desired checkboxes.
2. Click on the **Set Default EDID** button to update the change(s).

Note: After this command is complete the Web Interface will return to the VIEW MATRIX STATUS page.

This page will automatically refresh every minute. However, the REFRESH button can be pressed at any time to return the current status of the Matrix.

COPY EDID

Pressing the COPY EDID button will display additional options. The following page will open.



On this page, the user can select an EDID from either the local memory locations (Input) or from a monitor that is currently attached to any output and copy that EDID to any other LOCAL memory location. This will permit control of what EDID information will be passed to each source connected to the GefenPRO 16x16 DVI Matrix.

To copy an EDID follow the steps below.

1. Select an EDID from the **Select Source to Copy from** section. An EDID can be selected from a monitor connected to one of the outputs or from an EDID already loaded into one of the local memory locations (Input). It should be noted that only one EDID can be selected for copying.
2. Select the local memory locations that will receive the selected EDID under the **Select Input(s) to Copy to** section. Multiple local memory locations can be specified during this step.
3. Click on the **Set EDID** button to initiate the change(s).

This page will automatically refresh every minute. However, at anytime the **Refresh** button can be pressed to refresh the status of the Matrix.

NOTICE: UPLOAD EDID and DOWNLOAD EDID features are not supported at the time of this writing.

EDID LOCK STATE

The 16X16 DVI Matrix allows the Local EDID to be preserved after the unit has been powered off. Once enabled, this will function will prevent the 16X16 DVI Matrix from reading the EDID of a monitor, when the matrix is powered on.



The EDID Lock State can be enabled (ON) or disabled (OFF). The EDID Lock State is used.

1. Once the Local EDID has been stored, press the EDID LOCK STATE web button.
2. Select the ON radio button from the dialog and press Update EDID Lock State.

The 16X16 DVI Matrix can be powered-down and the Local EDID will be preserved. To disable the EDID LOCK STATE feature, select the OFF radio button in the Web interface and press the Update EDID Lock State button. Once the EDID LOCK STATE has been disabled (OFF), the 16X16 DVI Matrix will read and use the EDID of the monitor connected to the matrix.

MASKING



The **Masking** page is used to hide an output from displaying any video. From this page, all outputs can be set to “Active” or “Mask”. When an output is set to “Active”, it will function normally. When an output is set to “Mask”, it will not output any video. To set the “Active” or “Mask” mode, follow the steps below.

1. Select either “Active” or “Mask” for any number of desired outputs.
2. Press the “Submit” button to initiate the change(s).

After this command is complete the user will be returned to the **Main Page**.

This page will automatically refresh every minute, however, at anytime the “Refresh” button can be pressed to refresh the status of the matrix.

NOTE: All masked outputs will become active if the unit is power-cycled.

IP CONFIGURATION

Gefen® 16x16 DVI Manager

VIEW MATRIX STATUS MANAGE EDD MASKING **IP CONFIGURATION** BACKUP/RESTORE POWER MANAGEMENT

MAC Address	IP Address	Subnet	Gateway	Port
0:1C:91:1 0:1C	192.168.2.26	255.255.255.0	192.168.2.1	80

Refresh

Change IP Settings

IP Address: (default: 192.168.0.70)
Subnet: (default: 255.255.255.0)
Gateway: (default: 192.168.0.1)
Port: (default: 80)

Save

Reset IP Configuration to Defaults: [Reset]

The **IP Configuration** page is used to set the IP settings that will be used to access the Web interface. The following items can be configured from this menu.

- IP Address (Default: 192.168.0.70)
- Subnet (Default: 255.255.255.0)
- Gateway (192.168.0.1)
- Port (Default: 80)

To change these settings follow the steps below.

1. Enter the desired network information into the fields provided.
2. Press the “Save” button to initiate the change(s).

Note: After this command is complete the user will be returned to the **Main Page**. Setting made on this page will not take effect until the unit is restarted. Please disconnect power from the unit and reconnect power for changes to take effect.

At anytime, the “Reset” button can be pressed to return the IP settings to their defaults.

BACKUP/RESTORE



The **Backup/Restore** page is used to backup and restore complete setup configurations.

Note: This feature will be implemented in a future release.

POWER MANAGEMENT



The **Power Management** page is used to set optional +5V power on an input to power specific optional devices. The current status of this feature for each input can be viewed on this page. To set this feature for each input follow the steps below.

1. Select the +5V option, either "On" or "Off" for each desired input.
2. Click on the "Update" button to initiate the change(s).

Note: After this command is complete the user will be returned to the **Main Page**.

This page will automatically refresh every minute, however, at anytime the "Refresh" button can be pressed to refresh the status of the matrix.

FIRMWARE UPDATE

FIRMWARE UPDATE PROCEDURE

To Begin the update procedure the unit's Boot Loader must be activated. To activate the Boot Loader please follow the procedure below:

If the unit is already powered on, the following RS-232 command can be used to activate the Boot Loader:

1. Connect RS-232 cable to PC and activate the Hyper Terminal program.
2. Type the command: #ACTIVEBOLO\r
3. Re-type the command: #ACTIVEBOLO\r

If the unit is not powered on, follow the instructions below to activate the Boot Loader:

1. Connect RS-232 cable to PC and activate the Hyper Terminal program.
2. Make sure Hyperterminal is set to the following:
 - a. Baud rate = 19200
 - b. Stop bits = 1
 - c. Data bits = 8
 - d. Flow control = None
3. Press the following three buttons on the front panel of the 16x16 simultaneously, while powering-on the unit:
 - a. select
 - b. < (left cursor)
 - c. > (right cursor)

Once the Boot Loader is activated the following message should appear:

```
DVI16x16 Boot Loading
===== Main Menu =====
Download new program ----- 1
Cancel ----- 2
=====
```

FIRMWARE UPDATE

Follow the on-screen instructions to complete the firmware update process:

1. Press [1] on the computer keyboard to begin downloading program to the temporary memory.

2. A message will appear in Hyperterminal:

```
Waiting for the file to be sent ... (press 'a' to abort)
```

3. In Hyperterminal, click Transfer > Send File...

4. Click Browse... and select the .BIN file to be uploaded (e.g. DVI16X16_uIP_4_10.bin)

5. Select Ymodem for the protocol.

6. Press Send on the Send File dialog box.

7. A message will appear in Hyperterminal:

```
Programming Completed Successfully!
```

RACK MOUNT SAFETY INFORMATION

- a. Maximum recommended ambient temperature: 45 °C
- b. Increase the air flow to maintain the temperature inside the rack.
- c. Install the product evenly to avoid mechanical overload.
- d. Connect an earthing wire between the an earthing stud and the grounding pin on the chassis.

SPECIFICATIONS

Video Amplifier Bandwidth	165 MHz per channel
Single Link Range	1920x1200
Input Video Signal	1.2 Volts p-p
IR Extender.....	3.5 mm mini-stereo
RS-232 Interface.....	DB-9 serial, female
DVI Connector	DVI-I 29-pin, female (digital only)
Power Supply.....	100 ~ 240 V AC (x2 for redundancy)
Power Consumption	90 Watts (max.)
Operating Temperature.....	0 °C ~ 45 °C / 32 °F ~ 104 °F
Storage Temperature.....	-20 °C ~ 60 °C / -4 °F ~ 140 °F
Relative Humidity.....	20% ~ 90% RH (no condensation)
Dimensions	17.25" W x 3.5" H x 12" D
Rack-mountable	2U rack space, rack ears included
Shipping Weight	28.1 lbs.

WARRANTY

Gefen warrants the equipment it manufactures to be free from defects in material and workmanship.

If equipment fails because of such defects and Gefen is notified within two (2) years from the date of shipment, Gefen will, at its option, repair or replace the equipment, provided that the equipment has not been subjected to mechanical, electrical, or other abuse or modifications. Equipment that fails under conditions other than those covered will be repaired at the current price of parts and labor in effect at the time of repair. Such repairs are warranted for ninety (90) days from the day of reshipment to the Buyer.

This warranty is in lieu of all other warranties expressed or implied, including without limitation, any implied warranty or merchantability or fitness for any particular purpose, all of which are expressly disclaimed.

1. Proof of sale may be required in order to claim warranty.
2. Customers outside the US are responsible for shipping charges to and from Gefen.
3. Copper cables are limited to a 30 day warranty and cables must be in their original condition.

The information in this manual has been carefully checked and is believed to be accurate. However, Gefen assumes no responsibility for any inaccuracies that may be contained in this manual. In no event will Gefen be liable for direct, indirect, special, incidental, or consequential damages resulting from any defect or omission in this manual, even if advised of the possibility of such damages. The technical information contained herein regarding the features and specifications is subject to change without notice.

For the latest warranty coverage information, please visit Gefen's Warranty web page at <http://www.gefen.com/kvm/aboutus/warranty.jsp>

PRODUCT REGISTRATION

Please register your product online by visiting Gefen's web site at <http://www.gefen.com/kvm/Registry/Registration.jsp>

LICENSING

lwIP is licenced under the BSD licence:

Copyright (c) 2001-2004 Swedish Institute of Computer Science.
All rights reserved.

Redistribution and use in source and binary forms, with or without modification, are permitted provided that the following conditions are met:

1. Redistributions of source code must retain the above copyright notice, this list of conditions and the following disclaimer.
2. Redistributions in binary form must reproduce the above copyright notice, this list of conditions and the following disclaimer in the documentation and/or other materials provided with the distribution.
3. The name of the author may not be used to endorse or promote products derived from this software without specific prior written permission.

THIS SOFTWARE IS PROVIDED BY THE AUTHOR ``AS IS'' AND ANY EXPRESS OR IMPLIED WARRANTIES, INCLUDING, BUT NOT LIMITED TO, THE IMPLIED WARRANTIES OF MERCHANTABILITY AND FITNESS FOR A PARTICULAR PURPOSE ARE DISCLAIMED. IN NO EVENT SHALL THE AUTHOR BE LIABLE FOR ANY DIRECT, INDIRECT, INCIDENTAL, SPECIAL, EXEMPLARY, OR CONSEQUENTIAL DAMAGES (INCLUDING, BUT NOT LIMITED TO, PROCUREMENT OF SUBSTITUTE GOODS OR SERVICES; LOSS OF USE, DATA, OR PROFITS; OR BUSINESS INTERRUPTION) HOWEVER CAUSED AND ON ANY THEORY OF LIABILITY, WHETHER IN CONTRACT, STRICT LIABILITY, OR TORT (INCLUDING NEGLIGENCE OR OTHERWISE) ARISING IN ANY WAY OUT OF THE USE OF THIS SOFTWARE, EVEN IF ADVISED OF THE POSSIBILITY OF SUCH DAMAGE.



Rev C10
4.10

20600 Nordhoff St., Chatsworth CA 91311
1-800-545-6900 818-772-9100 fax: 818-772-9120
www.gefenpro.com support@gefenpro.com

