



Installation and Assembly -

Desktop Swivel Mount

For 26" to 47" Flat Panel TV's with VESA® 200 x 100 or 200 x 200 Mounting Hole Patterns

Models: HP447

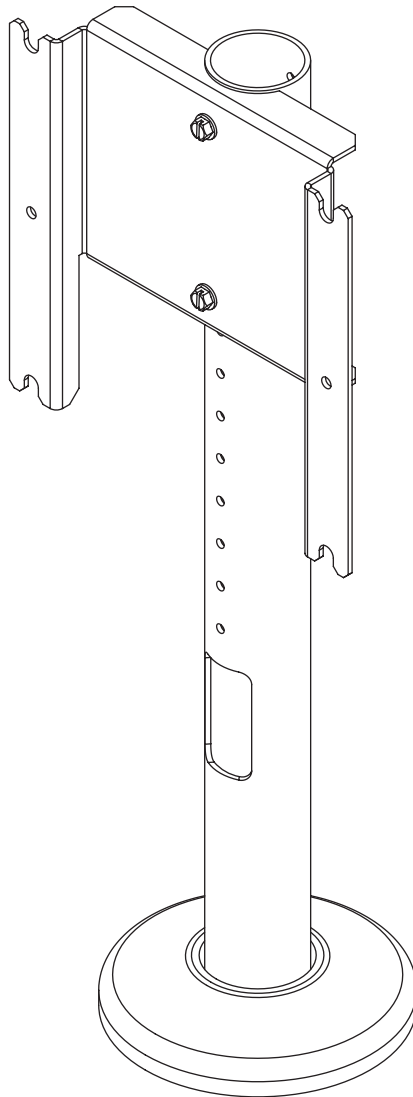

Max Load Capacity: 75 lb (34 kg)

NOTE: Read instruction sheet before you start installation and assembly.

Before you begin, make sure all parts shown are included with your product.

Parts List

Description	Qty.	Part #
A support tube	1	091-1036
B base backer plate	1	090-1544
C desktop swivel base	1	090-1821
D adapter plate	1	091-1030
F thrust washer	1	590-1287
G slope nuts	3	530-0035
H 1/4-20 x 3/4" hex head screw	2	520-1321
I M4 x 12 mm serrated socket pin screw	4	510-1079
J 4 mm allen wrench	1	560-9646
K 10-32 x 1/2" set screw	2	520-1614
L fender washer	4	540-1008
M 1/4-20 x 3" threaded rod	4	520-2585
N 1/4-20 lock nut	4	530-1021
O M6 x 12 mm socket pin screw	4	510-1050
P M8 x 15 mm socket pin screw	4	520-1068
Q #10 SAE flat washer	4	540-9400

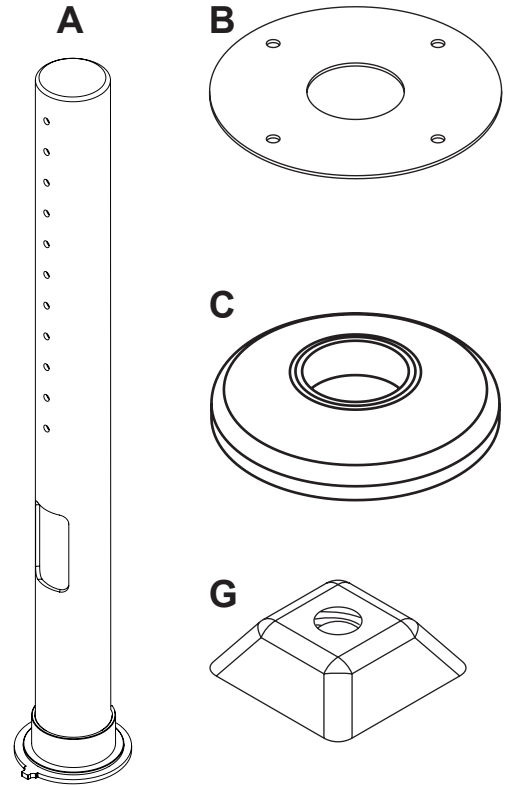

NOTE: Some parts may appear slightly different than illustrated.

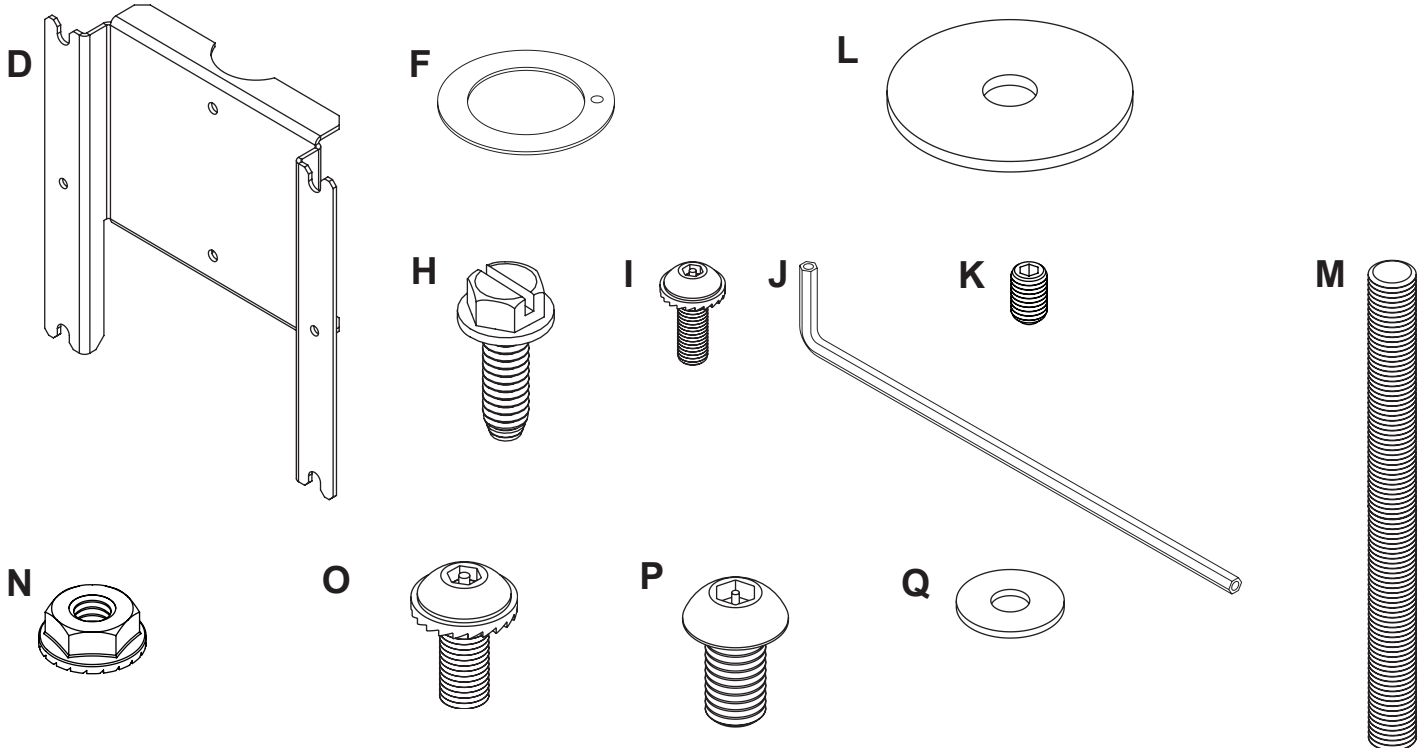

Tools Needed for Assembly

- drill
- 17/64" drill bit
- phillips screwdriver
- 3/32" allen wrench
- 5/8" open box wrench

- 1** Use base backer plate (**B**) as a template to mark location of holes. Drill four holes using a 17/64" drill bit in a square formation. In the center of the square formation drill 2" to 3" cord management hole.

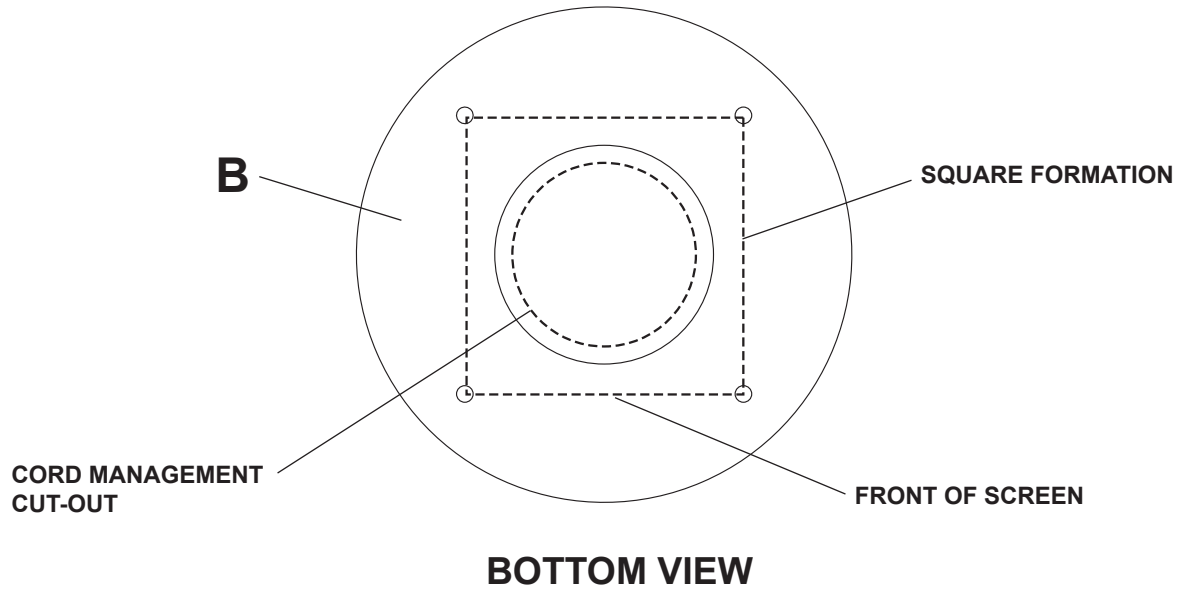

⚠ WARNING

- Wooden mounting surface requires a minimum of 3/4" thickness to hold screen securely.

- 2** Turn base (**C**) upside down and insert four threaded rods (**M**) into base (**C**), as shown below.

NOTE: Threaded rods must fasten a minimum of three turns.

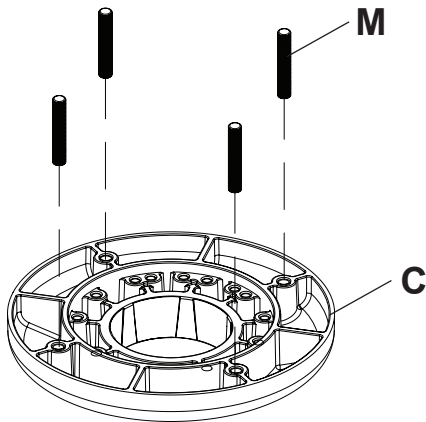

fig. 2.1

- 3** Turn base (**C**) upside down insert support tube (**A**), and thrust washer (**F**) as shown below.

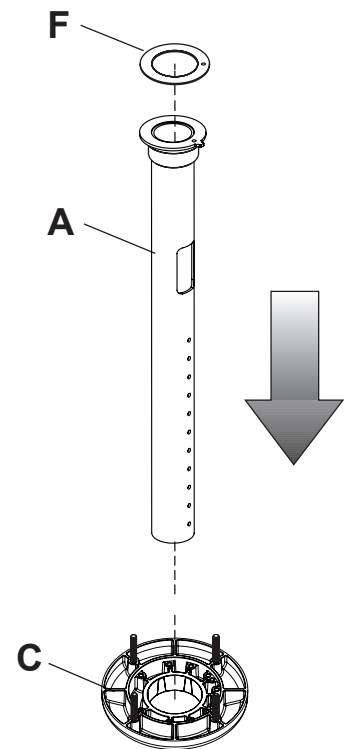

fig. 3.1

Swivel Restriction

- 4** Refer to fig. 4.1 and 4.2, select the desired swivel degree. Using a 3/32" allen wrench, fasten two set screws (**K**) where indicated below to the outside of desired angle in steel base (**C**).
NOTE: Set screws (**K**) must be bottomed out into base.

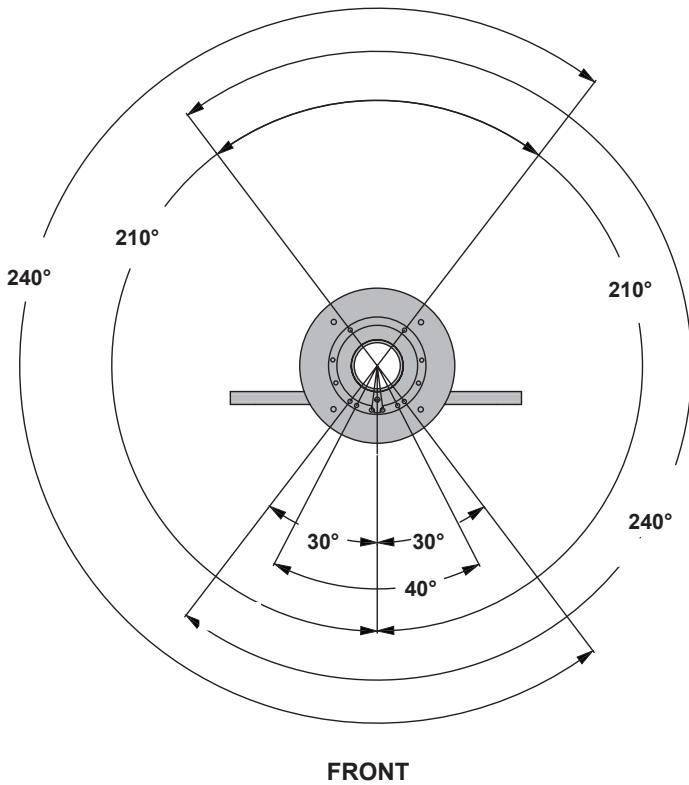

fig. 4.1

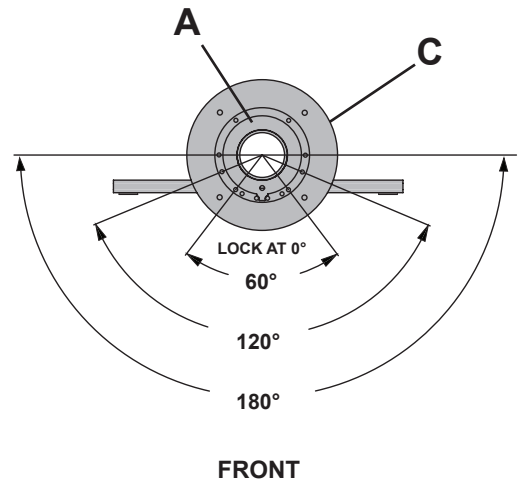

fig. 4.2

Mounting to Support Surface

⚠ WARNING

- Make sure that the supporting surface will safely support the combined load of the equipment and all attached hardware and components

CAUTION

- Installations to desktops that have a gap between two supporting boards are not acceptable mounting surfaces for the HP line of desktop swivel mounts.

Mounting using Non-Security.....Step 5 Page 5

Mounting using Security Slop Nuts (Optional)Step 7 Page 5

Mounting using Non-Security

- 5** Line up backer plate (B) with threaded rods (M).
NOTE: Washer (F) must be centered.

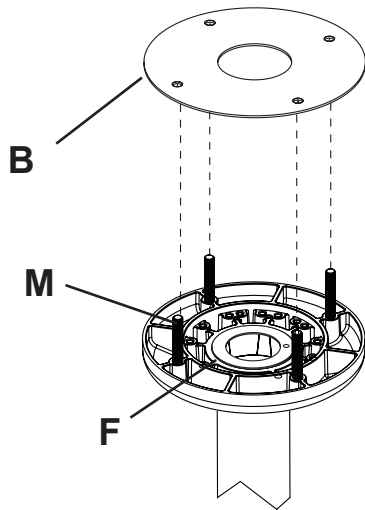

fig. 5.1

- 6** Tighten in sequenced pattern Using four fender washers (L) and four lock nuts (N) as shown in Figure 6.1. The 1/4-20 locknuts (N) should at least be flush with the bottom of the threaded rods (M). Line up base assembly (step 5), through supporting surface with pattern of base (C) facing the front as shown in Detail 1.

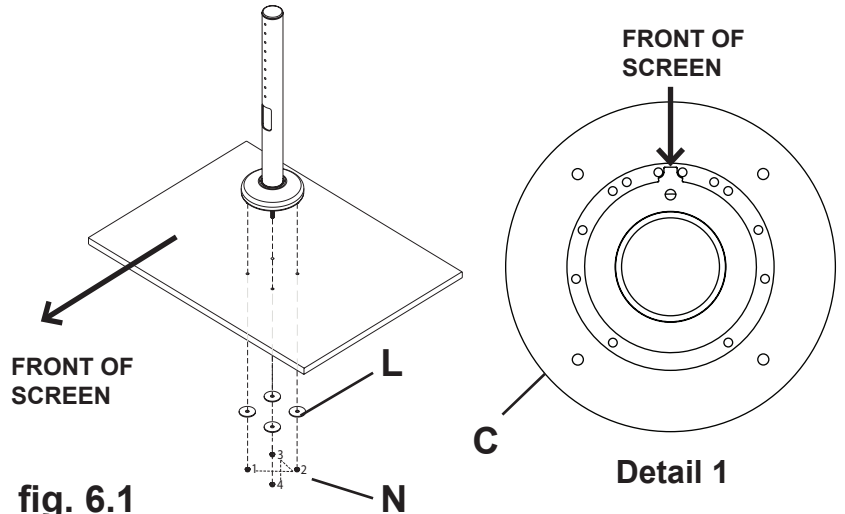

fig. 6.1

Mounting using Security Slope Nuts (Optional)

- 7** For added security replace two of the washers and locknuts with slope nuts.
 Hand tighten slope nuts (G) onto two of the thread rods (M) until snug against bottom of table as shown in Detail 2.

Thread another slope nut (G) upside-down, about two turns from first slope nut (G) as shown in Detail 3.

Insert a 5/8" open box wrench between both slope nuts (G) and tighten as shown in detail 4.

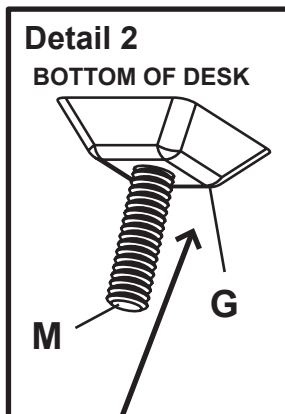

NOTE: Avoid jamming both slope nuts (G) together, doing so may make it difficult to remove slope nut used for tightening.
 After slope nut is secure remove bottom slope nut.

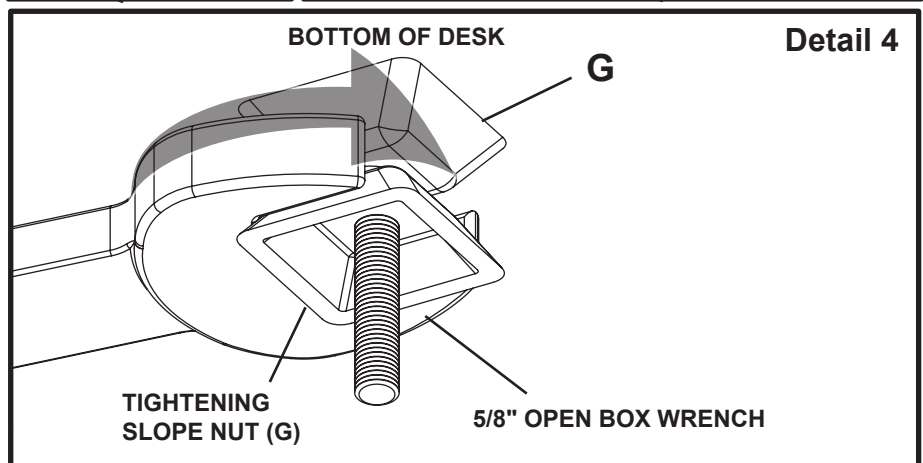
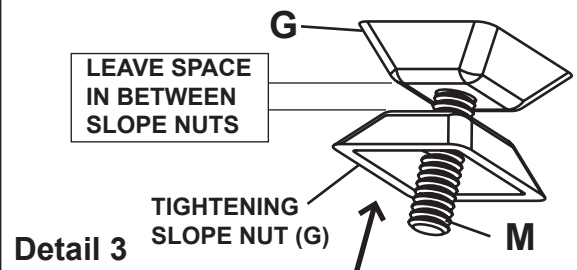

- 8** **NOTE:** Adapter plate support box (**D**) can be flipped either way to allow necessary screen clearance. For best results, have screen close to desktop but not touching. Adapter plate (**D**) is adjustable up to 7.87" (200 mm) " at .984" (25mm) increments. Attach adapter plate (**D**) to support tube (**A**) as shown. Fasten two 1/4-20 x 3/4" hex head screws (**H**) through adapter plate (**D**) and support tube (**A**), as shown.

SUPPORTING SURFACE NOT SHOWN FOR CLARITY

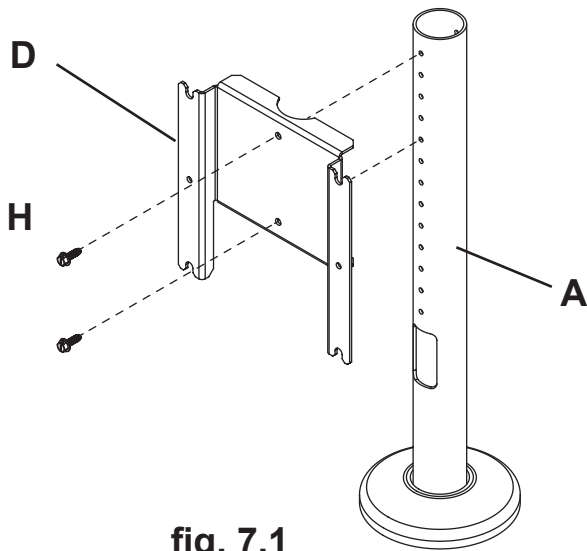

fig. 7.1

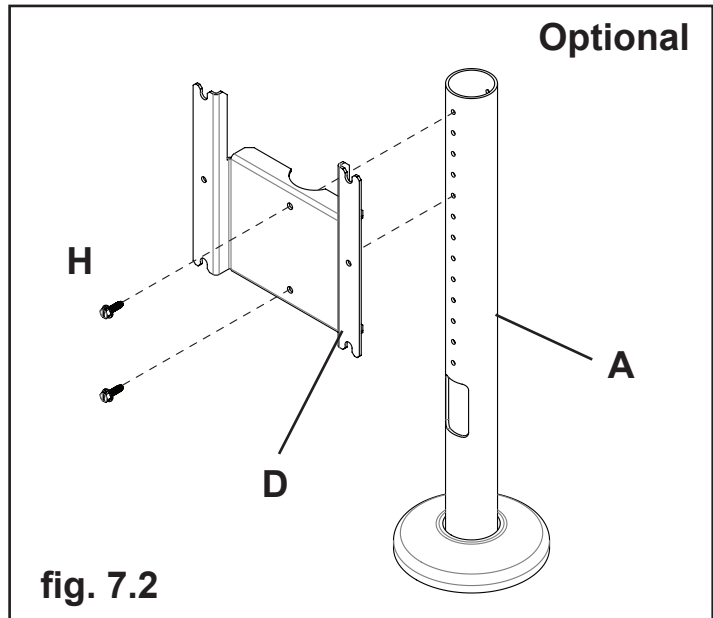

fig. 7.2

⚠ WARNING

- If screws don't get three complete turns in the screen inserts or if screws bottom out and bracket is still not tightly secured, damage may occur to screen or product may fail.

Mounting using 200 mm x 200 mm Hole Pattern

- 9** Fasten two socket pin screws (**I**, **O**, or **P**) into top mounting holes in back of screen leaving 1/8" of exposed thread as shown below. Hook exposed threads onto top of adapter plate (**D**) as secure using two socket pin screws (**I**, **O**, or **P**). **NOTE:** When using socket pin screw (**I**), #10 flat washers (**Q**) are required.

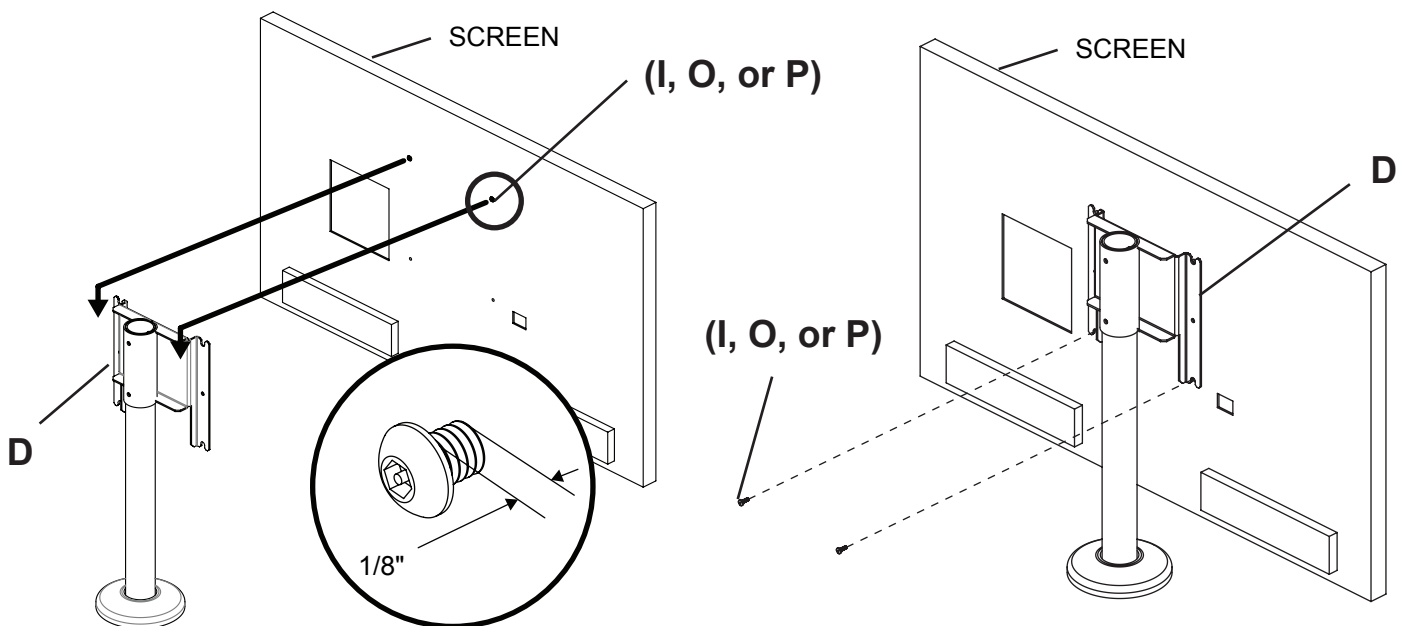

FOR SCREENS WITH VESA 200 X 200 PATTERN SHOWN

Mounting using 200 mm x 100 mm Hole Pattern

- 10** Fasten two socket pin screws (**I, O, or P**) into top mounting holes in back of screen leaving 1/8" of exposed thread as shown below. Hook exposed threads onto top of adapter plate (**D**) as secure using two socket pin screws (**I, O, or P**). **NOTE:** When using socket pin screw (**I**), #10 flat washers (**Q**) are required.

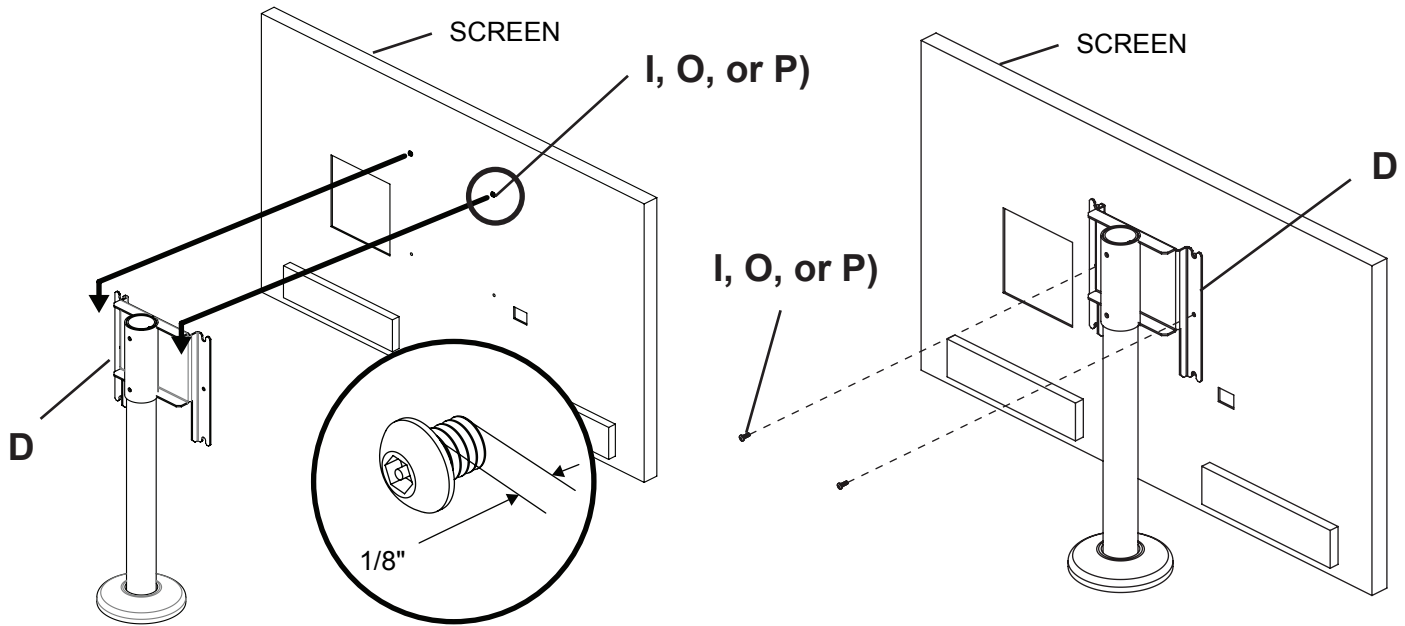

FOR SCREENS WITH VESA 200 X 100 PATTERN SHOWN