

Other Applicable Conference Products- Camera T-Bar

# HZ-D77H03-MP

## The camera mount for wall mounting



Matching High Speed Dome for wall mounting

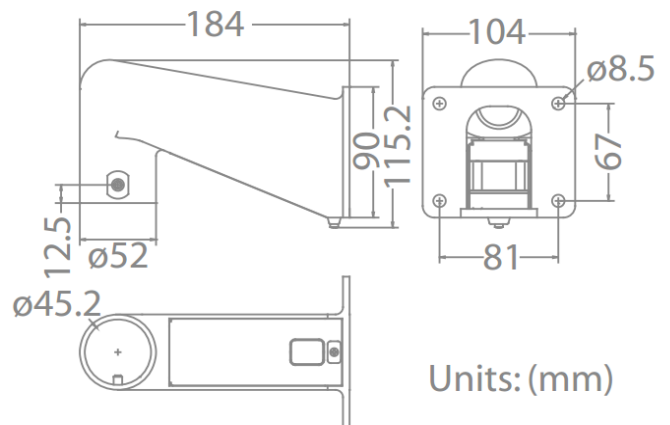

### TECHNICAL SPECIFICATIONS

Dimensions	184 × 104 × 115.2 mm (7.2 × 4.1 × 4.5 inches)
Diameter	45 mm (1.8 inches)
Weight	0.6 kg (1.3 lbs)