

DATA SHEET

16x16 Multicast supportable HDMI/DVI IPKVM Extender

IPKVM-310-ED

Contents

- ◆ Description
- ◆ Features
- ◆ Supporting Video Resolutions for Input / Output
- ◆ Applications
- ◆ Technical Specification
- ◆ EMC Test
- ◆ Connection Diagram
- ◆ Block Diagram

OPTICIS HQ

Headquarters

Opticis Co., Ltd.
16Fl, Kins Tower
8 Sungnam-daero, 331 beon-gil,
Bundang-gu,
Seongnam-si, Gyunggi-do, 463-844
South Korea
Te l: +82 (31) 719-8033
Fax: +82 (31) 719-8032

■ Description

The IPKVM Extender, IPKVM-310ED is designed for extending of HDMI video, keyboard and mouse. IPKVM-310ED, composed of pairs of transmitters and receivers, works in conjunction to provide unicast (1 to 1) or multicast (16 to 16) streaming over an IP network. The transmitter, IPKVM-310E (Encoder,Tx), connected to a HDMI PC source, encodes the video signal by H.264 and transmits the video signal via Ethernet. The receiver, IPKVM-310D (Decoder,Rx), connected to a display monitor, receives the H.264 encoded video signal via the Ethernet and decodes video signal for HDMI display. The USB keyboard and mouse interface in the remote receiver, IPKVM-310D, also can be accessed to the source via transmitter IPKVM-310E, if it is connected to the source by USB interface.

The IPKVM-310-ED supports the digital video data of full HD up to 1920x1080p at 60Hz and stereo audio and transmits the signal via Internet / Intra network. It also enables to distribute sixteen (16) video sources up to sixteen (16) displays in the multi-screen mode or the single-screen HD mode on the remote displays and makes sixteen (16) local keyboard and mouse accesses to the source. By using GUI interface and PC program, user can control the transmitters for connecting in the receiver side. With these key features, 16 x 16 IP routing system can be configured.

■ Features

- LAN standard: 802.3 Ethernet 10/100Mbps
- Video Resolution: up to 1920x1080p@60Hz
- Monitoring Mode: 640x480, 16CH Multi-screen
- HID KVM mode: 1920x1080, 1CH Single-screen with HID Keyboard/Mouse
- H.264 CODEC
- OSD GUI, Multi-screen mode / Single-screen HD mode supported
- Remote Manager: PC Program for User Setting & Control
- HDMI V1.3, DVI 1.0
- USB KVM via backchannel: USB HID mouse & keyboard on remote site (Rx) or local site (Tx)
- IPKVM-310E (Transmitter,Tx): Power Jack, RJ45, HDMI Input /HDMI Output (Loop-through) and mini USB port/Dual USB port
- IPKVM-310D (Receiver,Rx): Power Jack, RJ45, HDMI Output and Dual USB ports

■ **Supporting Video Resolutions for Input / Output (TBD)**

IPKVM-310ED supports 3 kinds of resolutions and you have to fix one of them for same EDID. So a group of Rxs and Txs must have same resolution to display videos of Txs on 16ch multi-screen of Rxs.

- 1280x720p60
- 1280x1024p60
- 1920x1080p60

Note: Some DVI resolutions may not be shown properly on the display. The image would be shifted to one side.

■ **Applications**

- Home AV
- KVM
- Video control room
- Digital signage
- Medical imaging

■ Technical Specification
 - General Specification

Item	Description	
Display mode	Multi-screen mode(16CH): VGA, 16CH simultaneously Monitoring mode	
	Single-screen HD mode(1CH):1920x1080, 1CH HID KVM mode	
Network(LAN)	10/100 Base-T Ethernet: TCP/IP based wired network with CAT5e/ CAT6 Cables	
Video Streaming protocol	RTSP, RTP, RTCP, UDP / TCPIP	
Video Codec	MPEG-4 Part 10/AVC (H.264)	
Resolution	Up to 1080p@60Hz	
Video Interface Standard	HDMI 1.3 and DVI1.0	
Tx Video Interface	Input: 1 HDMI/DVI Input Output: 1 HDMI/DVI Output (Loop-Through)	
Rx Video Interface	Output: 1 HDMI/DVI Output	
Keyboard/Mouse (Tx)	1x mini USB B type to PC	2x USB A type (for Local HID Keyboard/Mouse)
Keyboard /Mouse (Rx)	2x USB USB A type (for Remote HID Keyboard/Mouse)	
LAN Port	RJ-45 (Tx/Rx 1 port)	
RS232 Port	3 Pin Terminal Block for Knob & alarm interface	
Digital I/O Port	Terminal Block for Console Switch & Console Indicator	
3 Stage Slide Switch(Tx)	Local/Remote/Console for Control Authority	
Reset Switch	SW reset & Factory reset	
External Console Switch (Tx, Optional)	When 3-State Slide Switch set with console, you can select Local/Remote authority on the switch pad externally.	
External Console Indicator (Rx, Optional)	When 3-State Slide Switch set with console, you can check Local/Remote authority on the pad externally with LED status.	
Configuration access	OSD GUI via Mouse/Keyboard	
	PC Program (Remote Manager) for user account, device setting, status monitoring	
EDID	Built-in EDID & EDID Read/Write	
Dimension	Tx: 112x28x104mm (WHD), Rx: 112x28x104mm (WHD)	
Power	100-240VAC, 50-60Hz	
	5V 3A Adaptor	
Power Consumption	Transmitter <10W	Receiver <10W
Operating Temperature	0~50°C	
Storage Temperature	-30~70°C	
Certification	FCC, CE	

- Electrical Characteristics

	Parameter	Symbol	Minimum	Typical	Maximum	Units	
Power Supply	Supply Voltage, Temp 25°C	VCC	+ 4.75	+ 5.0	+ 5.25	V	
	Supply Current	Tx	ITCC	-	2	-	A
		Rx	IRCC	-	2	-	A
	Power Dissipation	Tx	PTX	5.5	6.5	7.5	W
Rx		PRX	5	6	7	W	
TMDS	Data Output Load	RLD		50		Ω	
	Graphic Supply Voltage	GVCC	+ 3.15	+ 3.3	+ 3.45	V	
	Single-Ended High Level Input Voltage	GVIH	GVCC - 0.01	GVCC	GVCC + 0.01	V	
	Single-Ended Low Level Input Voltage	GVIL	GVCC - 0.6	-	GVCC - 0.4	V	
	Single-Ended Input Swing Voltage	GVISWING	0.2	-	0.75	V	
Ethernet Link	Maximum Bit rate			40		Mbps	
	Network Speed			100/1000		Mbps	
	RGMII/GMII	-0.2		2.8		V	

(T_A = 0 °C to +50 °C, unless otherwise noted)

- HDMI Pin Description

Pin	Symbol	Functional Description
1	CH2+	TMDS Data Signal Channel 2 Positive
2	GND	TMDS Data Signal Channel 2 Shield
3	Ch2-	TMDS Data Signal Channel 2 Negative
4	CH1+	TMDS Data Signal Channel 1 Positive
5	GND	TMDS Data Signal Channel 1 Shield
6	CH1-	TMDS Data Signal Channel 1 Negative
7	CH0+	TMDS Data Signal Channel 0 Positive
8	GND	TMDS Data Signal Channel 0 Shield
9	CH0-	TMDS Data Signal Channel 0 Negative
10	CLK+	TMDS Clock Channel Positive
11	GND	TMDS Clock Signal Shield
12	CLK-	TMDS Clock Channel Negative
13	CEC	Consumer Electronics Control
14	Reserved	Not used
15	SCL	HDCP/DDC communication clock
16	SDA	HDCP/DDC communication data
17	GND	DDC/CEC shield
18	5V	5 V Input for Transmitter from Host
		5 V Output for Monitor from Receiver
19	Hot plug Detect	Signal is driven by monitor to enable the system to identify the presence of a monitor

- Absolute Maximum Ratings

Parameter	Symbol	Minimum	Maximum	Units
Supply Adaptor Voltage, Temp=25°C	VCC	-0.3	+5.25	V
Operating Temperature	Top	0	50	°C
Operating Relative Humidity	RHop	5	80*	%RH
Storage Temperature	Tsto	- 30	+ 70	°C
Storage Relative Humidity	RHsto	10	95*	%RH

- Recommended Operating Conditions

Parameter	Symbol	Minimum	Typical	Maximum	Units
Ambient Operating Temperature	TA	0		+ 50	°C
Data Output Load (HDMI)	RLD		50		Ω
Power Supply Rejection (Note1)	PSR		100		mVp-p
Supply Voltage	VCC	+ 4.75	+ 5.0	+ 5.25	V

■ **EMC Test**

- EMI: Meet FCC class A or B (ICES-003) and CE class A or B

STANDARDS		CONDITIONS
EN 55 022 (CISPR22) FCC; PART 15 SUBPART B	CE (Conducted Emission) & RE (Radiated Emission)	Meet Class A or B
EN 61000-3-2 (IEC 61000-3-2)	Harmonics	Meet Class A or B
EN 61000-3-3 (IEC 61000-3-3)	Flickers	Meet Class A or B

- EMS: Meet CE standards (EN 55024) and CISPR24 equivalents

STANDARDS		CONDITIONS
EN 61 000-4-2:1995	Electrostatic Discharge Immunity (Air: 8kv, Contact: 4kv)	Meet Criterion A or B
EN 61 000-4-3:1996	Radiated RF E-Field (80~1000 MHz) 3V/m (AM 80%, 1kHz)	Meet Criterion A or B
EN 61 000-4-4:1995	Fast Transients (5kHz, 60Seconds)	Meet Criterion A or B
EN 61 000-4-5:1995	Surge Transients	Meet Criterion A or B
EN 61 000-4-6:1996	Conducted Susceptibility (CS) Radiated Susceptibility (RS)	Meet Criterion A or B
EN 61 000-4-11:1994	Voltage Dips, Interruption & Variation	Meet Criterion A or B, and C

■ Connection Diagram

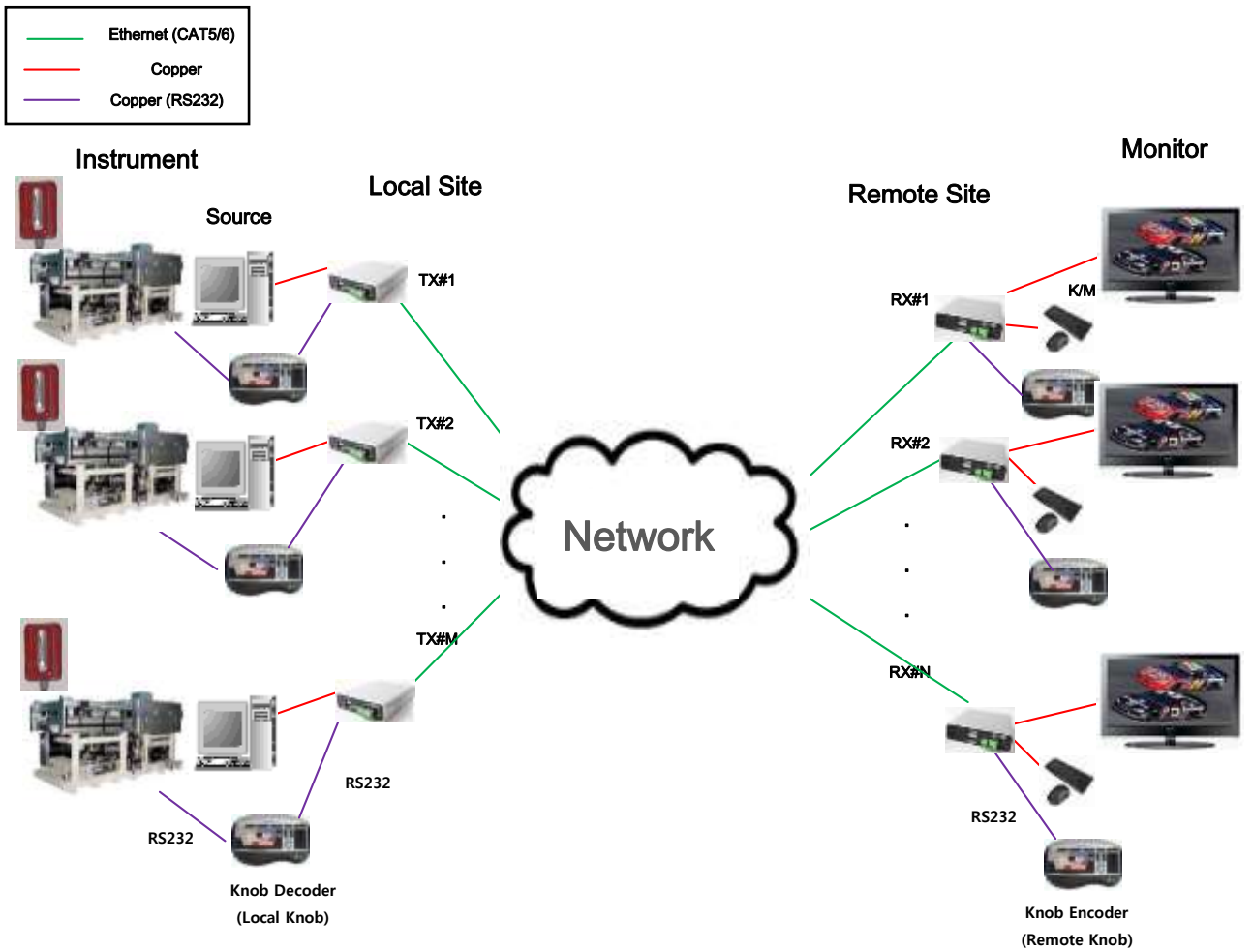

■ Block Diagram

Transmitter, IPKVM-310E: Internal schematic circuit diagram & I/O port

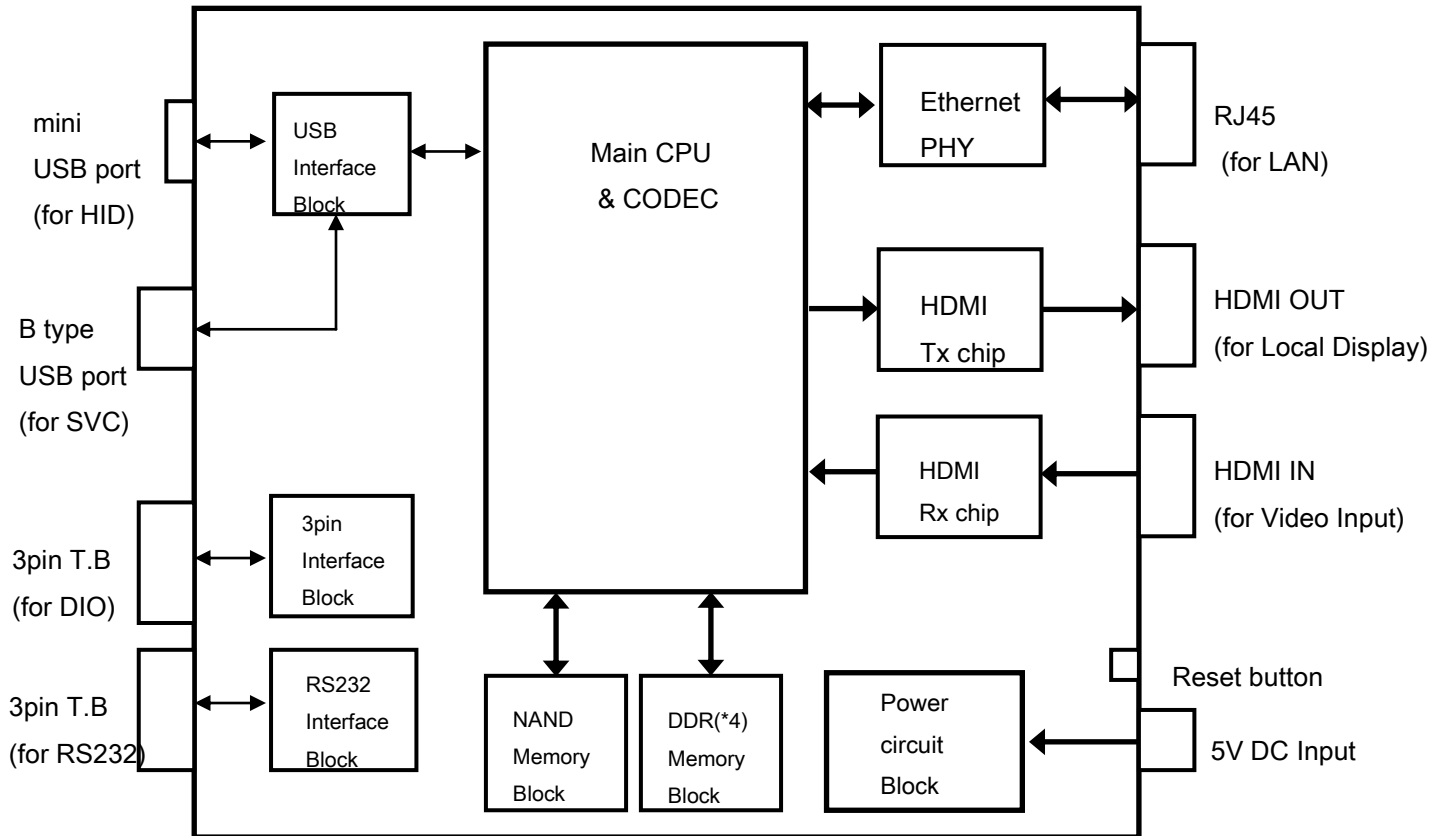

IPKVM-310(Ver. 1.0)

Receiver, IPKVM-310D : Internal schematic circuit diagram & I/O port

