

LCW620AD



Monitor size  
up to 29"



Max load  
8.4 to 17.8lb  
(3.8 to 8.1kg)

# Dual Articulating Wall Mount

FOR UP TO 29" MONITORS

The LCW620AD dual articulating wall mount features two attractive height adjustable articulating arms that provide perfect ergonomics with optimum monitor positioning for virtually all users. The wall mounting bracket allows for additional monitor placement when a desktop surface is not available.

*Peerless-AV's monitor mounts offer flexible monitor positioning, so the proper viewing angle can be found for all users.*



## Additional Features

- ✓ Articulating arms allow monitor to be adjusted to the perfect ergonomic position to help reduce eye, back and neck strain
- ✓ Accommodates different monitor weights ranging from 8.4 to 17.8lb (3.8 to 8.1kg)
- ✓ Smooth and effortless arm movement provided by bushings at all pivot points
- ✓ Compatible with VESA® 75 x 75 and 100 x 100mm mounting patterns
- ✓ 12.60" (320mm) of monitor height adjustment
- ✓ Mounts to wood, concrete, cinder block or breeze block construction
- ✓ Expertly finished polished aluminum arm and black base with chrome pole
- ✓ Integrated cable management provides clean, professional installation finish

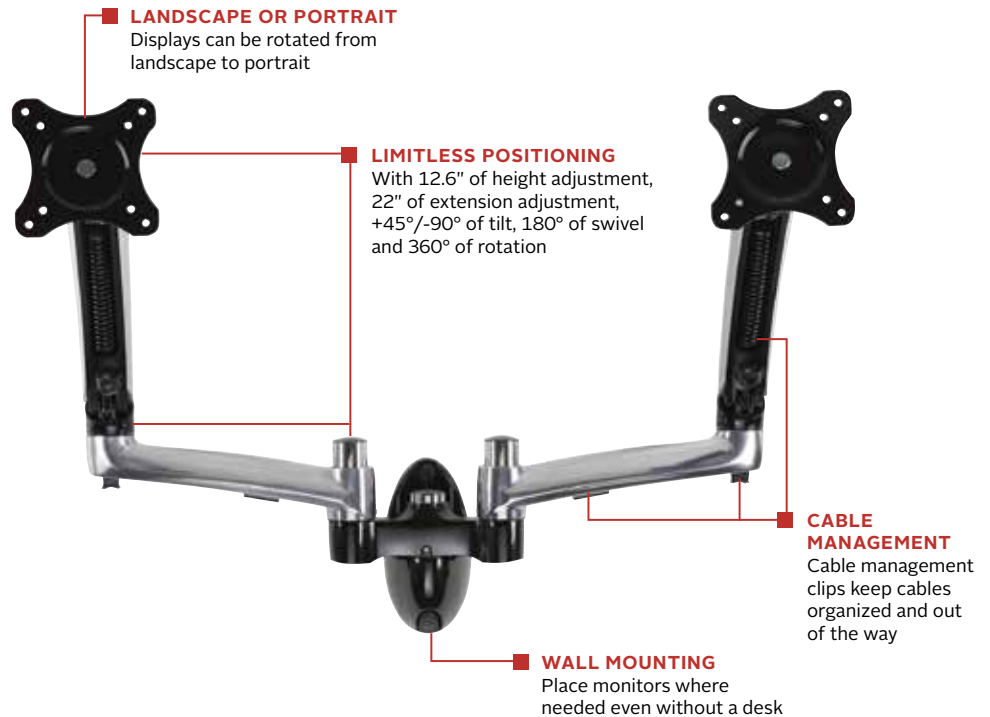

Cable management keeps a clean appearance



info@peerless-av.com  
peerless-av.com

peerless-AV®

**LCW620AD** Dual Articulating Wall Mount for up to 29" Monitors

**Product Specifications**

	DIMENSIONS (W X H X D)	PRODUCT WEIGHT	LOAD CAPACITY	FINISH	AVAILABLE COLORS
LCW620AD	(See Drawing)	17.60lb (8kg)	8.4 to 17.8lb (3.8 to 8.1kg)	High Gloss	Polished Aluminum with Black base and accents

**Package Specifications**

	PACKAGE SIZE (W x H x D)	PACKAGE SHIP WEIGHT	PACKAGE UPC CODE	PACKAGE CONTENTS	UNITS IN PACKAGE
LCW620AD	18.07" x 10.63" x 16.26" (459 x 270 x 413mm)	18.70lb (8.5kg)	735029279921	Wall Plate with Pole, Arm w/adaptor, Hardware & Mounting instructions	1

**Accessories**

- ACC328:** Laptop Tray
- ACC450:** VESA® 200 x 200mm Accessory Adaptor Plate
- ACC918:** Security Fasteners
- PTM200:** Universal Tablet Mount

All dimensions = inch (mm)

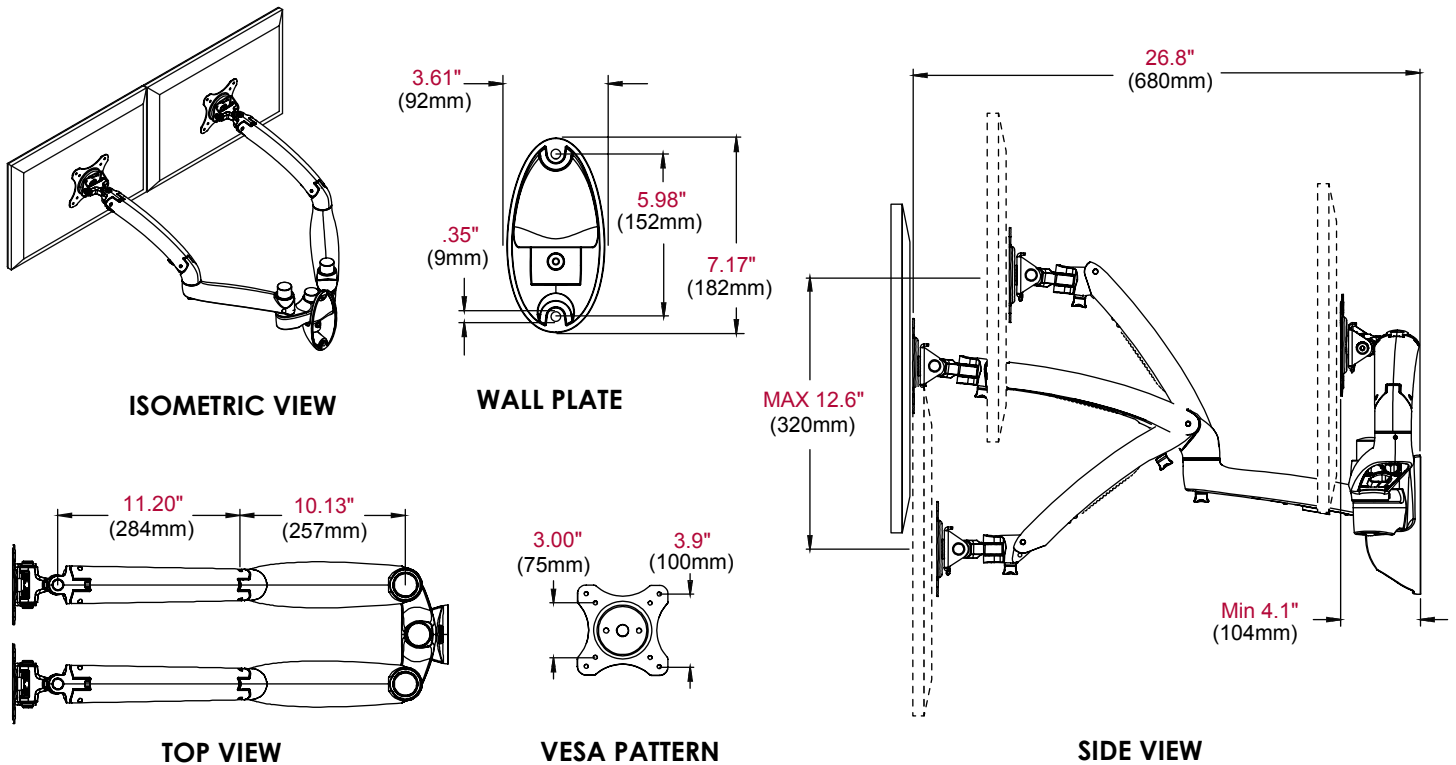

**Architect Specifications**

The Dual Articulating Wall Mount shall be a Peerless-AV model LCT620AD and shall be located where indicated on the plans. Assembly and installation shall be done according to instructions provided by the manufacturer.

Visit [peerless-av.com](http://peerless-av.com) to see the complete line of AV solutions from Peerless-AV, including outdoor displays, wireless, kiosks, digital audio, display mounts, projector mounts, carts/stands, and a full assortment of accessories.

**Peerless-AV**  
2300 White Oak Circle  
Aurora, IL 60502 USA  
**(800) 865-2112**  
**(630) 375-5100**  
**Fax: (800) 359-6500**

**Peerless-AV Europe**  
Unit 3 Watford Interchange  
Colonial Way, Watford  
Herts, WD24 4WP  
United Kingdom  
**+44 (0) 1923 200100**  
**Fax: +44 (0) 1923 200101**

**Peerless-AV de México**  
Ave de las Industrias 413  
Parque Industrial Escobedo  
Escobedo, N.L.,  
Mexico 66050  
**+52 (81) 8384-8300**  
**Fax: +52 (81) 8384-8360**

