

LCZ-2F430B

# Dual-Monitor Desktop Stand

## For up to 30" Monitors



This beautiful sleek desktop stand raises two monitors off the desk surface, thus saving workspace and creating a productive display configuration to increase productivity. Adjust the height and position of the monitors to the ideal viewing point. It is quick and simple with the adjustable locking system which allows the user to move and lock the monitors freely along the vertical rail without using any tools.

### FEATURES

- Supports two 30" monitors on a 35.4" (900mm) crossbar
- Easy to assemble and requires 2 square feet of desktop space
- 12" (305mm) of height adjustment for the ideal viewing point
- 5.3" (134mm) distance from the vertical rail
- 75 and 100 VESA® mounting pattern



Display size: up to 30"



Max load: 39.6lb (17.9kg)  
Display (ea): 19.8lb (8.9kg)

### ■ QUICK AND EASY POSITIONING

A unique adjustable locking system allows moving and locking the displays freely along the vertical rail without using tools



### ■ CABLE MANAGEMENT

Thread cables along the horizontal crossbar to keep cables and cords out of sight and protected for a clean uncluttered desktop



Easy height adjustment



Move and lock monitors



**RoHS**  
PROHIBITED

**LCZ-2F430B** Dual-Monitor Desktop Stand for up to 30" Monitors

Product Specifications

	DIMENSIONS (W x H x D)	PRODUCT WEIGHT	LOAD CAPACITY	FINISH	AVAILABLE COLORS
<b>LCZ-2F430B</b>	35.4" x 12.9" x 15.7" (900 x 327 x 400mm)	16.9lb (7.6kg)	19.8lb (9kg) per display	Powder coat epoxy	Black

Package Specifications

	PACKAGE SIZE (L x W x H)	PACKAGE SHIP WEIGHT	PACKAGE UPC CODE	PACKAGE CONTENTS	UNITS IN PACKAGE
<b>LCZ-2F430B</b>	38.6" x 4.7" x 17.1" (980 x 119 x 434mm)	20.7lb (9.3kg)	735029278108	Base, Cover, Post, Crossbar, 2 display mounts, Mounting hardware, Cable management clips	1

Accessories

- PTM200(-S):** Universal Tablet Cradle
- ACC450:** VESA® 200 x 200mm Accessory Plate
- ACC918:** Security Fasteners

All dimensions = inch (mm)

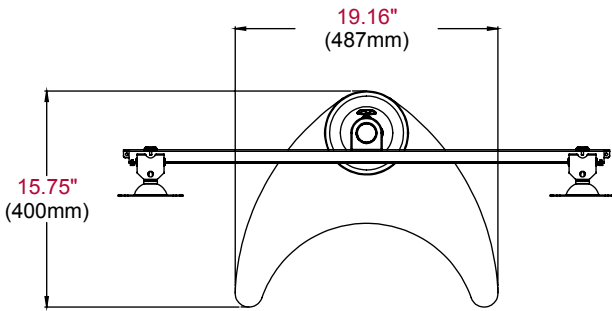

TOP VIEW

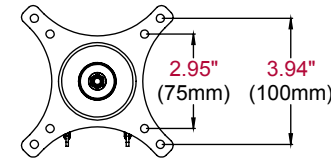

ADAPTER PLATE

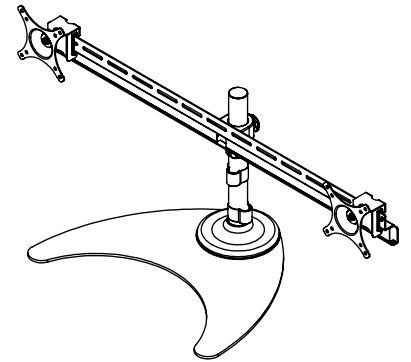

ISOMETRIC VIEW

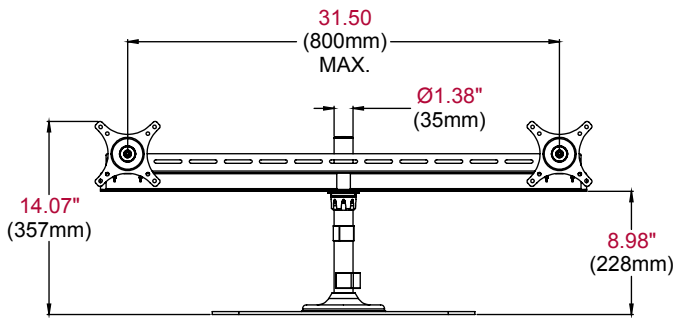

FRONT VIEW

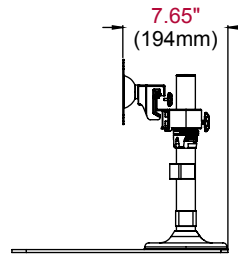

SIDE VIEW

ARCHITECTS SPECIFICATIONS

The Peerless-AV Dual-Monitor Desktop Stand shall be model # LCZ-2F430B and shall be located where indicated on the plans. It shall have a 19.8lb load capacity per display. It shall be finished in black. Assembly and installation shall be done according to instructions provided by the manufacturer.

Peerless Industries, Inc. ■ 2300 White Oak Circle ■ Aurora, IL 60502 ■ (800) 865-2112 ■ (630) 375-5100 ■ Fax: (800) 359-6500 ■ peerless-av.com

Visit peerless-av.com to see the complete line of AV solutions from Peerless-AV, including flat panel mounts, projector mounts, carts/stands, furniture, cables, screen cleaners and a full assortment of accessories.