

LCZ-3F419B

# Triple-Monitor Desktop Stand for up to 17" Monitors



This beautiful sleek desktop stand raises three monitors off the desk surface, thus saving workspace and creating a productive display configuration to increase productivity. Adjust the height and position of the monitors to the ideal viewing point. It is quick and simple with the adjustable locking system which allows the user to move and lock the monitors freely along the vertical rail without using any tools.

## FEATURES

- Supports three 17" monitors with a max display width of 15.75" (400mm)
- Easy to assemble and requires 2 square feet of desktop space
- 12" (305mm) of height adjustment for the ideal viewing point and 5.3" (134mm) distance from the vertical rail
- 75 and 100 VESA® mounting pattern



Display size: up to 17"



Max load: 59.4lb (26.9kg)  
Display (ea): 19.8lb (8.9kg)

### ■ QUICK AND EASY POSITIONING

A unique adjustable locking system allows moving and locking the monitors freely along the vertical rail without using tools



### ■ CABLE MANAGEMENT

Thread cables along the horizontal crossbar to keep cables and cords out of sight and protected for a clean uncluttered desktop



Easy height adjustment



Move and lock monitors



RoHS

**LCZ-3F419B** Triple-Monitor Desktop Stand for up to 17" Monitors

**Product Specifications**

	<b>DIMENSIONS (W x H x D)</b>	<b>PRODUCT WEIGHT</b>	<b>LOAD CAPACITY</b>	<b>FINISH</b>	<b>AVAILABLE COLORS</b>
<b>LCZ-3F419B</b>	36.18" x 12.92" x 15.75" (919 x 328 x 400mm)	17.6lb (7.9kg)	19.8lb (9kg) per display	Powder coat epoxy	Black

**Package Specifications**

	<b>PACKAGE SIZE (L x W x H)</b>	<b>PACKAGE SHIP WEIGHT</b>	<b>PACKAGE UPC CODE</b>	<b>PACKAGE CONTENTS</b>	<b>UNITS IN PACKAGE</b>
<b>LCZ-3F419B</b>	38.60" x 4.70" x 17.10" (980 x 119 x 434mm)	21.9lb (9.9kg)	735029278115	Base, Cover, Post, Crossbar, 3 display mounts, Mounting hardware, Cable management clips	1

**Accessories**

- PTM200(-S):** Universal Tablet Cradle
- ACC450:** VESA® 200 x 200mm Accessory Plate
- ACC918:** Security Fasteners

All dimensions = inch (mm)

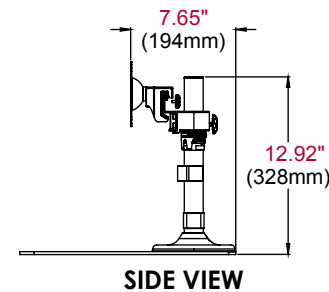
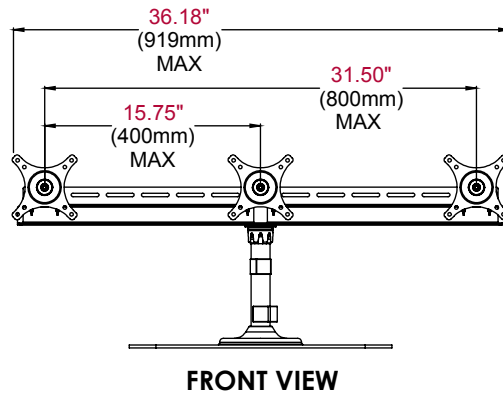
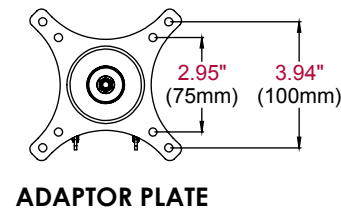
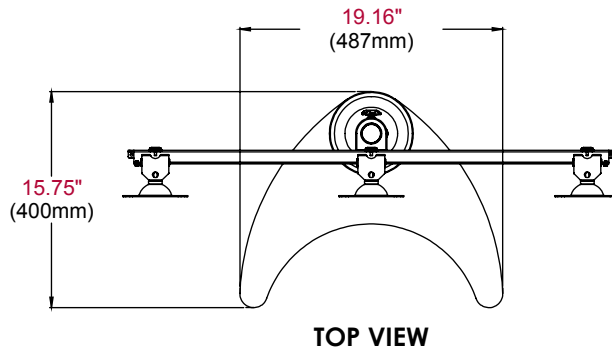

**ARCHITECTS SPECIFICATIONS**

The Peerless-AV Triple-Monitor Desktop Stand shall be model # LCZ-3F419B and shall be located where indicated on the plans. It shall have a 19.8lb load capacity per display. It shall be finished in black. Assembly and installation shall be done according to instructions provided by the manufacturer.