

DATA SHEET

Optical Dual Link DVI Module

M1-3R2VI-DU

Contents

- ◆ Description
- ◆ Features
- ◆ Applications
- ◆ Technical Specifications
- ◆ Functions
- ◆ Drawing of Modules
- ◆ Drawing of Cable Connections
- ◆ DVI Pin Description
- ◆ Pin Description of DDC Connector
- ◆ Reliability Test

Headquarter

Opticis Co., Ltd.
501, ByucksanTechnopia,
434-6 Sangdaewon-Dong, Chungwon-Ku
Sungnam City, Kyungki-Do, 463-120
South Korea
Tel: +82 (31) 737-8033~9
Fax: +82 (31) 737-8079

www.opticis.com

Opticis North America, Inc.

330 Richmond Street, Suite 100,
Chatham, Ontario
CANADA N7M 1P7

Tel : (519) 355-0819
Fax : (519) 355-0520

Email : roger@opticis.com

Optical DVI Dual Link Extension Module

- Fiber Detachable Connection System of DVI Dual Link -

Description

The M1-3R2VI-DU DVI Module is a new member of the Opticis family of products that stretches your DVI connectivity. It offers a fiber-optic long-distance extension of dual link DVI connectors. DDC connection is implemented over a CAT5e cable with RJ-45C.

The reality of high-speed digital graphic interconnections mandates products to maintain video quality and cost effectiveness of integrated display systems. Optical technology for gigabit digital transmission makes it simple to extend digital graphic data above the extension limits of copper wires providing pure signal integrity for an ideal visual experience, no EMI/RFI emissions, light weight, rugged cabling and connectors, low power consumption and installation ease.

The extension system consists of transmitter and receiver module boxes with female dual link DVI-D plugs, being able to connect PCs (Media Receiver) and displays (Monitor or HDTV) by dual link DVI-D copper cables respectively. Two (2) duplex LC patch cord fiber cables enable to transmit graphic data, 7 channels including a clock.

The module also provides self-EDID programming feature that makes pure optical interconnection realized. It makes installation of M1-3R2VI-DU much easier and more flexible at any displays of various resolution types. The module extends DVI dual link data of WQXGA (2,560x1,600) resolution up to 2km (6, 600 feet) with virtual DDC.

The shipping group is shown as follows;

- 1) 1ea x DVI Dual link Transmitter Module
- 2) 1ea x DVI Dual link Receiver Module
- 3) 2ea x DVI Dual link Copper Cable (1.8m)
- 4) 1ea x 24V Power Supply Adapter (AC 85-264V, 50/60Hz)
- 5) 1ea x AC Cord (US Type or EU type)
- 6) 1ea x User Manual
- 7) Option : 2 duplex LC Patch Cord Cable, CAT5e Cable, One more +24V Power Adapter for virtual DDC

Features

- ◆ Supports up to 2,560x1,600 resolution at 60Hz refresh rate.
- ◆ Extends up to 100 m (328 feet) with DDC2B.
2 km (6,600 feet) with virtual DDC.
- ◆ Fiber-optic cables with four (4) LC or two (2) duplex LC fiber connectors are required to transmit Red, Green, and Blue, three (3) channels for each link and one clock.
- ◆ Offers DVI single link DVI connection through two (2) LC or one (1) duplex LC LC fibers.
- ◆ Provides self-EDID programming feature, detecting from a display and restoring to an EEPROM in the transmitter just by plugging to the display without any physical DDC connection.
- ◆ Applicable to both single and multi-mode fiber.
- ◆ Light weight detachable cables with secure connectors for fiber and copper.
- ◆ No software to install - plug & play simplicity.
- ◆ Low EMI/RFI emissions and inherent fiber data security.
- ◆ Complies with FDA/CDRH and IEC 60825-1 Class 1 Laser Eye Safety.
- ◆ Adopts only an external power supply, +24V to supply both modules over CAT5e cable.
- ◆ Uses 1310/1550nm single-mode light sources and equivalent photo detectors.

Applications

- ◆ Power Mac G5 with graphic cards supporting Dual Link DVI and 30" Cinema Display
- ◆ Medical, military, aerospace, factory, and traffic control integrated digital display systems
- ◆ Digital TFT-LCD and plasma flat panel displays and projectors for conference room, auditorium, airports, stadium and kiosk systems.
- ◆ Digital Home Theatre Systems

Technical Specifications

- General Specifications

	Parameter	Specifications
Components	Laser Diodes in Tx Module	1310nm/1550nm BIDI Transmitter with FP-LD
	Photo Diodes in Rx Module	1310nm/1550nm BIDI receiver with GaAs PIN-PD
Electrical	Input and Output Signals	TMD5 Level (complying with DV11.0)
	Data Transfer Rate (Graphic Data)	Max. 1.62Gbps
	Total Jitter at the end of Rx output	Max. 309 ps
	Skew inter-channels	Max. 6ns
Optical	Link Power Budget	Min 10.5dB
Mechanical	Module dimension (mm)	111.8WX31HX215.9L
Connect	Optical Connector	2 Duplex LC connectors
	Electric Connector Type from Modules and to Displays	24 pin DVI-D plug
	Recommended Fiber	62.5/125 or 50/125 um Multi-mode Glass Fiber 9/125um Single-mode Glass Fiber

Note*: some plastic couplers to clamp two LC connectors could not fit in.

- Absolute Maximum Ratings

Parameter	Symbol	Minimum	Maximum	Units
Storage Temperature	T _{stg}	- 10	+ 85	°C
Supply Voltage	V _{CC}	10	16	V
Transmitter Differential Input Voltage	V _d	-	1	V
Relative Humidity	RH	5	85	%
Lead Soldering Temperature & Time	-	-	-	260°C, 10 sec

Note*: Under the condition of No drops of dew

- Recommended Operating Conditions

Parameter	Symbol	Minimum	Typical	Maximum	Units
Ambient Operating Temperature	T _A	0		50	°C
Data Output Load	R _{LD}		50		Ω
Power Supply Rejection (Note1)	PSR		50		mV _{p-p}
Supply Voltage	V _{CC}	+ 22	+ 24	+ 26	V

Note1. Tested with a 50mV_{p-p} sinusoidal signal in the frequency range from 500 Hz to 500 MHz on the V_{CC} supply with the recommended power supply filter in place. Typically less than a 0.25 dB change in sensitivity is experienced.

- Electrical Power Supply Characteristics

(T_A = 0 °C to +50 °C, unless otherwise noted)

Parameter	Symbol	Minimum	Typical	Maximum	Units	
Supply Voltage	V _{CC}	22	24	26	V	
Supply Current	TX	I _{TCC}	180	220	270	mA
	RX	I _{RCC}	270	330	380	mA
Power Dissipation	TX	P _{TX}	3.8	5.3	7.2	W
	RX	P _{RX}	5.8	7.9	10.0	W

- **Optical & Electrical Characteristics** ($T_{op} = 25^{\circ}C$)

Parameters	Symbol	Condition	Unit	Min.	Typ.	Max.	Remark
Data Bit Rate	1310 Tx	PRBS 2 ⁷ -1,NRZ	Mbps		1250	1650	
	1550 Rx				155.52		
	1550 Tx	PRBS 2 ⁷ -1,NRZ	Mbps		155.52		
	1310 Rx				1250	1650	
Fiber Length 9μm core SMF		10 ⁻¹⁰ BER, 155Mbps /1.25Gbps	km	2			
TRANSMITTER							
Average Launched Power	P _{OUT}	I _f =I _{BIAS} + I _{mod} /2	dBm	-10		0	
Extinction Ratio	ER		dB	5			
Center Wavelength	c	CW, @ P _{OUT}	nm	1260 1480	1310 1550	1360 1580	@1.31 μm @1.55 μm
Spectral Width		RMS Width	nm			2.1	
RIN			dB/Hz			-120	
Data Input Differential Voltage	V _{IN}		mV	200		1600	
Optical Rise/Fall Time	t _r /t _f	20 – 80%	nsec			0.26 2.0	
RECEIVER							
Maximum Input Power	P _{in}		dBm	0			
Sensitivity	P _s		dBm			-17	155M Rx 1.65G Rx
Wavelength	1310 1550		nm	1260 1500	1310 1550	1360 1600	
Receiver Overload	P _{IN,MAX}		dBm	-3.0			
Signal Detect Threshold							
Decreasing light input	P _D		dBm		P _{IN,MIN} -3		
Increasing light input	P _A		dBm		P _{IN,MIN} -2		
LOS Hysteresis			dB	1			

- **TMDS Characteristics**

	Parameter	Symbol	Minimum	Typical	Maximum	Units
Transmitter TMDS	Data Output Load	R _{LD}		50		Ω
	Graphic Supply Voltage (Note2)	GV _{CC}	+ 3.1	+ 3.3	+ 3.5	V
	Single-Ended High Level Input Voltage	GV _{IH}	GV _{CC} - 0.01	GV _{CC}	GV _{CC} + 0.01	V
	Single-Ended Low Level Input Voltage	GV _{IL}	GV _{CC} - 0.6	-	GV _{CC} - 0.4	V
	Single-Ended Input Swing Voltage	GV _{ISWING}	0.4	-	0.6	V
Receiver TMDS	Data Input Load	R _{LD}		50		Ω
	Graphic Supply Voltage (Note3)	GV _{CC}	+ 3.1	+ 3.3	+ 3.5	V
	Single-Ended Output Swing Voltage (Note4)	GV _{ISWING}	0.4	-	0.6	V

Note2. Graphic Supply Voltage is regulated reference voltage for signal processing in modules

Note3. Graphic Supply Voltage is regulated reference voltage for signal processing in modules

Note4. TMDS outputs are coupled in AC

Functions

- Self-EDID Function

The EDID in a display can be read and restored by just plugging it to the display. This self-EDID programming feature makes the installation of M1-3R2VI-DU more easy and flexible at any variable resolution display systems.

- Power Save Mode in Transmitter Module

The laser diodes work only when +5V voltage should be supplied into the 14-pin in DVI connectors, that is, detecting plugging the DVI plug to the PC. The voltage passing through a regulator from the +5V PC power or external power has LD drive circuit work.

- Signal Detect Mode in Receiver Module

It offers squelch function blocking output signals when optical input power is lower than as specified in a certain case, that is, detecting losing the LC fiber-optic patch cord.

Drawing of Modules

Dimension [mm]

Note: The transmitter, M1-3R2VI-DU-T and the receiver, M1-3R2VI-DU-R have the same mechanical dimensions.

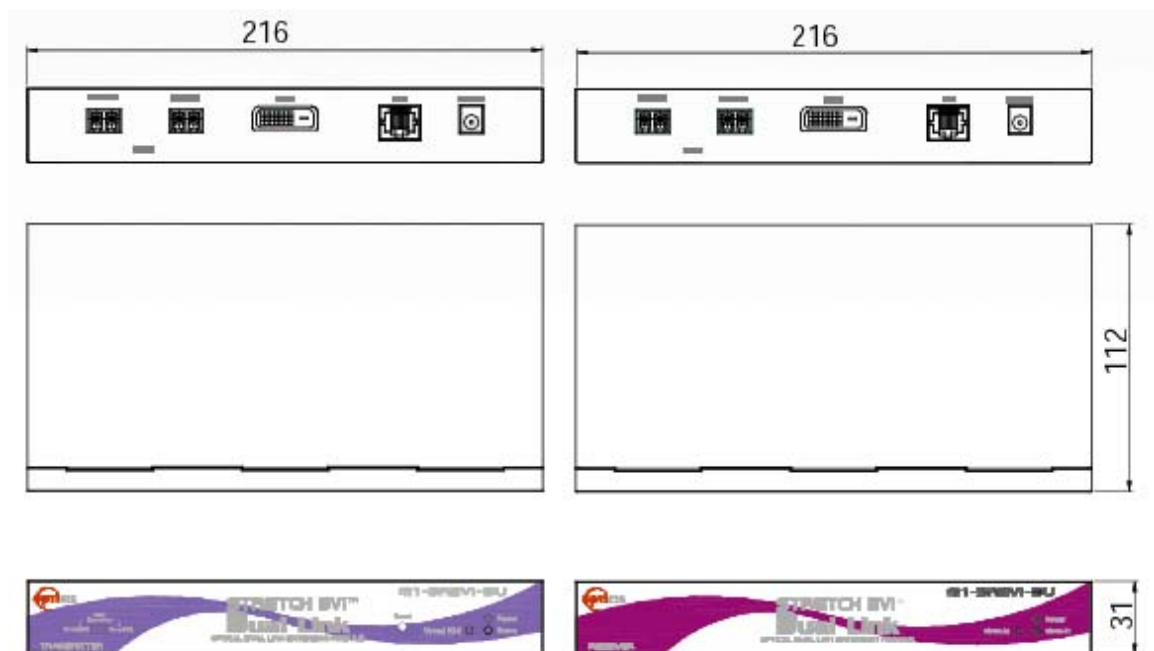

Drawing of Cable Connections

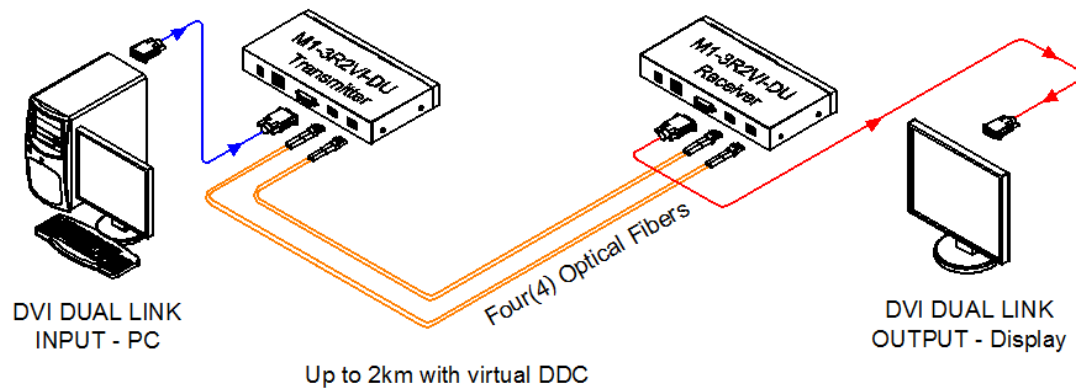
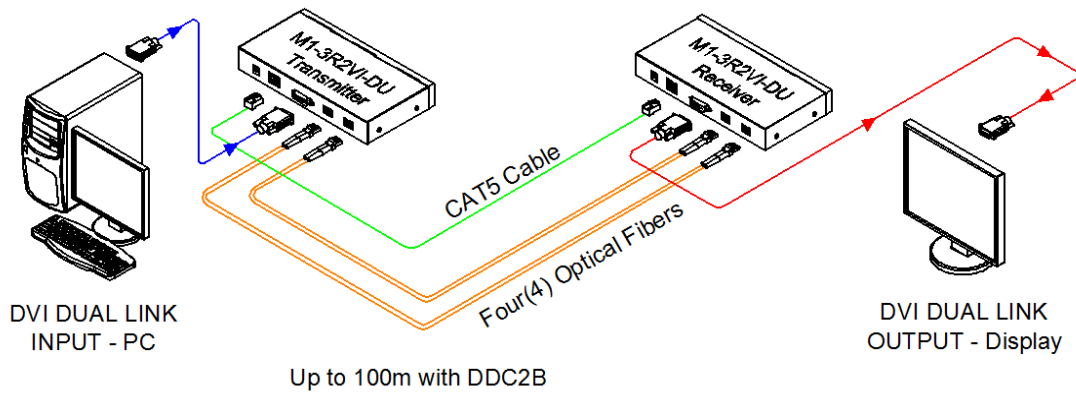

Pin Description for DDC Connector

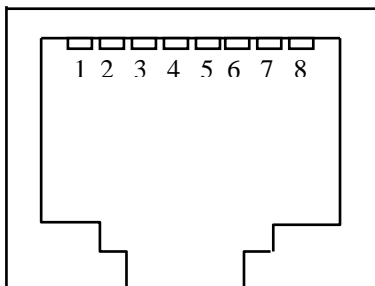

Pin	Symbol	Functional Description
1	DDC Data GND	DDC Data line return ground
2	DDC Data	DDC Data line for DDC2B communication
3	DDC Clock GND	DDC Clock line return ground
4	Power GND	Main power return ground
5	Power	Main power for Opticis module
6	DDC Clock	DDC Clock line for DDC2B communication
7	Power GND	Main power return ground
8	Power GND	Main power return ground

DVI Pin Description

Pin	Symbol	Functional Description
1	CH2-	TMDS Data Signal Channel 2 Negative
2	CH2+	TMDS Data Signal Channel 2 Positive
3	GND	TMDS Data Signal Channel 2/4 Shield
4	CH4-	TMDS Data Signal Channel 4 Negative
5	CH4+	TMDS Data Signal Channel 4 Positive
6	DDC Clock	DDC Clock line for DDC2B communication
7	DDC Data	DDC Data line for DDC2B communication
8	N.C.	
9	CH1-	TMDS Data Signal Channel 1 Negative
10	CH1+	TMDS Data Signal Channel 1 Positive
11	GND	TMDS Data Signal Channel 1/3 Shield
12	CH3-	TMDS Data Signal Channel 3 Negative
13	CH3+	TMDS Data Signal Channel 3 Positive
14	5 V	5 V Input for Transmitter from Host
		5 V Output for Monitor from Receiver
15	GND	Ground
16	Hot plug Detect	Signal is driven by monitor to enable the system to identify the presence of a monitor
17	CH0-	TMDS Data Signal Channel 0 Negative
18	CH0+	TMDS Data Signal Channel 0 Positive
19	GND	TMDS Data Signal Channel 0/5 Shield
20	CH5-	TMDS Data Signal Channel 5 Negative
21	CH5+	TMDS Data Signal Channel 5 Positive
22	GND	TMDS Clock Signal Shield
23	CLK-	TMDS Clock Channel Negative
24	CLK+	TMDS Clock Channel Positive

Reliability Test

We have three kinds of test criteria for a reduction of variability and a continuous improvement of the process by our FMEA (Failure Mode and Effective Analysis) program.

- 1) Mechanical test (Vibration, Shock)
- 2) Temp. & Humidity test
- 3) EMC test (FCC class A and CE Verification for M1-3R2VI-DU)

Mechanical and Temp. & Humidity Test

Heading	Test	Conditions	Duration	Sample Size	Remarks
Operating Test	Operating at each Temperature (See Note)	-10~50°C (Interval: 10°C)	30 Min (Each Temperature)	n=3	Note: Evaluate display quality of Laser Beam Projector connected to Graphic Signal Generator (Quantum Data: GD-802B) at each temperature. 1. T _S : Storage Temperature 2. RH: Relative Humidity
Storage Test	Low Temperature	T _S = -30°C	96 HR	n=3	
	High Temperature	T _S = 60°C	96 HR	n=3	
	High Humidity / High Temperature	T _S : 60°C RH: 85%	96 HR	n=3	
Mechanical Test	Mechanical Shock	Pulse: 11 ms Peak level: 30 g Shock pulse: 6times/Axis	-	n=3	
	Mechanical Vibration	Peak acceleration: 5 g Frequency: 10~55 Hz Sweep time: 5 Minutes 2 Times/Axis	-	n=3	

EMC Test



1) EMI: Meet FCC class A (ICES-003) and CE class A

STANDARDS		CONDITIONS
EN 55 022 (CISPR22) FCC; PART 15 SUBPART B	CE (Conducted Emission) & RE (Radiated Emission)	Meet Class A
EN 61000-3-2 (IEC 61000-3-2)	Harmonics	Meet Class A
EN 61000-3-3 (IEC 61000-3-3)	Flickers	Meet Class A

2) EMS: Meet CE standards (EN 55024) and CISPR24 equivalents

STANDARDS		CONDITIONS
EN 61 000-4-2:1995	Electrostatic Discharge Immunity (Air: 8kv, Contact: 4kv)	Meet Criterion A or B
EN 61 000-4-3:1996	Radiated RF E-Field (80~1000 MHz) 3V/m (AM 80%, 1kHz)	Meet Criterion A or B
EN 61 000-4-4:1995	Fast Transients (5kHz, 60Seconds)	Meet Criterion A or B
EN 61 000-4-5:1995	Surge Transients	Meet Criterion A or B
EN 61 000-4-6:1996	Conducted Susceptibility (CS) Radiated Susceptibility (RS)	Meet Criterion A or B
EN 61 000-4-11:1994	Voltage Dips, Interruption & Variation	Meet Criterion A or B, and C