



Pathfinder 500 series

MG-KVM-531

MG-KVM-532

User Guide V1.00

In this guide

Hardware recommendations	1
Multi-mode optical fiber.....	2
Single-mode optical fiber	2
Network switches.....	2
RS-232 connector pinning.....	2
RJ11 connector pinning	2
System requirements for Pathfinder Control.....	2
About your Pathfinder 500 series device.....	3
About the status LED light	5
Fitting or replacing the SFP module	6
Installing single and multiple endpoints	6
Extending a single PC	6
Connecting to multiple endpoints	7
Quick start	8
Connecting your hardware	9
Setting up your system in Pathfinder Control	9
To set up your system in Pathfinder Control	10
Updating your firmware.....	11
Connecting encoders and decoders in Pathfinder Control	12
Next steps	12
The on-screen display – the Home menu	13
Opening the on-screen display	13
The Home menu	13
Connecting and disconnecting with the on-screen display	14
Opening the on-screen display	14
Using keyboard shortcuts	14
Connecting and disconnecting.....	14
To log in to a PC.....	14
To connect to an encoder	14
To disconnect from an encoder	14
To open a point-to-point connection.....	15
Searching in a list	15
Managing devices with the on-screen display.....	15
Opening the on-screen display	15
Getting information about your status	15
Choosing and using favorite devices	16
To choose a favorite device.....	16

To view your list of favorite devices	16
To connect to a favorite encoder	16
Sharing your connection with another user	16
To switch between the Share Device Push and Share Device Get menus	17
To push your connection to another user	17
To view another user's connection	17
To control another user's PC.....	17
Managing settings with the on-screen display	18
Opening the on-screen display	18
Defining what DDC or EDID data your PC uses	18
Managing encoder settings	18
Changing your display settings	19
Managing decoder settings	20
Setting the audio volume	20
Setting a baud rate for your RS-232 connection	20
Choosing what to show on the decoder monitor when there is no connection	21
Power save mode.....	22
Protecting your PC from viruses from a USB drive	22
Selecting QWERTY, AZERTY, or QWERTZ keyboard layout.....	22
Changing keyboard fallback mode.....	22
Changing your keyboard shortcuts.....	23
Hiding the status menu	23
Locking the on-screen display	23
Enabling other users to control your PC when you share your connection	24
Enabling HDCP protected video	24
Reducing video tearing with monitor synchronization.....	25
Network settings and more.....	25
Troubleshooting and FAQs.....	26
Updating your firmware.....	26
No power is getting to my Pathfinder device	26
My USB keyboard or mouse isn't working	26
No video is reaching the monitor connected to the decoder.....	27
Video is poor quality or stripy	27
I can't hear any audio	27
General troubleshooting checklist.....	27
Returning a product for repair	28
Contact us.....	29

Thanks for buying this Magenta Pathfinder 500 series device. Pathfinder 500 series devices provide a scalable, zero latency, KVM (Keyboard, Video, Mouse, and USB 2.0) extension and switching solution. Capable of over 3000 high-quality endpoints in a single system, Pathfinder is the perfect solution for mission critical control and collaboration including medical, broadcast, and control room operations. Pathfinder devices come with a choice of Small Form-factor Pluggable (SFP) transceivers. Choose from single-mode optical fiber, multi-mode optical fiber, or RJ45 Ethernet for a fully flexible experience.

The Pathfinder 500 series includes:

- 1x MG-KVM-531 HD DVI encoder
- 1x MG-KVM-532 HD DVI decoder

Pathfinder Features

Some features are only available in Pathfinder networks that include 500 and 800 series devices.

- KVM matrixing solution with over 3000 endpoints
- Use either Ethernet or fiber optic cable for KVM, USB, and video
- Up to 4K @60 Hz video
- Mix-and-match HD and 4K endpoints
- Zero latency performance
- Point-to-point extension up to 20 km (12 miles)
- Mix copper and fiber cables for maximum flexibility in your system design
- Plug'n'play installation over IP
- Monitor up to 4 PCs from a single 4K monitor, keyboard, and mouse
- Extend PC desktop to dual displays over single cable
- Local monitor loop out

Hardware recommendations

At tvONE, we design our products to the highest quality standards. To get the best results from our products, we recommend that you use the best quality connectors, cables, and adapters. Consider the points below when you choose accessories and position equipment.

- For best results with HDMI/DVI, use cables under 15 m long, or shorter if you use connection adapters, or your signal is 4K. If you need to place your products more than 15 m apart, use a signal extender.
- See our range of signal extenders at tvone.com/signal-extension-systems.
- For best results with HDMI, use High Speed or Premium High Speed HDMI cables.
- In industrial environments, use shielded Ethernet cables for signal extension systems.
- Shielded Ethernet cables are often marked F/UTP or FTP. Use shielded Cat 6 cables with HDBaseT input and output modules and Streaming media and 4K playback input modules.

Multi-mode optical fiber

- Maximum length 500 m (1640 feet).
- Duplex Multimode 50/125 μ (OM2).
- LC connector 850 nm.

Single-mode optical fiber

- Maximum length 20 km (12.43 miles).
- Duplex single-mode.
- LC connector 310 nm TX -1550 nm RX.

Network switches

Your Pathfinder network requires its own dedicated network. As Pathfinder uses multicast, you must place it on its own VLAN or dedicated switches.

The network switch must fulfil the following specifications:

- The Pathfinder 500 series requires a 1 Gigabit switch, with true port-to-port transfer rates of 1 Gigabit/second.
- Network switches must support IGMP snooping and IGMP snooping must be switched on.

RS-232 connector pinning

Encoder			Decoder		
Pin	Function	Direction	Pin	Function	Direction
2	TxD	OUT	2	RxD	IN
3	RxD	IN	3	TxD	OUT
4	DTR	IN	4	DTR	OUT
5	GND	—	5	GND	—
8	CTS	OUT	8	CTS	IN

The pin numbers refer to a 9-pin D-sub plug.

RJ11 connector pinning

RJ11 pin	Function	Direction	
1	CTS	In	forwarded to partner DTR
2	DTR	Out	forwarded from partner CTS
3	TXD	Out	Serial Data
4		GND	
5	RXD	In	Serial Data
6	RTS	1k Resistor to DTR	Some applications need RTS pulled high

System requirements for Pathfinder Control

- Windows 7 (32bit/64bit) or higher
- 1 GB RAM
- 50 MB free storage
- 1 Gbit dedicated network interface

About your Pathfinder 500 series device

The Pathfinder 500 series includes a DVI encoder and decoder, capable of extending a 1080p signal up to 20 km (12 miles).

MG-KVM-531 encoder rear panel



DVI IN DVI-I in. Connect to the PC you want to control.

 Audio in from PC.
Connect to the PC with 3.5 mm jack.

RS232 Connect to a control device with Ethernet cable.

 Audio out to PC.
Connect to the PC with 3.5 mm jack.

DVI LOOP OUT DVI-I out. Connect to a monitor.

12VDC Connect to 12 V power supply.

USB Connect to USB port of PC.

KVM-LINK Depending on your SFP, connect to one of the following:

- Single-mode optical fiber cable
- Multi-mode optical fiber cable
- Ethernet cable

MG-KVM-532 decoder rear panel



 Audio in.
Connect an audio input device, for example, a microphone.

RS232 Connect a control device.

 Audio out.
Connect to an audio output device, for example, speakers.

12VDC Connect to 12 V power supply.

DVI OUT DVI-I out.
Connect to a monitor.

USB 2.0 Connect to a keyboard, a mouse, and any other USB devices.

KVM-LINK Depending on your SFP, connect to one of the following:

- Single mode optical fiber cable
- Multi mode optical fiber cable
- Ethernet cable

About the status LED light



The Status LED light can be red, orange, or green.

Color	Blinking	Physical link	Active connection	Video extended	USB Initialization	USB data received	Identify command	Auto-update mode
Main LED								
Red	None	Yes	No	No				Update failed
Red	Slow	No	No	No				
Orange	None	Yes	Yes	No				
Orange	Fast							Update in progress
Green	None	Yes	Yes	Yes				Update succeeded
Green	V. fast				Yes		Yes	
Red/Green	V. fast							
Ethernet port LEDs, 500 series only								
Yellow	None	No						
Yellow	Slow	Yes						
Green	None			Yes				
Green	V. fast					Yes		

Read troubleshooting information on page 26.

Connecting to multiple endpoints

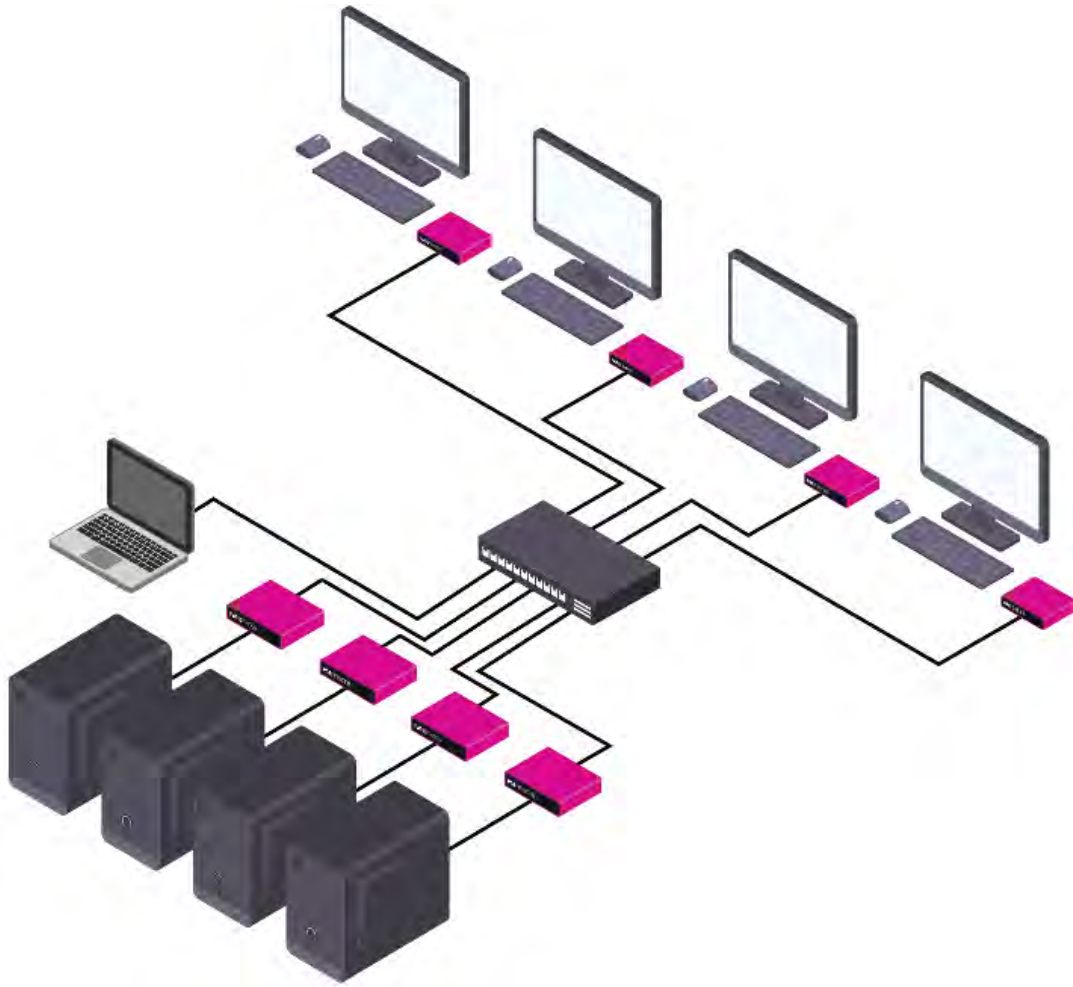



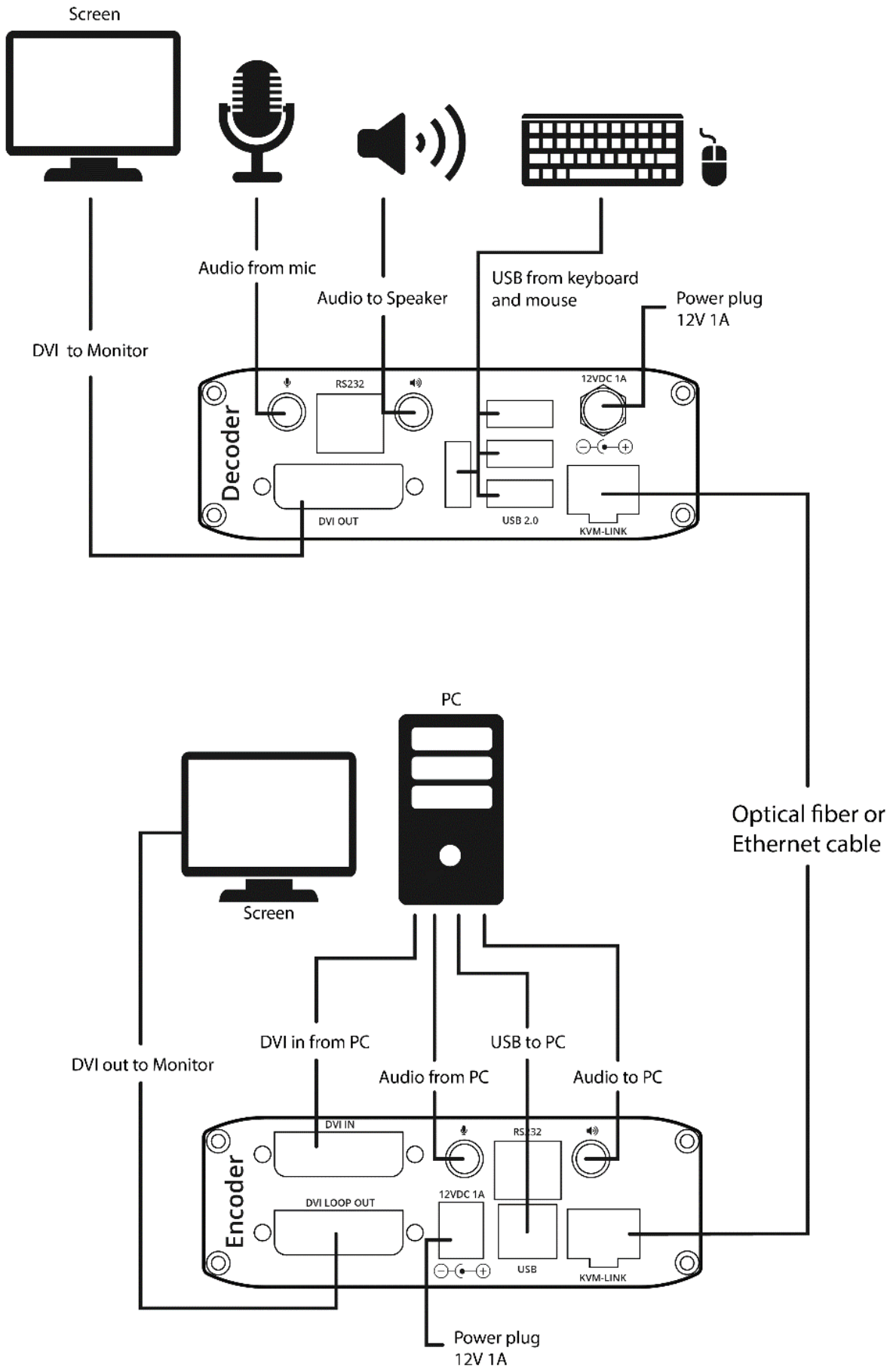

Quick start



If you're setting up a network with multiple endpoints, for best results connect just a few Pathfinder devices at a time, and then add them to Pathfinder Control and update the firmware before you move on to the next set. This makes it much easier to find, name, and connect your devices.

Connecting your hardware

1. Connect the USB-A port on your PC to the USB-B port of the encoder.
2. Connect a keyboard and mouse to the decoder.
3. Connect the PC video output to the DVI In port of the encoder.
4. Connect the encoder and the decoder with fiber optical or Ethernet cable.
Or
Connect all endpoints to a network switch. Ensure that all connections have a bandwidth of 1 Gbit/sec minimum.
For video sharing the network switch must support IGMP snooping, and IGMP snooping must be switched on.
5. Connect the remote monitor to the decoder with HDMI-DVI.
6. OPTIONAL: use a 3.5 mm jack to connect the  port of the encoder to a speaker, or to the mic port of your PC. Connect the  port of the encoder to the headphone port of your PC.
7. OPTIONAL: use a 3.5 mm jack to connect the  port of the decoder to a speaker. Connect the  port to a microphone.
8. Switch on your PC and monitors.
9. If you're using a network switch, connect the power supply to an electrical outlet.
10. Connect the encoder and decoder to electrical outlets with the included 12 V 1 A power supplies. Your Pathfinder devices start.

Setting up your system in Pathfinder Control

-  If your Pathfinder network includes a network switch, Pathfinder Control must run on your Pathfinder network at all times. You don't have to be logged in.

Use Pathfinder Control to set up your system and upgrade your firmware.

To set up your system in Pathfinder Control

i This task is for administrators.

1. Install Pathfinder Control on a dedicated PC connected to the Pathfinder network. Download Pathfinder Control from tvone.com/tech-support/software.
2. Open Pathfinder Control and log in as an administrator. The default username is `admin`, and the default password is `admin`.
3. Select General Settings.

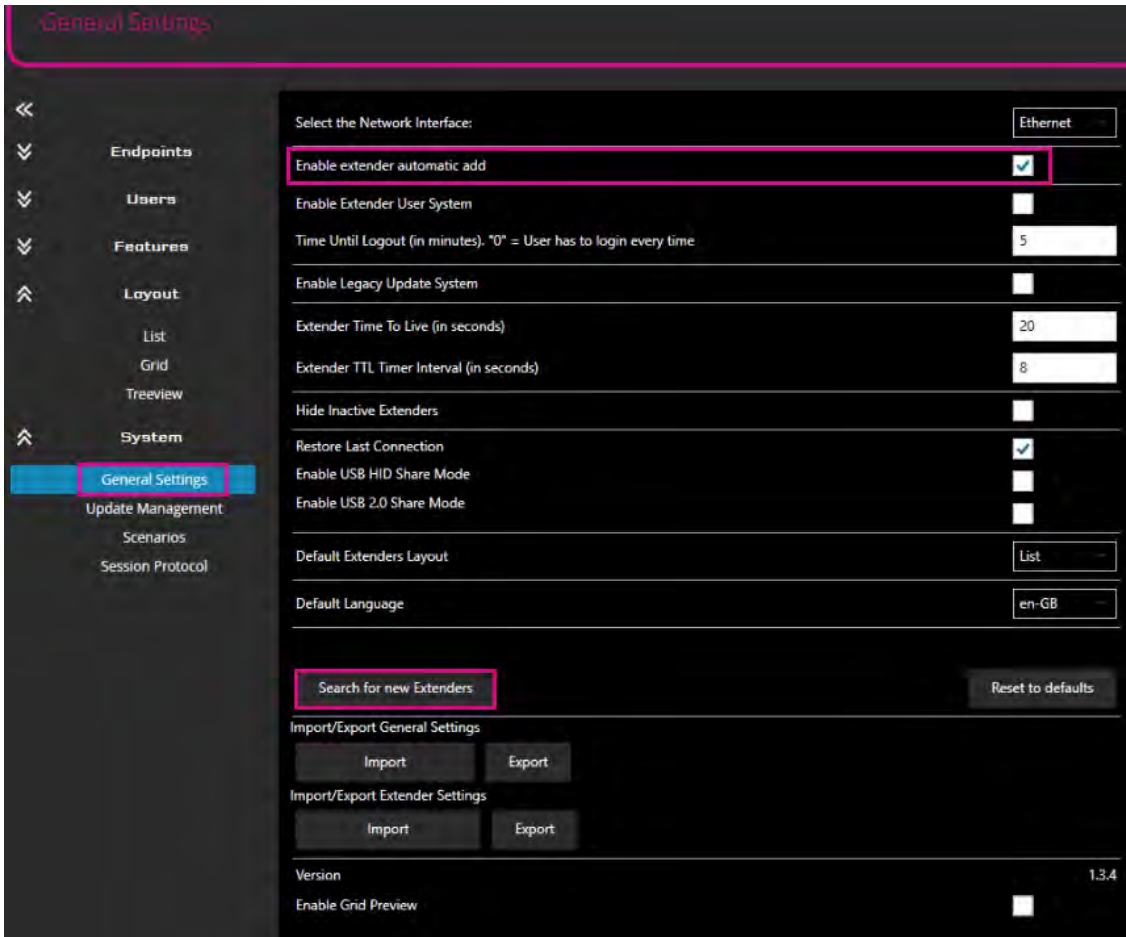

4. Make sure **Enable extender automatic add** is selected. If it isn't, select it, then save. Pathfinder Control closes. Open it again.
5. Optional settings:
 - If you want users to be able to use the on-screen display to connect to and disconnect from devices, or share their connection with other users, select **Enable Extender User System**. Users can only log in to devices they are bound to.
 - If you want users to be logged out of an on-screen display after a set time, enter a time in minutes in **Time Until Logout**. If you want users to have to log in every time they open the on-screen display, enter a time of 0 minutes.
 - If you want your network to automatically log off inactive devices:
 - Choose how often your network checks for inactive devices. Enter the time in seconds in **Extender TTL Timer Interval**.
 - Choose how long the network waits to hear from the device. Enter the time in seconds in **Extender Time To Live**.

- If you want devices that are not currently connected to the network to be hidden in Layout > List, select **Hide Inactive Extenders**.
 - If you want to restore the last connections made between encoders and decoders when the software starts, select **Restore Last Connection**.
Note: this setting also re-connects any devices that lost power or are powered off when power returns.
 - If you want users to be able to share control of their connection as well as their video signal, select **Enable USB HID Share Mode** or **Enable USB 2.0 Share Mode**.
 - You can choose the default layout view. Select your layout from **Default Extenders Layout**.
6. Select your language from **Default Language**.
 7. Select **Search for new Extenders**.
 8. Select **Endpoints > Extender Settings**.
 9. Double-click each extender and give it a name.

Updating your firmware

1. Download the latest firmware from tvONE.com/tech-support/software.
2. In Pathfinder Control, select **System > Update Management**.

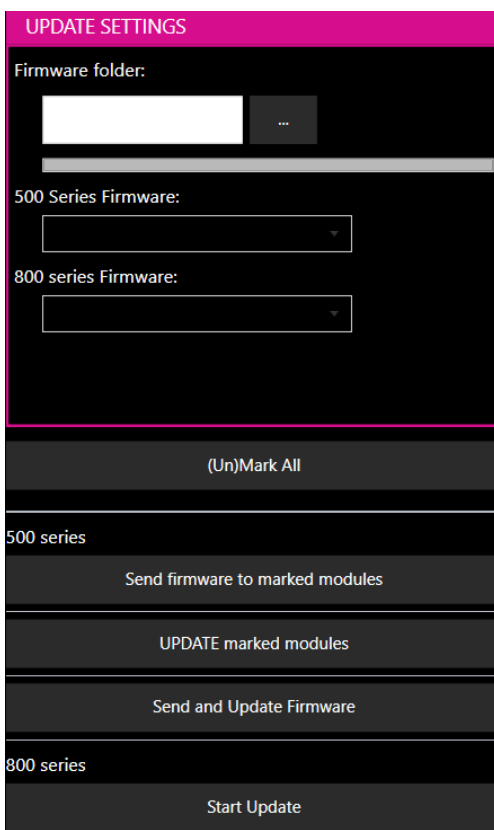

3. In **UPDATE SETTINGS**, select **...** and navigate to the firmware file you downloaded in step 1. The firmware .bmp file appears under **500 Series Firmware:**.
4. Select **(Un)Mark All** to select all the devices on your network.
5. Select **Send and Update Firmware**.
Your devices update. When the firmware update is complete, **Finished!** appears under **Alerts**.

- If **Error! Try again!** appears, restart the device or devices that did not update.
- If that doesn't work, repeat the steps above.

You can now add your next batch of devices. Start again from **To set up your system in Pathfinder Control** on page 10.

Connecting encoders and decoders in Pathfinder Control

This task is for systems with multiple endpoints only. If you're only extending a single PC, skip this task and go to **The on-screen display – the Home menu** on page 13.

1. Select **Layout > List**.
2. For the devices you want to connect, select the box in the **Grid** column. If you don't want to connect a device right now, clear the box in the **Grid** column.
3. Select **Layout > Grid**.
4. From **Decoders**, select a decoder. When the decoder turns green, select an encoder from **Encoders**. When the two devices are connected, they turn blue.

Next steps

Congratulations, your basic network is set up. You can now log on to and use your Pathfinder network with just the on-screen display.

Read on for information about how users can log on to a PC and connect to an encoder.

You can also set up more sophisticated features in Pathfinder Control, such as device groups, Cross-Click, and WindowView.

Read more about setting up extra features in the User Guide. Download the User Guide from help.tvone.com/products/mg/mg-kvm.

The on-screen display – the Home menu

Opening the on-screen display

To open the on-screen display, press Scroll Lock (ScrLk) quickly five times.

✓ If your keyboard doesn't have a Scroll Lock key, open the on-screen keyboard.
Select Start > Settings > Ease of Access > Keyboard.

The Home menu

The Home menu includes a list of sub menus and your current firmware version. Update your firmware with Pathfinder Control software.

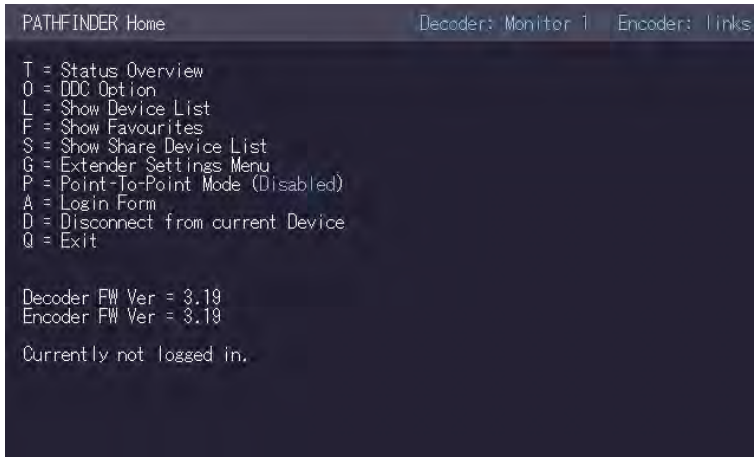

T	Status Overview	Menu status / current status
U	Update Flash FW	Update firmware
O	DDC Option	Set your DDC/EDID
W	Network Settings	Network settings
G	Extender Settings	Encoder and decoder settings
L	Show Device List	List of all pathfinder devices on the network
Q	Exit	Exit

Connecting and disconnecting with the on-screen display

Use the monitor and keyboard connected to your decoder to open the on-screen display. The on-screen display opens displaying the Home menu.

Opening the on-screen display

To open the on-screen display, press Scroll Lock (ScrLk) quickly five times.

- ✓ If your keyboard doesn't have a Scroll Lock key, open the on-screen keyboard.
Select Start > Settings > Ease of Access > Keyboard.

Using keyboard shortcuts

You can use keyboard shortcuts even if the on-screen display is closed, for example, to connect to a favorite encoder. If you use a keyboard shortcut when the on-screen display is closed, the shortcut is also sent to the PC you are connected to.

When you use Cross-Click or WindowView to work across multiple PCs, the shortcut is sent to the PC you are currently working on.

Read about viewing and changing keyboard shortcuts on page 23.

Connecting and disconnecting

To log in to a PC

1. Open the on-screen display.
2. In the Home menu, press A.
3. Enter your username and password.

To connect to an encoder

1. Open the on-screen display.
2. In the Home menu, press L.
3. In the Device List menu, find the encoder you want to connect to, and press the number button for that encoder.



If your network has many endpoints, but you only use a few of them regularly, you might want to set up a list of favorites.

Read more about favorites on page 16.

To disconnect from an encoder

1. Open the on-screen display.
2. In the Home menu, press D.

To open a point-to-point connection

If you are not connected through a network switch, you can connect directly to an encoder in point-to-point mode.

1. Open the on-screen display.
2. In the Home menu, press P.

Searching in a list

Several menus of the on-screen display show lists. If the menu shows [TAB] – insert into filter, you can search in the list.

- To search in the list, press TAB, enter the first few letters of a device name, and press Return.

Managing devices with the on-screen display

Opening the on-screen display

To open the on-screen display, press Scroll Lock (ScrLk) quickly five times.

- ✓ If your keyboard doesn't have a Scroll Lock key, open the on-screen keyboard.
Select Start > Settings > Ease of Access > Keyboard.

Getting information about your status

To open the Status menu, in the Home menu, press T.

The Status menu also appears on your monitor when you are not connected to an encoder. You can turn off this feature.

Read more about hiding the Status menu on page 23.

The Status menu shows the current status of your connection. It provides information on the connection itself, resolution of the video channel, and the status of the USB.



- Enabled options and the current firmware version are displayed in the left top section.
- LINK shows whether there is a physical connection available.
- VIDEO and USB show if data is currently being transmitted.

Choosing and using favorite devices

Each user can save up to eight favorite devices assigned to shortcut keys. Assign favorite devices in the Device List menu.

To choose a favorite device



1. To open the Device List menu, in the Home menu, press L.
2. Use the arrow keys to select your favorite device.
3. Press a key from F1 to F8.

To view your list of favorite devices

View your list of favorite devices in the Favorite List menu. To open the Favorite List menu, in the Home menu, press F.



To connect to a favorite encoder

1. Log in to your account. In the Home menu, press A, and then enter your username and password.
2. Press Ctrl+Alt+F#, where F# is the F key you assigned to the favorite encoder.

Sharing your connection with another user

You can share your connection with another user in two ways: push and get. When you push, you allow another user to view your connection. When you get, you ask another user to show their connection to you.

Share connections with the Share Device Push and Share Device Get menus. To open either menu, in the Home menu, press S.

The on-screen display remembers which menu you chose last time.

To switch between the Share Device Push and Share Device Get menus

- In the Share Device Push menu, press G.
- In the Share Device Get menu, press P.

To push your connection to another user

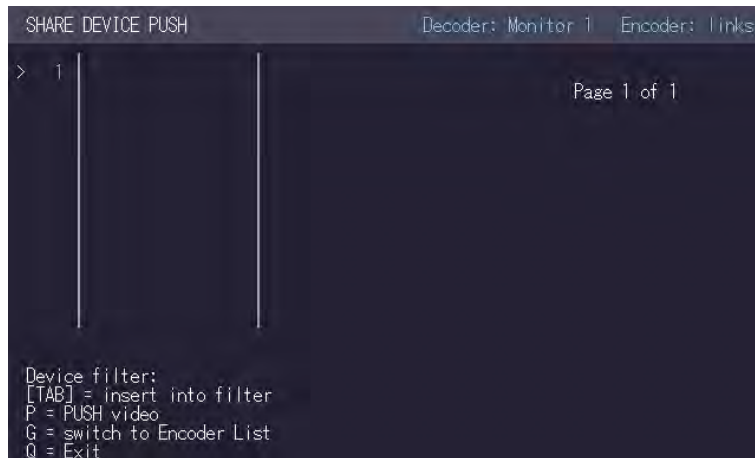

1. In the Home menu, press S.
2. If you arrive at the Share Device Get menu, press P.
3. In the Share Device Push menu, use the arrow keys to navigate to the decoder of the user you want to view your connection.
4. Press Enter.

To view another user's connection

1. In the Home menu, press S.
2. If you arrive at the Share Device Push menu, press G.
3. In the Share Device Get menu, use the arrow keys to navigate to the decoder of the user whose connection you want to view.
4. Press Enter.

To control another user's PC

Normally you only view another connection. You can control the PC as well if the other user enables the USB Share any Key option. If the other user enables that option, press any key to start controlling their PC.

Read more about USB Share any Key on page 23.

You can take control of another user's PC even if they haven't enabled USB Share any Key. When you view a connection, press Ctrl twice, quickly.

Managing settings with the on-screen display

Opening the on-screen display

To open the on-screen display, press Scroll Lock (ScrLk) quickly five times.

- ✓ If your keyboard doesn't have a Scroll Lock key, open the on-screen keyboard.
Select Start > Settings > Ease of Access > Keyboard.

Defining what DDC or EDID data your PC uses

To open the DDC/EDID Settings menu, in the Home menu, press O.

The DDC/EDID Settings menu allows you to define what DDC information is used by the PC.

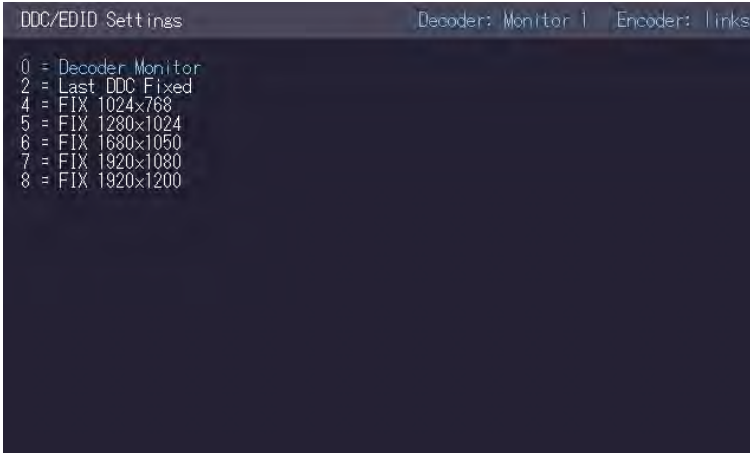

To define what DDC information is used by the PC:

1. In the Home menu, press O.
2. Choose which DDC or EDID information your PC uses.
 - Press 0 to use the DDC information from the monitor attached to the decoder.
 - Press 2 to save the current DDC information. The system uses the same settings after the extender has been restarted.
 - Press 4 through 8 to use a predefined resolution which is saved.
3. Press Esc to return to the Home menu.

Managing encoder settings

Make changes to your encoder settings in the KVM Settings > Encoder menu.

To open the KVM Settings > Encoder menu, in the Home menu press G > L.



- To make changes to your display settings, press V.
Read more on page 19.
- To allow a user to wake up the PC remotely by moving their mouse, enable USB remote wakeup.
Press W.

- To make your encoder work with Linux, press L.
- To make your keyboard and mouse work with older devices that do not support USB 2.0, press E.

Changing your display settings

You can change your display settings in the **VGA Parameters** menu. In the **Home** menu, press **G > L > V**.

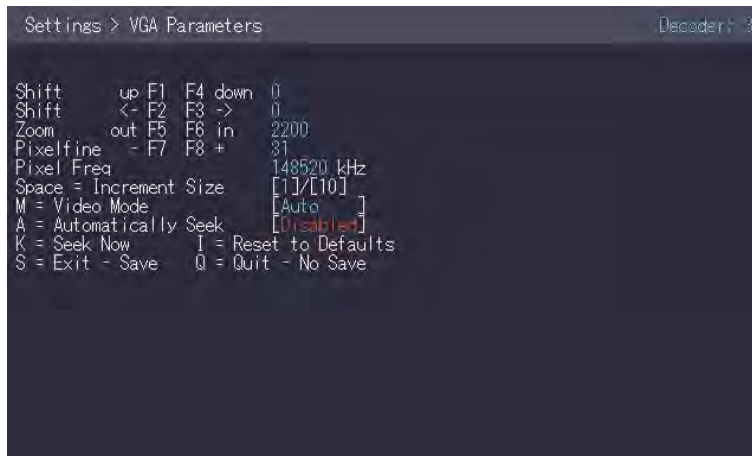

- Press F1 to move the display area up.
- Press F4 to move the display area down.
- Press F2 to move the display area to the left.
- Press F3 to move the display area to the right.
- Press F5 to zoom out.
- Press F6 to zoom in.
- Press Space to change the rate of the above settings. Toggle the rate of change between 1 and 10.
- Pixel Freq is read-only.
- Press M to switch the video mode between:
 - Auto – the mode is automatically detected and set by the extender.
 - DVI – only DVI input is detected.
 - VGA – only VGA input is detected.
- Press K for automatic adjustment and positioning of the image area.
- Press L to reset parameters to default values.
- Press S to save the settings and exit the menu.
- Press Q to exit without saving.

Managing decoder settings

Make changes to your decoder settings in the KVM Settings > Decoder menu. In the Home menu press G > R.

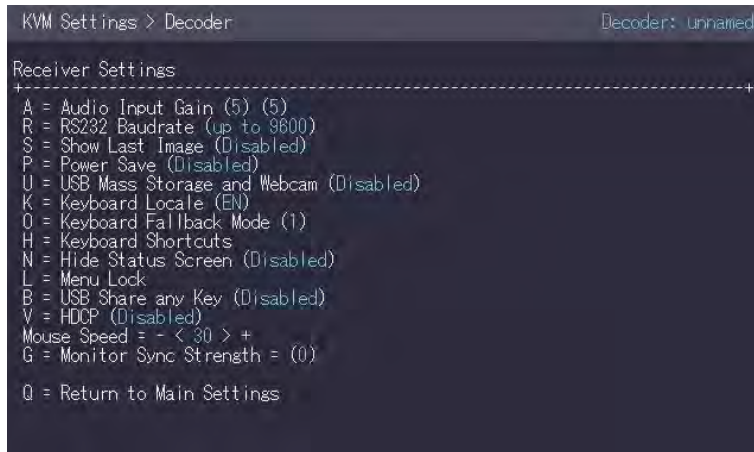

Setting the audio volume

The volume of the audio input and output on the decoder unit can be changed in the Audio Volume menu. In the Home menu, press G > R > A.



The default value is 5 but can be set to any value in between 0 and 9. At 0 the audio input on the decoder unit is muted.

Press arrow left / right to change volume. Press arrow up / down to choose between audio input and audio output.

Setting a baud rate for your RS-232 connection

Set a baud rate in the RS232 menu. In the Home menu, press G > R > R.

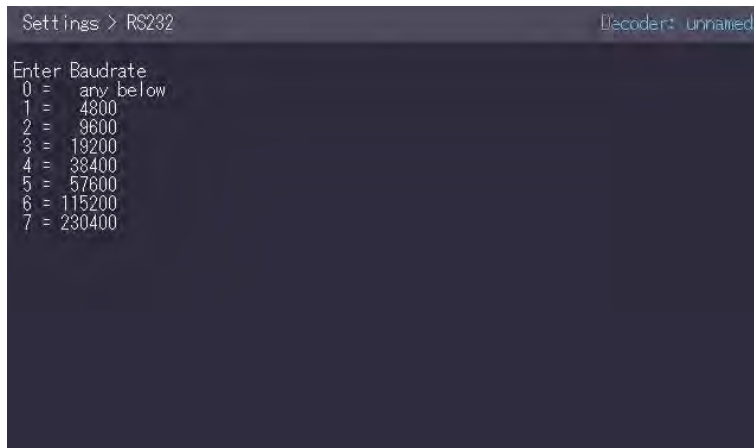

1. Press 0-7 to select a baud rate.

2. Select an appropriate parity.



3. Select 1 or 2 stop bits.

Choosing what to show on the decoder monitor when there is no connection

You can choose what to show on the monitor connected to the decoder when the encoder and decoder are disconnected, or the decoder is not in use.

Choose what to show on the monitor in the **KVM Settings > Decoder** menu. In the Home menu press **G > R**.

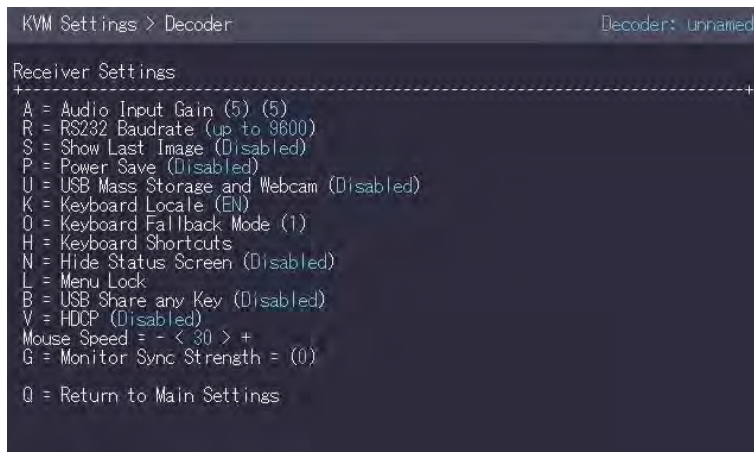

Press **S** to enable or disable the show last image feature.

- If the show last image feature is disabled, the monitor shows a black screen.
- If the show last image feature is enabled, the monitor shows the last image received before disconnection.

When you choose to show the last image received, the image has a flashing red border.

Power save mode

You can choose to enter power save mode if the decoder doesn't receive anything from the encoder for more than a minute.

If your decoder is set to show the last image received when it becomes disconnected, the monitor shows the last image for one minute, and then enters power save mode.

To return from power save mode, press any key.

Enable and disable power save mode in the **KVM Settings > Decoder** menu. In the **Home** menu press **G > R**.

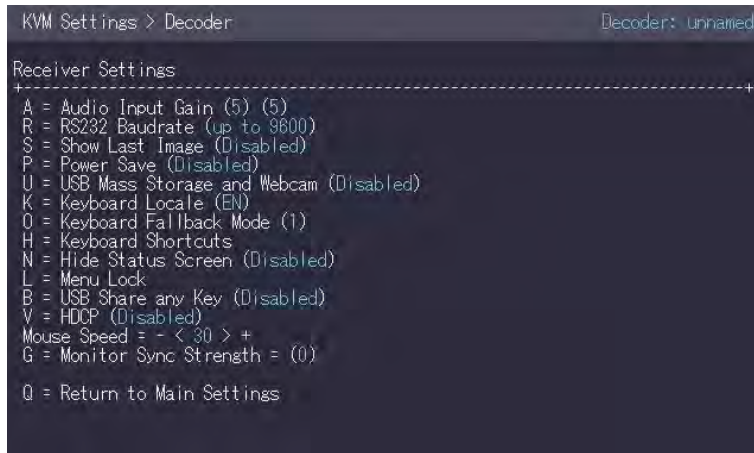

Protecting your PC from viruses from a USB drive

To protect your PC from viruses, you can prevent your decoder from sending information from USB drives to an encoder. To disable USB drives and webcams, set **USB Mass Storage and Webcam** to **Disabled**. In the **Home** menu, press **G > R > U**.

The **USB Save Feature** option does not prevent you from updating your firmware with a USB drive.

- You can't lock the **USB Save Feature** option.
- ! ▪ You can lock the on-screen display with a password or with a timeout time.
Read about locking the on-screen display on page 23.

Selecting QWERTY, AZERTY, or QWERTZ keyboard layout

The **Keyboard Locale** menu lets you switch between keyboard layouts for navigating the on-screen display. You can choose between French (**AZERTY**), English (**QWERTY**), and German (**QWERTZ**).

Select a keyboard layout in the **Keyboard Locale** menu. In the **Home** menu, press **G > R > K**.

- Press **E** to select English (**QWERTY**)
- Press **D** to select German (**QWERTZ**)
- Press **F** to select French (**AZERTY**)

Changing keyboard fallback mode

To use the on-screen display, the decoder needs to identify your keyboard. The keyboard fallback mode helps your decoder do this. Set the keyboard fallback mode in the **KVM Settings > Decoder** menu. In the **Home** menu press **G > R**.

Most keyboards use setting 0. Some USB mice behave like a keyboard. In this case select fallback mode 1 or 2.

Changing your keyboard shortcuts

You can change the keyboard shortcuts for common commands.

Edit shortcuts in the Keyboard Shortcuts menu. In the Home menu, press G > R > H.

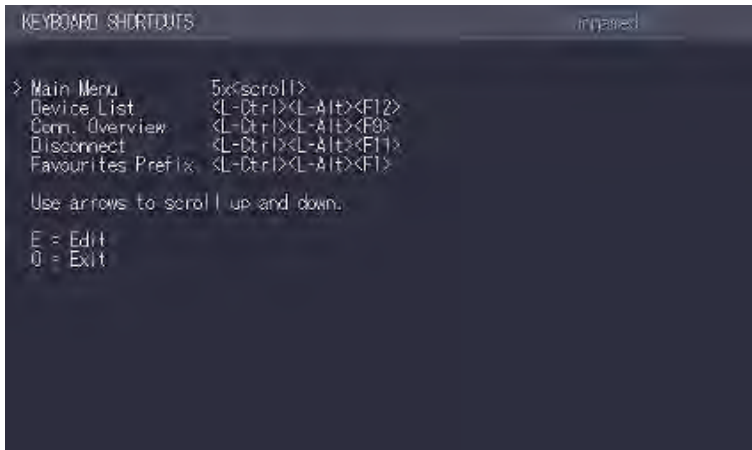

1. Use the arrow keys to select a command.
2. Press E to edit the shortcut.
 - For keyboard shortcuts, press your new key combination.

Hiding the status menu

When you are not connected to a PC, your monitor shows the Status menu. You can choose to hide the Status menu. When the Status menu is hidden, your monitor just shows a black screen.

Hide the Status menu in the KVM Settings > Decoder menu. In the Home menu, press G > R.

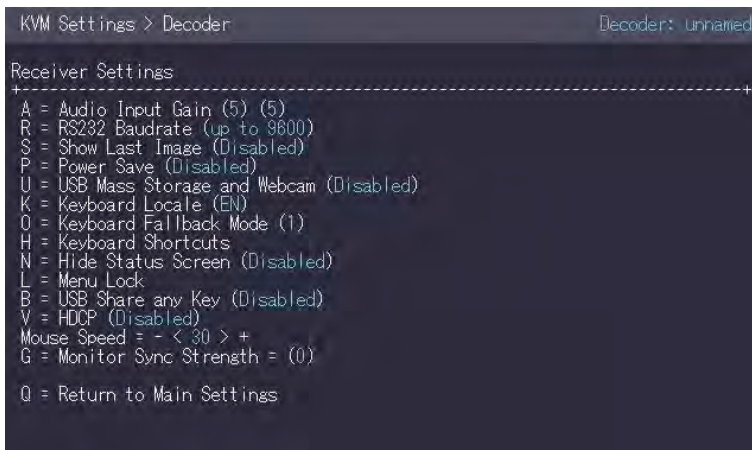

- To hide the Status menu, press N.

Locking the on-screen display

You can lock the on-screen display in two ways: by timeout, or by password. If you set a timeout time, users, including admins, can't access the on-screen display after the timeout time. To access the on-screen display, restart the decoder. You have 60 seconds to disable the lock.

If you set a password, only users with the password can access the on-screen display.

Risk of losing access to the on-screen display

- ! If you lock the on-screen display with a password and then lose the password, you can't reset the decoder yourself. Contact your distributor for help.

Lock the on-screen display in the Menu Lock menu. In the Home menu, press G > R > L.

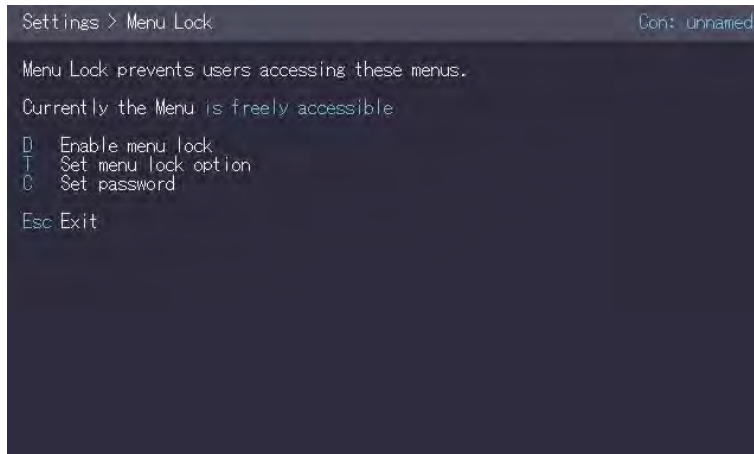

- To choose a timeout time or select lock with password, press T.
- To enter a password, press C.
- To enable or disable the lock, press D.

Enabling other users to control your PC when you share your connection

You can allow a user sharing your connection to control your PC. Enable USB Share any Key in the KVM Settings > Decoder menu. In the Home menu, press G > R.

Enabling HDCP protected video

HDCP protected video content is only supported on Pathfinder 500 series devices. If your PC or monitor is connected to a Pathfinder 800 series device, no video appears. All Pathfinder 500 series decoders must have HDCP enabled for you to receive HDCP content.

To receive HDCP protected video, enable HDCP. Enable HDCP in the KVM Settings > Decoder menu. In the Home menu, press G > R.

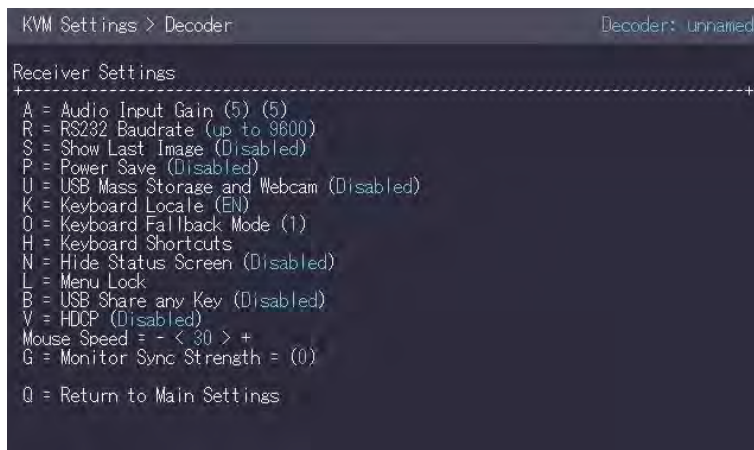

- To enable HDCP, press V.

Reducing video tearing with monitor synchronization

You can reduce the effects of video tearing with monitor synchronization. The default value is 0. Start at the lightest setting, 1. If that doesn't work, increase synchronization to 2 or 3.

Choose a level of monitor synchronization in the **KVM Settings > Decoder** menu. In the **Home** menu, press **G > R**.

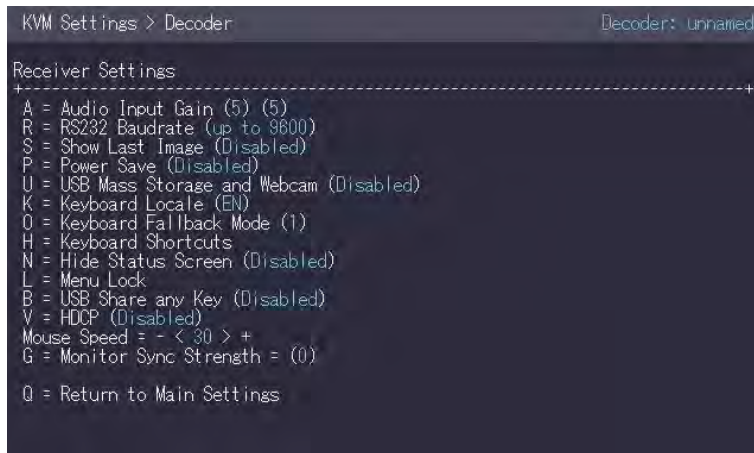

- To cycle through the levels of monitor synchronization, press G.

Network settings and more

Manage network settings, user administration, and device settings in Pathfinder Control software. Read about Pathfinder Control in the User Guide. Download the User Guide from help.tvone.com/products/mg/mg-kvm.

Troubleshooting and FAQs

Updating your firmware

1. Download the latest firmware from tvone.com/softwares.
2. In Pathfinder Control, select **System > Update Management**.

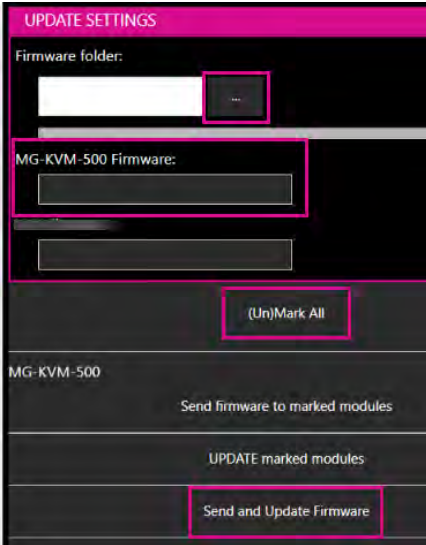

3. In UPDATE SETTINGS, select ●●● and navigate to the firmware file you downloaded in step 1. The firmware .bmp file appears under MG-KVM-500 Firmware.
4. Select (Un)Mark All to select all the devices on your network.
6. Select Send and Update Firmware.
Your devices update. When the firmware update is complete, **Finished!** appears under Alerts.
 - If **Error! Try again!** appears, restart the device or devices that did not update.
 - If that doesn't work, repeat the steps above.

No power is getting to my Pathfinder device

The status LED light is not lit.

- ✓ Check the power supply is connected and plugged in.
- ✓ Try a different power supply.

My USB keyboard or mouse isn't working

The status LED light is green or blinking green.

- ✓ Check the keyboard or mouse is connected correctly.
- ✓ Disconnect the keyboard or mouse. Reconnect the keyboard or mouse. Wait for drivers to install or update.
- ✓ Check the USB port of the encoder is connected to the PC.
- ✓ Check the keyboard or mouse works correctly when connected directly to a PC.
- ✓ Try a different USB cable.
- ✓ Check that the encoder and decoder are running the latest firmware.
- ✓ Try a different encoder and decoder.
- ✓ Try a different keyboard fallback mode.

- ✓ If the LED status light is blinking green, your USB keyboard or mouse might not be compatible.

No video is reaching the monitor connected to the decoder

The LED status light is red or orange.

- ✓ Check all cables are connected correctly.
- ✓ Connect a monitor directly to the PC and check for signal.
- ✓ Check that the DDC or EDID is correct.
- ✓ Try adjusting the resolution of the monitor.
- ✓ Check that the encoder and decoder are running the latest firmware.

The LED status light is green.

- ✓ Try enabling HDCP. In the on-screen display, press G > R > V.

Video is poor quality or stripy

The LED status light is green.

- ✓ Check all cables are connected correctly.
- ✓ Connect a monitor directly to the PC and check video quality.
- ✓ Check that the DDC or EDID is correct.
- ✓ Check that the encoder and decoder are running the latest firmware.
- ✓ Check the network switch. Is it set up correctly? Is there enough bandwidth?
- ✓ Check other units for the same behavior.

I can't hear any audio

The status LED light is green.

- ✓ Check all cables are connected correctly.
- ✓ Connect an audio playback device to the encoded PC and check the signal.
- ✓ Connect a mic to the encoded PC and check the signal.

General troubleshooting checklist

If specific troubleshooting advice isn't helping, or your product has stopped working, go through the points below. If your product still doesn't work, you might need to return it for repair.

1. Make sure your product is set up correctly, as shown in this guide.
2. Check that your cables and equipment are all connected firmly.
3. Check that your product is connected to an electrical outlet that is switched on.
Can you see LED lights on the front of your product?
4. Test your sources by connecting them directly to a display.
5. Test your display by connecting it directly to a source.
6. Test each cable.
7. Try restoring your product to factory default settings.
Note: during factory reset your custom settings are deleted.

8. Try updating your firmware.

Note: during a firmware update your custom settings are deleted.

Returning a product for repair

You can request to return your product to tvONE™ for repair. When you contact tvONE support, have the following information ready.

- Product type
- Serial number of the faulty unit (this is on the underside of the unit)
- Full details of the issue
- Invoice number (if available)

Contact tvONE support for your area.

- Customers in North, Central, and South America (NCSA), email tech.usa@tvone.com.
- Customers in Europe, the Middle East, and Africa (EMEA), email tech.europe@tvone.com.
- Customers in Asia, email tech.asia@tvone.com.

EMEA and Asia

Customers in EMEA and Asia receive an RMA Request form from tvONE support. Complete the form and return it to tvONE support for your area.

All customers

tvONE support decides if your product needs to return for repair, and, if needed, provide a return authorization number.

Send your product to tvONE by insured carrier or registered mail. Write your return authorization number on the outside of the packaging, and on any documents you send with your product.

You must arrange and pay for shipping and insurance. Products in transit are your responsibility. tvONE does not accept responsibility for products lost in transit.

! Do not return a product for warranty repair without a return authorization number. tvONE will not repair your product.

Contact us

tvone.com

info@tvone.com

Support NCSA: tech.usa@tvone.com

Support EMEA: tech.europe@tvone.com

Support Asia: tech.asia@tvone.com

Information in this document is subject to change without notice. No part of this publication may be reproduced, stored in a retrieval system, or transmitted in any form or any means electronic or mechanical, including photocopying and recording for any purpose other than the purchaser's personal use without the written permission of tvONE.

Copyright © 2019 tvONE™. All rights reserved.

Registered in the U.S. Patent and Trademark Office.