

peerless-AV™

MOD-ADF

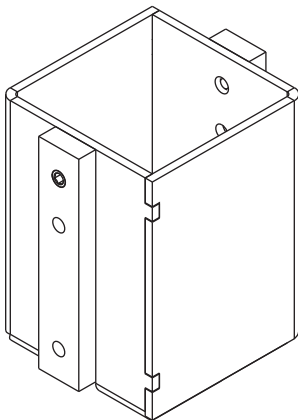

| |
|-----|
| ENG |
| ESP |
| FRN |
| DEU |
| NEL |
| ITL |
| ČEŠ |
| SLK |
| POR |
| TÜR |



| | |
|-----|--|
| ENG | Tools Needed for Assembly. |
| ESP | Herramientas necesarias para el ensamblaje. |
| FRN | Outils nécessaires au montage. |
| DEU | Für den Zusammenbau erforderliche Werkzeuge. |
| NEL | Voor montage benodigd gereedschap. |
| ITL | Attrezzi necessari per l'assemblaggio. |
| ČES | Nástroje potřebné k montáži. |
| SLK | Nástroje potrebné na montáž. |
| POR | Ferramentas necessárias para a montagem. |
| TÜR | Montaj İçin Gerekli Aletler. |

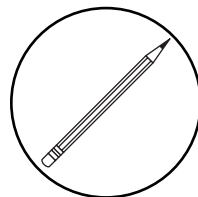
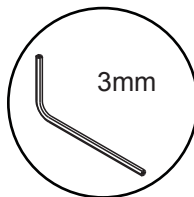
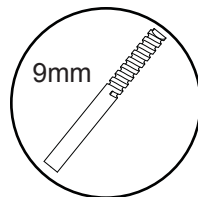
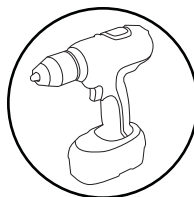

| | |
|-----|---|
| ENG | Parts (Before beginning, make sure you have all parts shown below). |
| ESP | Piezas (antes de iniciar, asegúrese de tener todas las piezas siguientes). |
| FRN | Pièces (avant de commencer, assurez-vous d'avoir toutes les pièces illustrées ci-dessous). |
| DEU | Teile (Achten Sie vor Beginn der Arbeiten darauf, dass alle unten abgebildeten Teile vorhanden sind). |
| NEL | Onderdelen (hoort u zich ervan te overtuigen dat u alle onderdelen hebt, die hieronder te zien zijn). |
| ITL | Parti (prima di iniziare, accertarsi di disporre tutte le parti sotto indicate). |
| ČES | Díly (předtím, než začnete, připravte si všechny díly zobrazené níže). |
| SLK | Diely (predtým, ako začnete, pripravte si všetky diely zobrazené nižšie). |
| POR | Peças (antes de iniciar, certifique-se de que tem todas as peças apresentadas em baixo). |
| TÜR | Parçalar (Başlamadan önce, aşağıda gösterilen bütün parçaların elinizde olduğundan emin olun). |

Parts List

| Description | Qty. | Part # |
|----------------------|------|----------|
| A drill template | 1 | 100-1053 |
| B M6 x 6mm set screw | 2 | 510-9150 |

A (1)

drill template

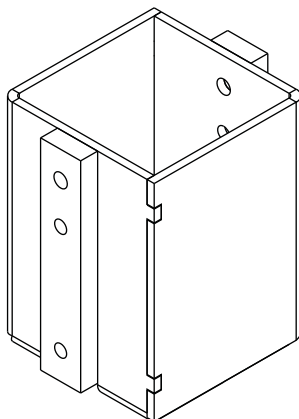

B (2)

M6 x 6mm



1-1

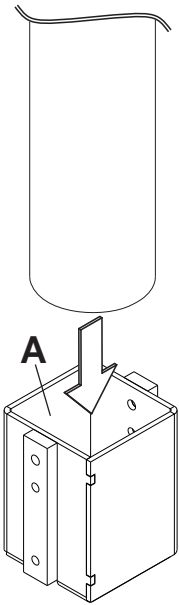

1-2

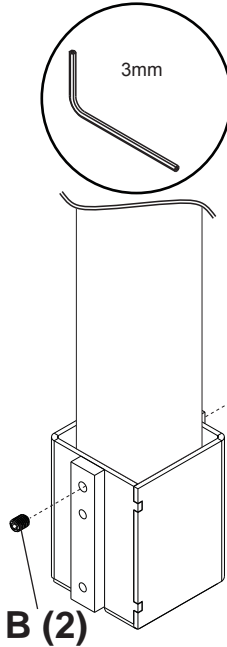

1-3

| | |
|-----|-----------------------------------|
| ENG | Mark drill holes. |
| ESP | Marque los orificios de montaje. |
| FRN | Marquez les trous de fixation. |
| DEU | Markieren Sie die Montagelöcher. |
| NEL | Markeer montagegaten. |
| ITL | Contrassegna i fori di montaggio. |
| ČES | Vyznačte montážní otvory. |
| SLK | Vyznačte montážne otvory. |
| POR | Marque os furos de montagem. |
| TÜR | Montaj deliklerini işaretleyin. |

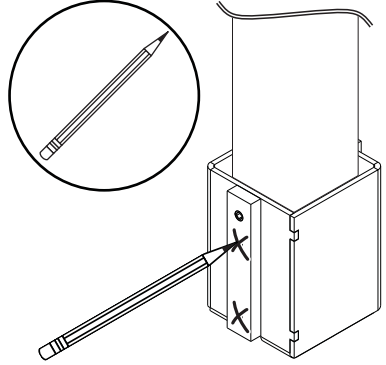

2

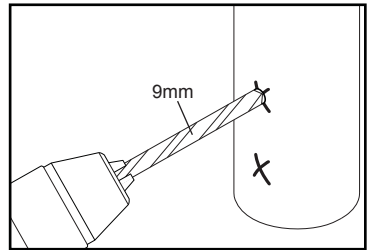
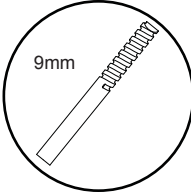

| | |
|-----|---|
| ENG | Remove tube from drill template. Drill mounting holes. |
| ESP | Quite el tubo de la plantilla. Perfere los orificios de montaje. |
| FRN | Retirez le tube du gabarit. Percez les trous de fixation. |
| DEU | Entfernen Sie das Rohr von der Schablone. Bohren Sie die Montagelöcher. |
| NEL | Verwijder de buis uit het sjabloon. Boor montagegaten. |
| ITL | Rimuovere il tubo dalla sagoma. Trapano i fori di montaggio. |
| ČES | Rimuovete il tubo dalla sagoma. Vyvrtejte montážní otvory. |
| SLK | Rimuovete il tubo dalla sagoma. Vyvrtajte montážne otvory. |
| POR | Retire o tubo do modelo. Perfure os furos de montagem. |
| TÜR | Boruyu şablondan çıkarın. Montaj deliklerini matkapla delin. |

| | |
|-----|--|
| ENG | Refer to accompanying instructions for additional information. |
| ESP | Consulte las instrucciones que se acompañan de información adicional. |
| FRN | Reportez-vous aux instructions d'accompagnement pour des informations supplémentaires. |
| DEU | Siehe begleitende Hinweise für weitere Informationen. |
| NEL | Raadpleeg de bijbehorende instructies voor meer informatie. |
| ITL | Fare riferimento alle istruzioni di accompagnamento per ulteriori informazioni. |
| ČES | Viz doprovodné pokyny pro další informace. |
| SLK | Pozri sprievodné pokyny pre ďalšie informácie. |
| POR | Consulte as instruções que a acompanham para informações adicionais. |
| TÜR | Ek bilgi için ekteki talimatlara bakın. |

peerless-AV™

Peerless-AV
2300 White Oak Circle
Aurora, IL 60502
Email: tech@peerlessmounts.com
Ph: (800) 865-2112
Fax: (800) 359-6500
www.peerless-av.com

© 2012, Peerless Industries, Inc.