

PJF3-UNV(-W)
PJF3-EXA/-EXB/-EXC(-W)



Max load
55lb (24.9kg)

SMARTMOUNT.

Projector Mount

FOR FLUSH OR EXTENDED APPLICATIONS

Peerless-AV's PJF3 Projector Mount is loaded with an array of new features to enhance your viewing experience. The PJF3's tool-less height and image adjustment and quick-release mechanism provide easy setup and projector maintenance. In addition to a flush mount the PJF3 series comes in three different extension lengths, allowing the projector to be placed anywhere between 13" to 43" from the ceiling. The PJF3-EXA/B/C(-W) all come with internal cable management, ensuring a clean, clutter-free and professional installation.

PJF3's tool-less height and image adjustment feature provides quick setup and simple projector maintenance.



Additional Features

- ✓ Fits projectors up to 55lb (24.9kg)
- ✓ Quick-release mechanism to easily service projector
- ✓ Internal cable management protects, contains and conceals cables for a clean, professional installation
- ✓ Alternative cable management provided through center of ceiling plate
- ✓ Cosmetic cover with cable management knockouts for simple cable management
- ✓ Spider® Universal Adaptor Plate extends up to 17.63" (448mm) to fit most projector models
- ✓ Tool-less height and image adjustment provided for quick setup and simple maintenance versatility
- ✓ ±20° Pitch
±10° Roll
360° Swivel (during installation)

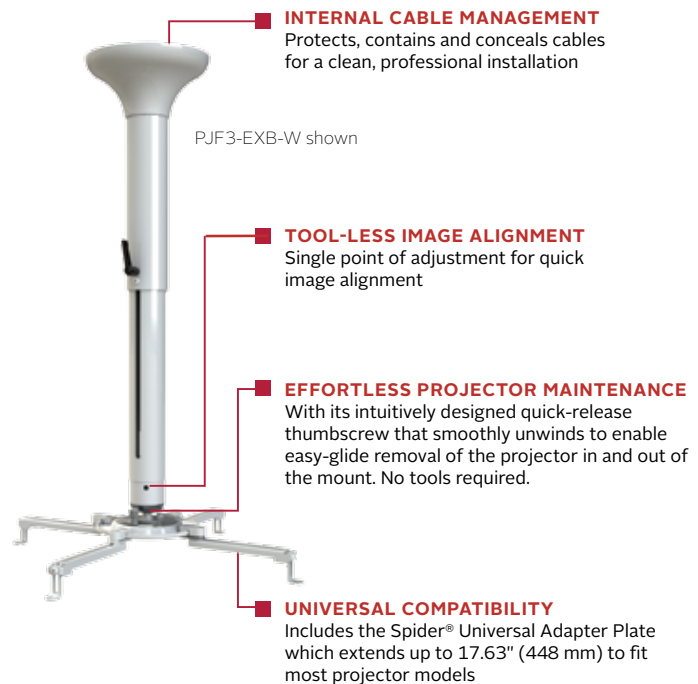

PJF3-UNV-W shown



PJF3-EXB shown



Internal cable management



info@peerless-av.com
peerless-av.com

peerless-AV®

PJF3-UNV(-W)	SmartMount® Projector Mount for flush application
PJF3-EXA(-W)	SmartMount® Projector Mount for extended applications with 13.00"-18.00" (330-457mm) height adjustment
PJF3-EXB(-W)	SmartMount® Projector Mount for extended applications with 18.00"-27.00" (457-686mm) height adjustment
PJF3-EXC(-W)	SmartMount® Projector Mount for extended applications with 27.00"-43.00" (686-1092mm) height adjustment

Product Specifications

	DIMENSIONS (W x H x D)	PRODUCT WEIGHT	LOAD CAPACITY	FINISH	AVAILABLE COLORS
PJF3-UNV(-W)	17.63" x 4.50"-5.50" x 17.63" (448 x 114-140 x 448mm)	2.4lb (1.09kg)	55lb (24.9kg)	Powder Coat	PJF3-UNV Black PJF3-EXA/-EXB/-EXC: Black PJF3-UNV -W: White PJF3-EXA-W/-EXB-W/-EXC-W: White
PJF3-EXA(-W)	17.63" x 13.00"-18.00" x 17.63" (448 x 330-457 x 448mm)	4.0lb (1.82kg)			
PJF3-EXB(-W)	17.63" x 18.00"-27.00" x 17.63" (448 x 457-686 x 448mm)	5.0lb (2.27kg)			
PJF3-EXC(-W)	17.63" x 27.00"-43.00" x 17.63" (448 x 686-1092 x 448mm)	5.7lb (2.59kg)			

Package Specifications

	PACKAGE SIZE (W x H x D)	PACKAGE SHIP WEIGHT	PACKAGE UPC CODE	PACKAGE CONTENTS	UNITS IN PACKAGE
PJF3-UNV(-W)	9.00" x 6.63" x 8.13" (229 x 168 x 206mm)	3.1lb (1.41kg)	PJF3-UNV: 735029305651	Mount, mounting hardware & instructions. EXA, EXB & EXC models also include a ceiling plate cover.	1
PJF3-EXA(-W)	15.50" x 7.25" x 9.50" (394 x 184 x 241mm)	5.7lb (2.59kg)	PJF3-EXA: 735029305668 PJF3-EXB: 735029305675 PJF3-EXC: 735029305682		
PJF3-EXB(-W)	15.50" x 7.25" x 9.50" (394 x 184 x 241mm)	6.3lb (2.86kg)	PJF3-UNV-W: 735029305729 PJF3-EXA-W: 735029305736 PJF3-EXB-W: 735029305743 PJF3-EXC-W: 735029305750		
PJF3-EXC(-W)	23.75" x 7.25" x 9.50" (603 x 184 x 241mm)	7.7lb (3.50kg)			

All dimensions = inch (mm)

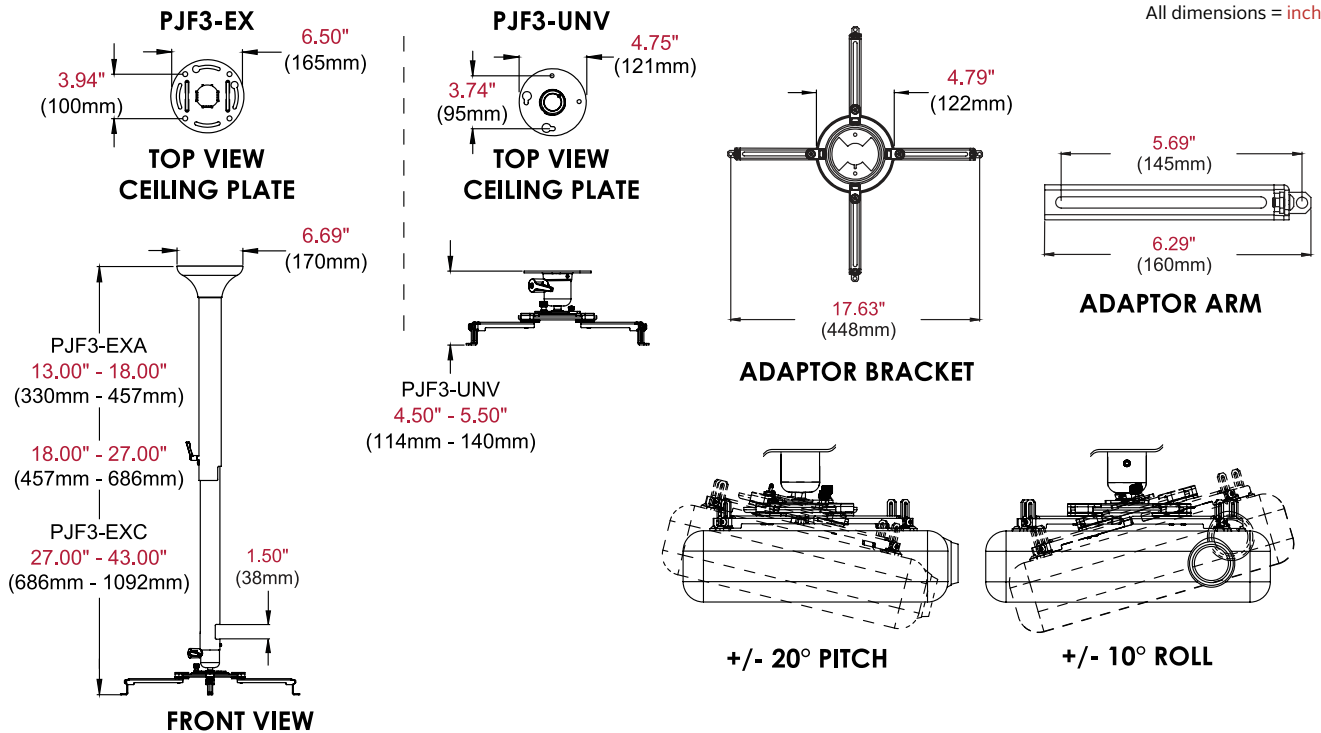

Architect Specifications

The Smartmount® Projector Mount shall be a Peerless-AV model PJF3-UNV(-W), PJF3-EXA(-W), PJF3-EXB(-W) or PJF3-EXC(-W) and shall be located where indicated on the plans. Assembly and installation shall be done according to instructions provided by the manufacturer.

Visit peerless-av.com to see the complete line of AV solutions from Peerless-AV, including outdoor displays, wireless, kiosks, digital audio, display mounts, projector mounts, carts/stands, and a full assortment of accessories.

Peerless-AV
2300 White Oak Circle
Aurora, IL 60502 USA

(800) 865-2112
(630) 375-5100
Fax: (800) 359-6500

Peerless-AV Europe
Unit 3 Watford Interchange
Colonial Way, Watford
Herts, WD24 4WP
United Kingdom
+44 (0) 1923 200100
Fax: +44 (0) 1923 200101

Peerless-AV de México
Ave de las Industrias 413
Parque Industrial Escobedo
Escobedo, N.L.,
Mexico 66050
+52 (81) 8384-8300
Fax: +52 (81) 8384-8360

