

PSTA-600  
PSTA-1200  
PSTA-1600



Max load  
25lb (11.3kg)

# Short Throw Projector Mounts

FOR PROJECTORS UP TO 25LB (11.3KG)

The PSTA series projector short throw kit is easily adjustable to accommodate ultra-short and short throw projector distance requirements. It includes the Peerless-AV Universal PRG-UNV Projector Mount that makes image alignment easy with three axis of adjustment.

*The PSTA Series of all-in-one solutions make finding your ideal projector placement effortless.*



## Additional Features

- ✓ Aluminum alloy telescoping arm with lock down slot
- ✓ Fully integrated cable management system conceals and protects cables for a clean finish
- ✓ Kitted with Peerless-AV PRG-UNV projector mount with precision gear alignment and adjustment knobs offering:
  - ±20° Pitch
  - ±10° Roll
  - 360° Swivel (during installation)
- ✓ Variable extension options:
  - PSTA-600: 16.73"-23.62" (425-600mm)
  - PSTA-1200: 29.72"-47.24" (755-1200mm)
  - PSTA-1600: 45.47"-63.00" (1155-1600mm)
- ✓ Fast and easy to install

**INTERNAL CABLE MANAGEMENT**  
Cable management access holes to route cables for a clean installation

**UNIVERSAL COMPATABILITY**  
Three models are three different lengths to cover all short throw projectors



**ALL-IN-ONE SOLUTION**  
Kitted with Peerless-AV PRG-UNV

Use our online **Short Throw Distance Calculator** at [projectorcalculator.peerless-av.com](http://projectorcalculator.peerless-av.com) to determine if a projector will work in your installation.



Patented. Design Patent No. D609,552; D597,582.



Cable Management

info@peerless-av.com  
peerless-av.com

peerless-AV®

- PSTA-600** Short Throw Projector Mount with arm length up to 23.62" (600mm)
- PSTA-1200** Short Throw Projector Mount with arm length up to 47.24" (1200mm)
- PSTA-1600** Short Throw Projector Mount with arm length up to 63.00" (1600mm)

**Product Specifications**

	DIMENSIONS (W x H x D)	PRODUCT WEIGHT	LOAD CAPACITY	FINISH	AVAILABLE COLORS
<b>PSTA-600</b>	9.60" x 9.60"-10.60" x 18.11"-25.00" (244 x 244-271 x 460-635mm)	8.5lb (3.8kg)			
<b>PSTA-1200</b>	9.60" x 9.60"-10.60" x 31.10"-48.60" (244 x 244-271 x 790-1235mm)	12.5lb (5.6kg)	25lb (11.3kg)	Aluminum alloy, powder coat	Black with Silver Arm
<b>PSTA-1600</b>	9.60" x 9.60"-10.60" x 46.85"-64.37" (244 x 244-271 x 1190-1635mm)	15.5lb (7.0kg)			

**Package Specifications**

	PACKAGE SIZE (W x H x D)	PACKAGE SHIP WEIGHT	PACKAGE UPC CODE	PACKAGE CONTENTS	UNITS IN PACKAGE
<b>PSTA-600</b>	21.00" x 12.00" x 11.00" (533 x 305 x 279mm)	10.5lb (4.7kg)	735029275749	Short throw arm, end cap, PRG-UNV, installation hardware, assembly instructions	1
<b>PSTA-1200</b>	32.50" x 12.00" x 11.00" (825 x 305 x 279mm)	14.5lb (6.5kg)	735029275756		
<b>PSTA-1600</b>	40.50" x 12.00" x 11.00" (1029 x 305 x 279mm)	17.5lb (7.9kg)	735029275763		

**Accessories**

- ACC020:** Projector Security Cable
- ACC215/415/615:** Metal Stud Fastener Kit
- IBA Models:** In-Wall Boxes

All dimensions = inch (mm)

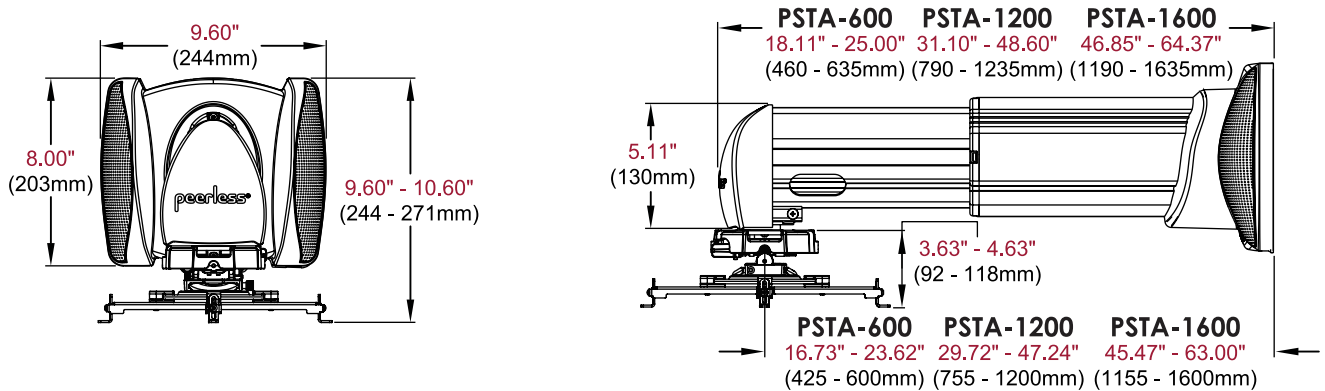

**Architect Specifications**

The Short Throw Projector Mount shall be a Peerless-AV model PSTA-600, PSTA-1200 and PSTA-1600 and shall be located where indicated on the plans. Assembly and installation shall be done according to instructions provided by the manufacturer.

Visit [peerless-av.com](http://peerless-av.com) to see the complete line of AV solutions from Peerless-AV, including outdoor displays, wireless, kiosks, digital audio, display mounts, projector mounts, carts/stands, and a full assortment of accessories.

**Peerless-AV**  
2300 White Oak Circle  
Aurora, IL 60502 USA  
**(800) 865-2112**  
**(630) 375-5100**  
**Fax: (800) 359-6500**

**Peerless-AV Europe**  
Unit 3 Watford Interchange  
Colonial Way, Watford  
Herts, WD24 4WP  
United Kingdom  
**+44 (0) 1923 200100**  
**Fax: +44 (0) 1923 200101**

**Peerless-AV de México**  
Ave de las Industrias 413  
Parque Industrial Escobedo  
Escobedo, N.L.,  
Mexico 66050  
**+52 (81) 8384-8300**  
**Fax: +52 (81) 8384-8360**

