



CHA215

Compression horn loudspeaker 15W 100V

Highlights:

- IP56 Ingress protection
- Multi-tapping 100V line transformer
- Weatherproof ABS sealed construction
- Stainless steel U bracket

The CHA215 is a powerful compression horn loudspeaker with an RMS power of 15 Watt. It is fitted with a line transformer with adjustable power taps, and can be used in 70V or 100V PA installations at 15 Watt, 7.5 Watt, 3.75 Watt or 1.9 Watt. The CHA series are compression horn loudspeakers especially designed for paging and background music applications offering durability and optimal speech and music reproduction. They are fitted with a line transformer with adjustable power taps, to be used in 70V/100V public address applications. The speakers are made from tough ABS, finished in a light grey color and with sturdy adjustable mounting bracket. The Ingress Protection rating of IP56 makes them suitable for outdoor use.

Applications:

- Public facilities
- Corporate spaces
- Sport facilities



Certification:



Voltage:

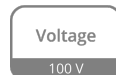

System specifications:

Max. Power		25 W
RMS Power		15 W
Line Transformer Tappings	1	15 W / 667 Ω
	2	7.5 W / 1334 Ω
	3	3.75 W / 2667 Ω
	4	1.9 W / 5334 Ω
Impedance		20 Ω
Sound Pressure (Max. W/1m)		107 dB
Frequency	Response (\pm 3 dB)	400 Hz - 9 kHz

Product Features:

Dimensions		208 x 271.5 mm (\emptyset x D)
Weight		1.950 kg
Operating temperature		-20 $^{\circ}$ C ~ 60 $^{\circ}$ C
Construction		ABS
Mounting		Inox bracket
		Inox screws
Colours		Light grey (RAL7035)
Accessories	Included	Mounting bracket

Shipping & Ordering:

Packaging	Cardboard box
Shipping weight & volume	2.750 kg - 0.025 Cbm

Architects' and Engineers' Specifications:

The loudspeaker must be a compression horn type, consisting of an 1.5" diaphragm which is built in a high quality ABS enclosure, resulting in an impact resistant and weatherproof loudspeaker. Mounting of the speaker shall be possible using a stainless steel mounting bracket allowing secure mounting and tilting for perfect directional placement.

It must have an RMS power handling of 15 Watt with a maximum power handling of 30 Watt and the frequency response (\pm 3 dB) must range from 400 Hz to 9 kHz. The sensitivity must be 107 dB when measuring with an input signal of 1 Watt at a distance of 1 meter, while the maximum continuous sound pressure level must reach 119 dB.

The loudspeaker must be fitted with a line transformer for use in 100 Volt constant voltage audio systems with multiple tappings for 15 Watt, 7.5 Watt, 3.75 Watt and 1.9 Watt which are selectable through a recessed adjuster screw located at the rear of the speaker. The enclosure shall comply to IEC60529 IP56 ratings for dust & splash resistance and feature a fixed cable to ensure an optimal connection.

The loudspeakers' enclosure must be finished in RAL7035 color, have a diameter of 208 mm with a depth of 271.5 mm and the weight shall not exceed 1.95 Kg.

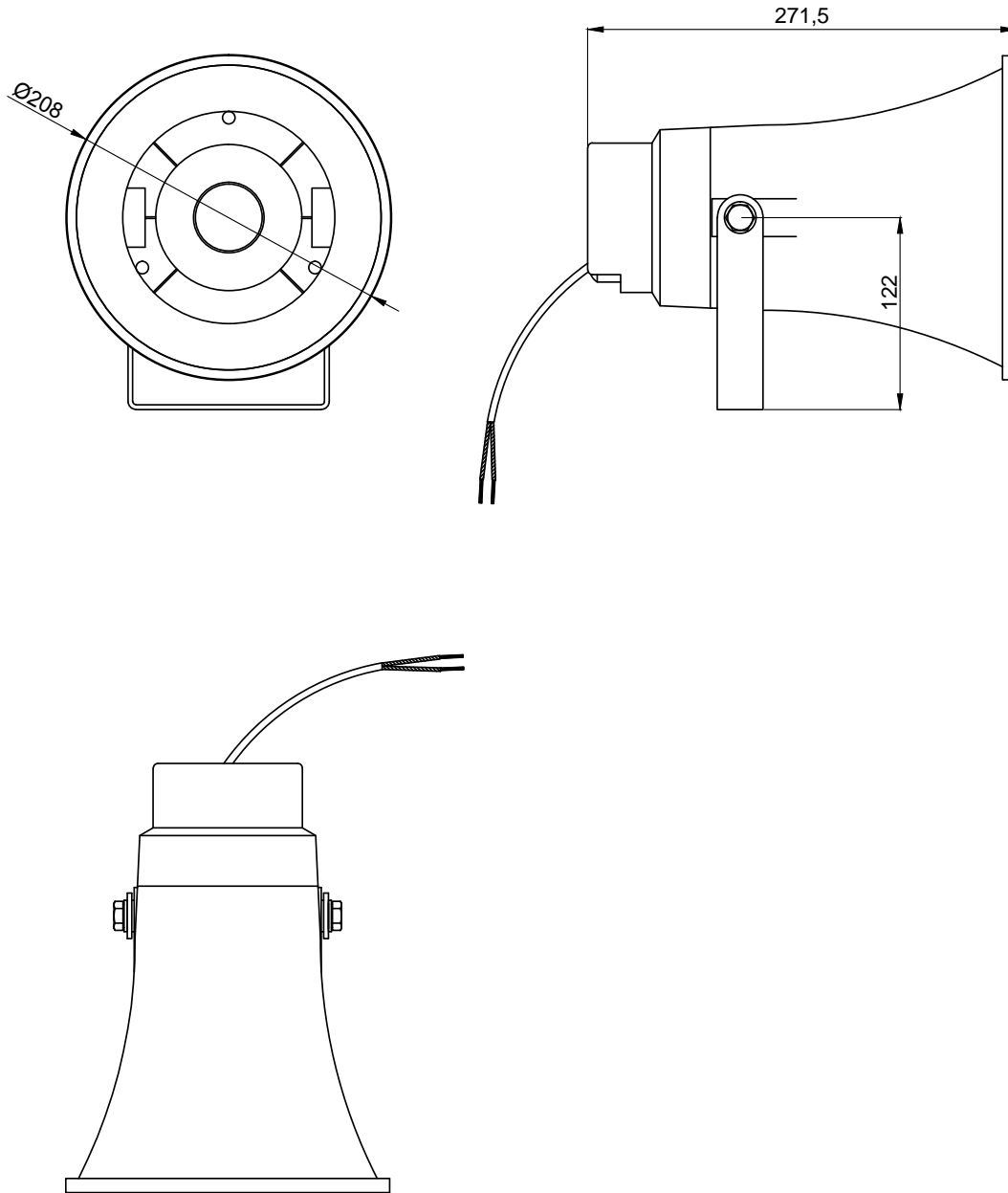

CHA215

Product description:
COMPRESSION HORN LOUDSPEAKER
15W/100V

Weight:

1,95 kg

Outer dimensions:
(w x h x d)

Ø 208 x 271,5

Unit height:

N/A