

SFX650(P)



Display size
37"-75"



Max load
120lb (54kg)

SMARTMOUNT XT

Universal Flat Wall Mount

FOR 37" TO 75" DISPLAYS

Limitless placement opportunities are delivered with speed and ease with both horizontal and vertical adjustment capability. Its slim, open wall plate architecture delivers flat panel display placement flexibility and cable management. This slim mount is the ultimate solution for secure, low-profile applications.

SFX650 delivers limitless placement opportunities with speed and ease, including horizontal and vertical adjustment for post-installation leveling.



Additional Features

- ✓ Open wall plate design allows for total wall access, increasing electrical and cable management options
- ✓ Up to 25" (635mm) of horizontal display adjustment for centering display on wall
- ✓ Up to 1" (25mm) of vertical adjustment on each universal display adaptor bracket for post-installation leveling and height adjustment fine-tuning
- ✓ Secure installation with theft resistant security screws (on security units)
- ✓ Easy-Glide™ design ensures that the display is securely attached to the wall plate
- ✓ Universal display adaptor brackets easily hook onto wall plate for fast installation
- ✓ Low-profile design holds display 1.21" (31mm) from the wall
- ✓ Fits displays with mounting hole patterns from 75 x 75mm (2.95"W x 2.95"H) to 744 x 405mm (29.29"W x 15.95"H)

POST-INSTALLATION ADJUSTMENT

±0.5" of vertical adjustment for post-installation leveling and height adjustment fine-tuning

VIEWING FLEXIBILITY

Up to 25" of horizontal adjustment for centering display on wall

EASY INSTALLATION

Universal display adaptor brackets easily hook onto wall plate for fast installation

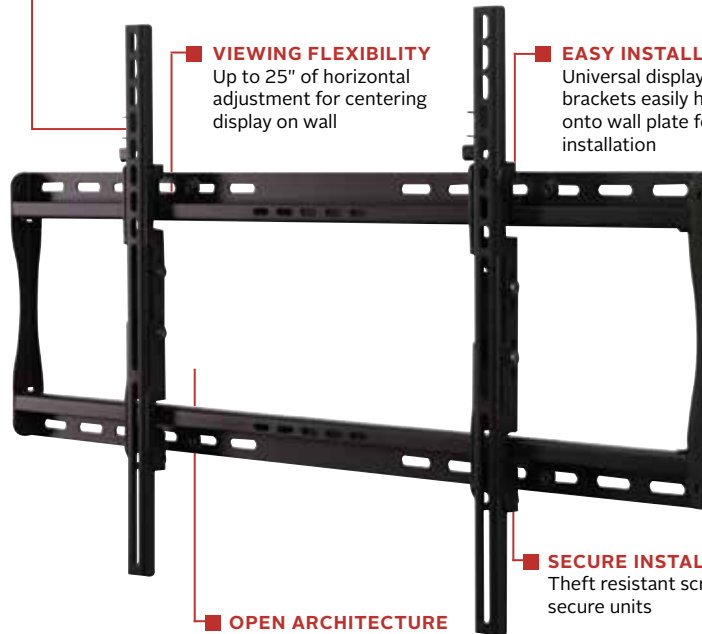

OPEN ARCHITECTURE

Open wall plate architecture for flexible cable management and wall placement

SECURE INSTALLATION

Theft resistant screws on secure units

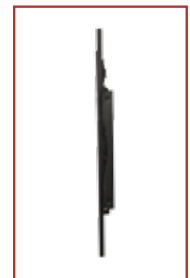

Low-profile design holds display 1.21" (31mm) from the wall



Patented. Design Patent No. D659,698. Utility Patent No. 8,348,212; 8,517,322.



INTEGRATED
PARTNER
PROGRAM

Contact your Peerless-AV sales representative for more information

info@peerless-av.com
peerless-av.com

peerless-AV®

SFX650	SmartMountXT™ Universal Flat Wall Mount for 37" to 75" Displays - security models
SFX650P	SmartMountXT™ Universal Flat Wall Mount for 37" to 75" Displays - standard models

Product Specifications

	DIMENSIONS (W x H x D)	PRODUCT WEIGHT	LOAD CAPACITY	FINISH	AVAILABLE COLORS
SFX650(P)	30.87" x 16.89" x 1.21" (784 x 429 x 31mm)	5.72lb (2.59kg)	120lb (54kg)	Powder coat	Black

Package Specifications

	PACKAGE SIZE (W x H x D)	PACKAGE SHIP WEIGHT	PACKAGE UPC CODE	PACKAGE CONTENTS	UNITS IN PACKAGE
SFX650(P)	10.125" x 3.5" x 32.5" (257 x 89 x 826mm)	8.3lb (3.76kg)	SFX650: 735029278894 SFX650P: 735029279358	Universal Flat Wall Mount, attachment hardware, installation instructions	1

Accessories

- ACCXT302:** SmartMountXT™ Video Conferencing Shelf accessory
- ACCXT400:** In-Wall Cable and Power Management Accessory with AC Surge Suppressor

All dimensions = inch (mm)

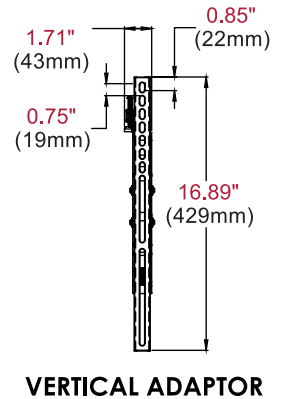
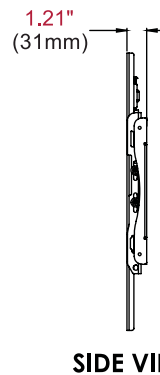
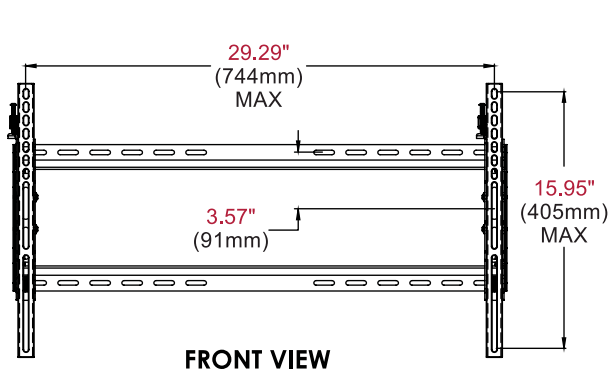
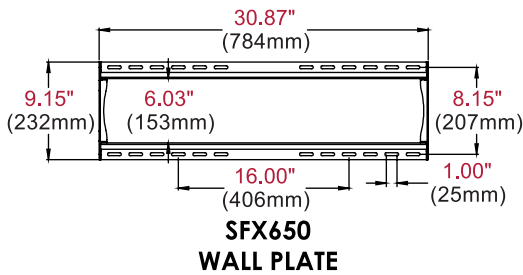

Architect Specifications

The SmartmountXT™ Universal Flat Wall Mount shall be a Peerless-AV® model SFX650 or SFX650P and shall be located where indicated on the plans. Assembly and installation shall be done according to instructions provided by the manufacturer.

Visit peerless-av.com to see the complete line of AV solutions from Peerless-AV, including outdoor displays, wireless, kiosks, digital audio, display mounts, projector mounts, carts/stands, and a full assortment of accessories.

Peerless-AV
2300 White Oak Circle
Aurora, IL 60502 USA
(800) 865-2112
(630) 375-5100
Fax: (800) 359-6500

Peerless-AV Europe
Unit 3 Watford Interchange
Colonial Way, Watford
Herts, WD24 4WP
United Kingdom
+44 (0) 1923 200100
Fax: +44 (0) 1923 200101

Peerless-AV de México
Ave de las Industrias 413
Parque Industrial Escobedo
Escobedo, N.L.,
Mexico 66050
+52 (81) 8384-8300
Fax: +52 (81) 8384-8360

