

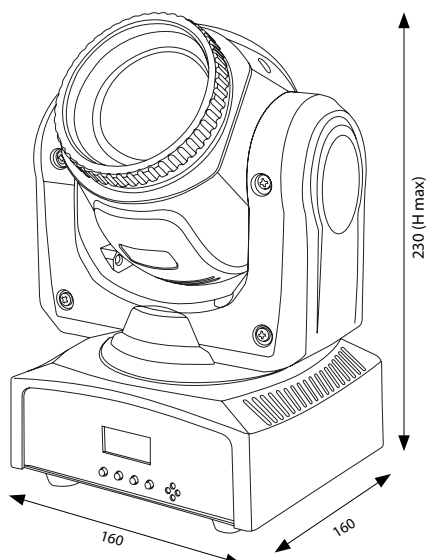

NEW



**SG SMTBEAM - PRODUCT CODE**

**LIGHT SOURCE**

- 1x40W White led high brightness
- LED lifespan: >50.000h

**OPTIC SYSTEM**

- Beam angle: 4°
- Manual focus

**COLOR SYSTEM**

- Color wheel: 11 colors + white

**EFFECTS**

- Gobo wheel: 11 fixed gobos
- Gobo scroll from slow to fast
- Color rainbow effect with adjustable speed
- Linear dimmer 0-100%
- Electronic high speed strobe from 1 to 20 flashes/s, with adjustable speed.
- Pan/Tilt macros selectable from DMX

**CONTROL AND PROGRAMMING**

- 2 different DMX channels configurations: 9/11 channels
- Protocol USITT DMX 512
- Master/Slave mode
- Sound mode with adjustable sensitivity of microphone
- Reset via DMX

**STRUCTURE AND CABINET**

- Black metal Housing, and plastic materials with high resistance
- Red LED display
- Pan 540° / Tilt 210°
- Mounting points: 1 omega holder + safety ring
- 3-poles XLR in/out connection
- IP Rating: IP 20
- Forced air fan cooling system

**POWER SUPPLY**

- Input Voltage: AC~100-240V 50/60Hz
- Switching power supply unit
- Max Power: 50W @ 230VAC
- Power connection with VDE sockets
- Power supply cable 1,5 mt included

**WEIGHT AND DIMENSIONS**

- Net weight: 2,4 kg
- Dimensions: 160x160x230mm

