



USER MANUAL

SW218XP

passive subwoofer

KEY FEATURES

- Very High Output
- Compact size for a very good output-to-weight ratio
- High-strength, water repellent, glass fiber reinforced cones
- Manifolded Transmission Line configuration for very fast transient response
- Tetracoil dual voice coil for extended linear response and increased power handling

INTRODUCTION

The SW218XP subwoofer is designed to deliver high quality low frequency reproduction where very high output is a key requirement, together with well defined deep bass response and fast transient response. Its compact size and light weight make it suitable for several different uses, ranging from touring applications to fixed installations and high-level dance clubs.

The SW218XP is a very high quality powered subwoofer system featuring some of the most advanced technologies for low frequency reproduction. Its unique and innovative design is based on a configuration that can be defined as Manifolded Transmission Line.

It uses manifolding of the front side of the cones to maximize the mutual coupling between the two drivers, while loading the back of the cone with a large-size transmission line that has the function to create a transmission path from the back of the transducers to the front. This innovative configuration does not use any large resonant cavity to load the speaker in order to get the lower octave and this reduces significantly pressure decay time inside the enclosure, with large advantages in terms of definition both at the lowest end and the upper bass. At the same time, it doesn't use very long transmission line paths as well. Its working principle is an hybrid combination between a short transmission line and an overdamped reflex load. Moreover, the maximization of the mutual coupling between the drivers increase the fastness of the transient response while maximizing the overall energy efficiency as well.

The SW218P subwoofer system is equipped with two high power 18" (460mm) transducers capable of long excursion (up to 30mm peak-to-peak), and featuring a large displacement suspension system. These transducers use Tetracoil technology, where two different, axially separated magnetic gaps and two inside-outside 100mm (4") diameter voice coils are wound on the same former and suspended evenly in the two magnetic gaps. This creates an equivalent voice coil diameter greater than 6", resulting in a larger heat dissipation area for and increased power handling. Additional key advantages of the Tetracoil technology are also minimized distortion and a very symmetric and flat inductance curve. Cones are made of very high-stiffness fiberglass reinforced paper, featuring also invisible water repellent treatment.

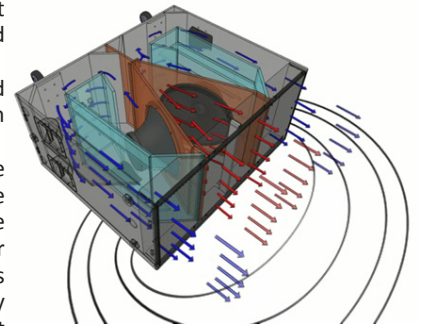

TECHNICAL SPECIFICATION

Acoustical		Connectors	
System type	Manifolded Transmission Line	Connector Type	Neutrik® Speakon® NL4 x 2
Transducer	Two 18" (460 mm), 4" (100 mm) VC, Water repellent cone and epoxy coated plates, 100mm (4in) Tetracoil dual voice coil, equivalent to a single coil diameter larger than 152mm (>6in) suspension, ultra linear suspension behavior	Input Wiring	LF1 = Pin 1+/-; LF2 = Pin 2+/-
Frequency response (±3 dB)	30 Hz – 92 Hz (Processed)	Mechanical	
Frequency response (±10 dB)	27 Hz – 300 Hz (Unprocessed)	Width	1215 mm (47.87")
Sensitivity (1.41V @ 1m, 2Pi)	101 dB (averaged from 40 to 100 Hz)	Height	590 mm (23.24")
Maximum Peak SPL @ 1m	143 dB	Depth	950 mm (37.43")
Electrical		Depth with Wheels / Dolly	1078 mm (42.44") / 1110 mm (43.70")
Nominal Impedance	8 Ω + 8 Ω	Construction	15 mm, reinforced Phenolic Birch
Minimum Impedance	5.7 Ω + 5.7 Ω @ 36 Hz	Paint	High resistance, water based paint
Power Handling Continuous*	1800 W + 1800 W	Transport	10 handles
Power Handling Program	3600 W + 3600 W	Net Weight	114 Kg (251.3 lbs.)
Power Handling Peak	7000 W + 7000 W	Wheels or Transport Dolly	4 heavy-load 100 mm Ø (optional)
Power Compression	@ -10 dB Power (180 W + 180 W) = 0.6 dB @ -3 dB Power (900 W + 900 W) = 2.0 dB @ 0 dB Power (1800 W + 1800 W) = 3.4 dB		

* AES Pink Noise Power





MECHANICAL DRAWING

with optional wheels

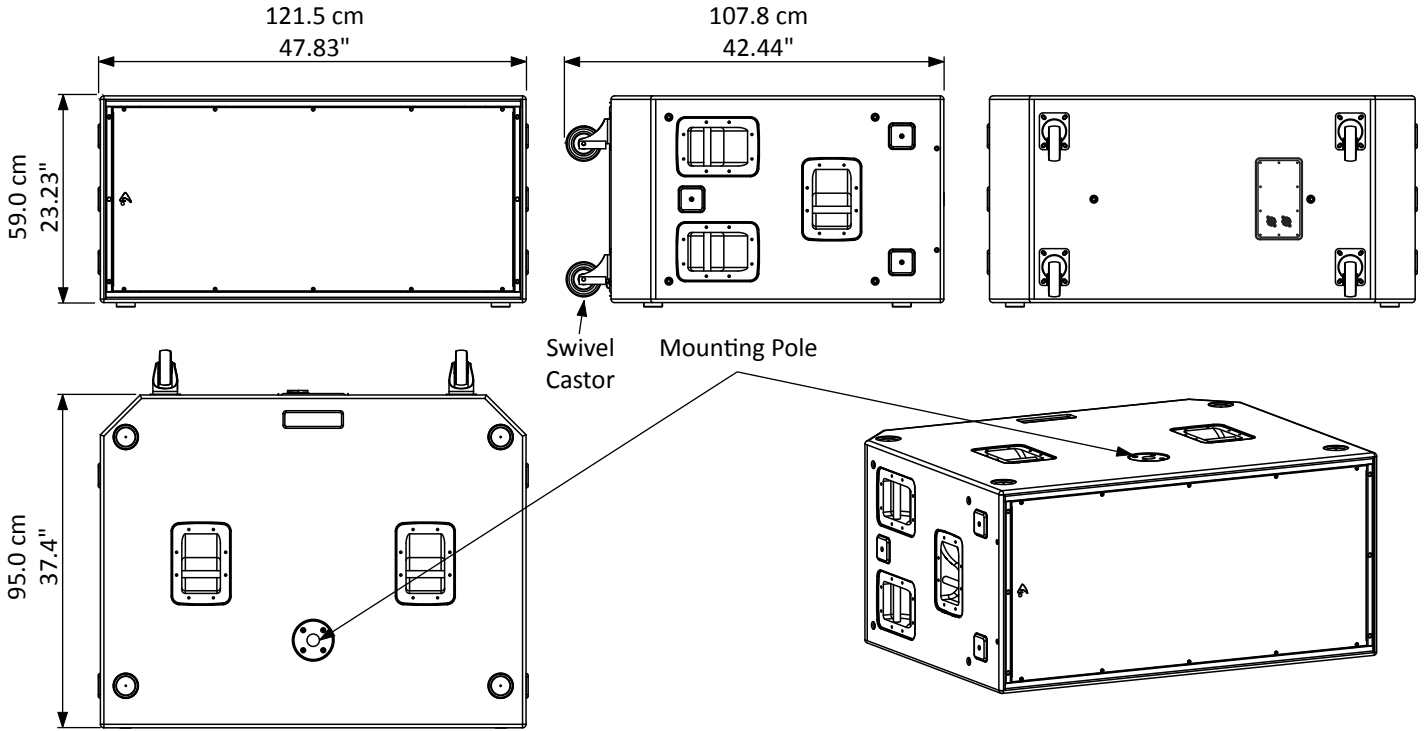

with optional transport dolly

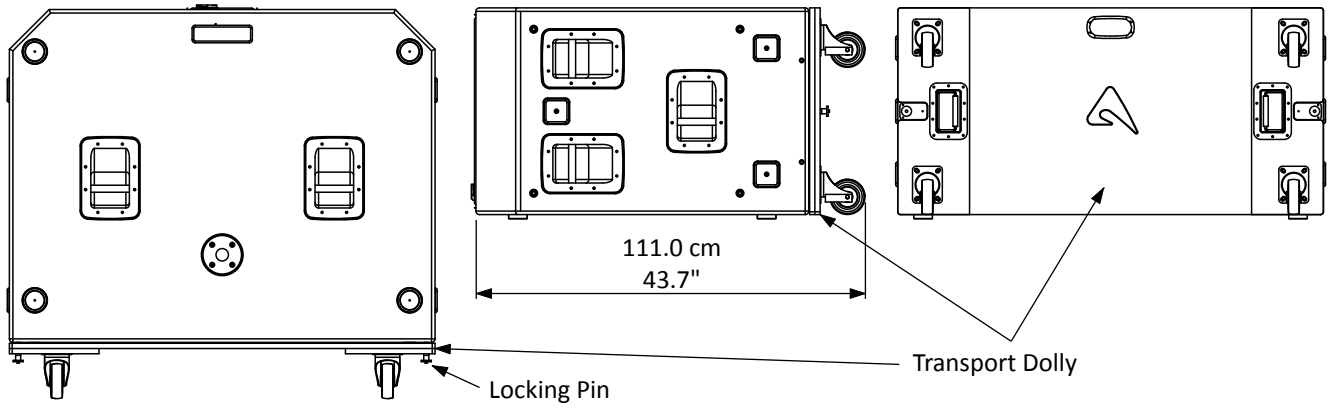



OPTIONAL ACCESSORIES

- (available soon) Transport Dolly
- AC103GS 100 mm Swivel castor without brake
- NL4FX Neutrik Speakon® PLUG
- PC260 2 in 6 out digital loudspeaker processor
- USB2CAN PRONET network converter

see <http://www.axiomproaudio.com/> for detailed description and other available accessories.

SPARE PARTS

- AC103GS 100 mm Swivel castor without brake
- AC115DN Black steel handle
- 98AXM218TLW8 18" woofer - 4" Tetracoil® dual voice coil - 8 ohm
- NL4MP Neutrik Speakon® panel socket

REAR PANEL

INPUT - Power input for the external amplifier. The SW218XP does not include a passive crossover for filtering the signal. The connections are the following:

INPUT - LINK	
NL4 pin number	internal connection
1+	LF1+
1-	LF1-
2+	LF2+
2-	LF2-

⚠ WARNING
To avoid damage, during use
both loudspeakers must be connected

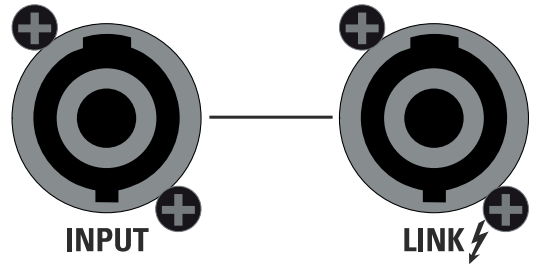

LINK - Power output in parallel with the INPUT socket for connecting the unit to another speaker. The number of SW218P cabinets that can be connected in parallel depends on the amplifier load capacity.





LIMITED WARRANTY

Proel warrants all materials, workmanship and proper operation of this product for a period of two years from the original date of purchase. If any defects are found in the materials or workmanship or if the product fails to function properly during the applicable warranty period, the owner should inform about these defects the dealer or the distributor, providing receipt or invoice of date of purchase and defect detailed description. This warranty does not extend to damage resulting from improper installation, misuse, neglect or abuse. Proel S.p.A. will verify damage on returned units, and when the unit has been properly used and warranty is still valid, then the unit will be replaced or repaired. Proel S.p.A. is not responsible for any "direct damage" or "indirect damage" caused by product defectiveness.

- This unit package has been submitted to ISTA 1A integrity tests. We suggest you control the unit conditions immediately after unpacking it.
- If any damage is found, immediately advise the dealer. Keep all unit packaging parts to allow inspection.
- Proel is not responsible for any damage that occurs during shipment.
- Products are sold "delivered ex warehouse" and shipment is at charge and risk of the buyer.
- Possible damages to unit should be immediately notified to forwarder. Each complaint for package tampered with should be done within eight days from product receipt.

SAFETY INSTRUCTIONS

- To reduce the risk, close supervision is necessary when the product is used near children.
- Protect the apparatus from atmospheric agents and keep it away from water, rain and high humidity places.
- This product should be site away from heat sources such as radiators, lamps and any other device that generate heat.
- This product should be located so that its location or position does not interfere with its proper ventilation and heating dissipation.
- Care should be taken so that objects and liquids do not go inside the product.
- The product should be connected to a power supply mains line only of the type described on the operating instructions or as marked on the product. Connect the apparatus to a power supply using only power cord included making always sure it is in good conditions.
- **WARNING:** The mains plug is used as disconnect device, the disconnect device shall remain readily operable.
- Do not cancel the safety feature assured by means of a polarized line plug (one blade wider than the other) or with a earth connection.
- Make sure that power supply mains line has a proper earth connection.
- Power supply cord should be unplugged from the outlet during strong thunderstorm or when left unused for a long period of time.

CE CONFORMITY

Proel products comply with directive 2004/108/EC (EMC), as stated in EN 55103-1 and EN 55103-2 standards and with directive 2006/95/CE (LVD), as stated in EN 60065 standard.

PROEL S.p.A. (World Headquarter) - Via alla Ruenia 37/43 - 64027 Sant'Omero (Te) - ITALY
Tel: +39 0861 81241 Fax: +39 0861 887862 www.axiomproaudio.com

