

**Kramer Electronics, Ltd.**



# **USER MANUAL**

**Model:**

**TBUS-2**

## Contents

<b>1</b>	<b>Introduction</b>	<b>1</b>
<b>2</b>	<b>Getting Started</b>	<b>1</b>
2.1	Quick Start	1
<b>3</b>	<b>Overview</b>	<b>3</b>
<b>4</b>	<b>Your TBUS-2 Connection Bus</b>	<b>5</b>
<b>5</b>	<b>Connecting the TBUS-2 Connection Bus</b>	<b>7</b>
5.1	Cutting an Opening	7
5.2	Inserting the TBUS-2 through the Cut-Out Opening	8
5.3	Installing the Required Kramer Inserts	8
<b>6</b>	<b>Technical Specifications</b>	<b>9</b>

## Figures

Figure 1:	TBUS-2 Table Connection Bus	3
Figure 2:	TBUS-2 Table Connection Bus (Side View)	5
Figure 3:	TBUS-2 Connecting Surface	6
Figure 4:	TBUS-2 Power Sockets	6
Figure 5:	Cutout Dimensions	7

## Tables

Table 1:	TBUS-2 Table Connection Bus Features	5
Table 2:	TBUS-2 Connecting Surface Features	6
Table 3:	Technical Specifications of the TBUS-2	9

## 1 Introduction

Welcome to Kramer Electronics (since 1981): a world of unique, creative and affordable solutions to the infinite range of problems that confront the video, audio and presentation professional on a daily basis. In recent years, we have redesigned and upgraded most of our line, making the best even better! Our 500-plus different models now appear in 8 Groups<sup>1</sup>, which are clearly defined by function.

Congratulations on purchasing your Kramer **TBUS-2** table bus, which is ideal for boardrooms, conference and training rooms!

The package includes the following items:

- **TBUS-2** *Table Bus System*
- Power cord
- This user manual<sup>2</sup>

## 2 Getting Started

We recommend that you:

- Unpack the equipment carefully and save the original box and packaging materials for possible future shipment
- Review the contents of this user manual
- Use Kramer high performance high resolution cables<sup>3</sup>

### 2.1 Quick Start

This Quick start chart summarizes the basic steps when connecting a **TBUS-2**:

---

1 GROUP 1: Distribution Amplifiers; GROUP 2: Video and Audio Switchers, Matrix Switchers and Controllers; GROUP 3: Video, Audio, VGA/XGA Processors; GROUP 4: Interfaces and Sync Processors; GROUP 5: Twisted Pair Interfaces; GROUP 6: Accessories and Rack Adapters; GROUP 7: Scan Converters and Scalers; and GROUP 8: Cables and Connectors

2 Download up-to-date Kramer user manuals from our Web site: <http://www.kramerelectronics.com>

3 The complete list of Kramer cables is on our Web site at <http://www.kramerelectronics.com>

**Cut out an opening in the table - see section 5.1**

Cut out an opening in your table according to the cutout template

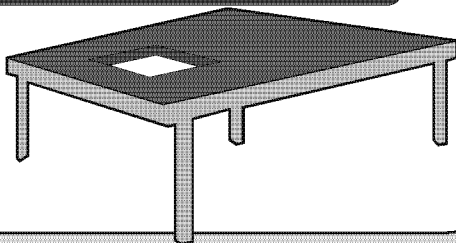

**Insert the unit - see section 5.2**

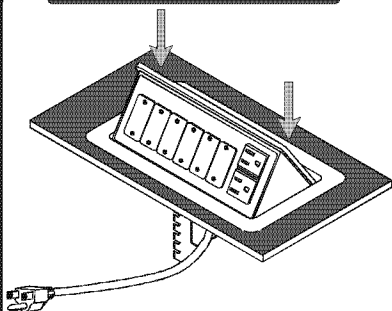

- Set the support brackets at the desired height
- Make sure that the outer rim is situated parallel to the edge of the table
- Secure the TBUS-2 to the table from the underneath
- Secure the cables
- Connect the appropriate cables underneath

**Connect the modular wall plate items - see section 5.3**

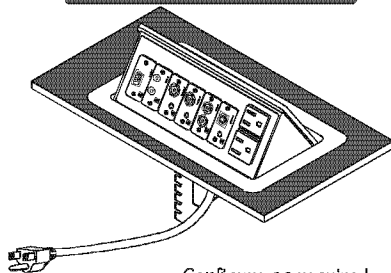

Configure as required

### 3 Overview

The **TBUS-2** is a furniture-mounted connection bus that is easily installed into a table or podium top. The **TBUS-2** lets you connect any equipment to the room's presentation system installations via cable access or passive interfaces. When not in use, you can lower the **TBUS-2** flush into the table. The example in Figure 1 shows the **TBUS-2** in a table or podium top with a power socket suitable for the US.

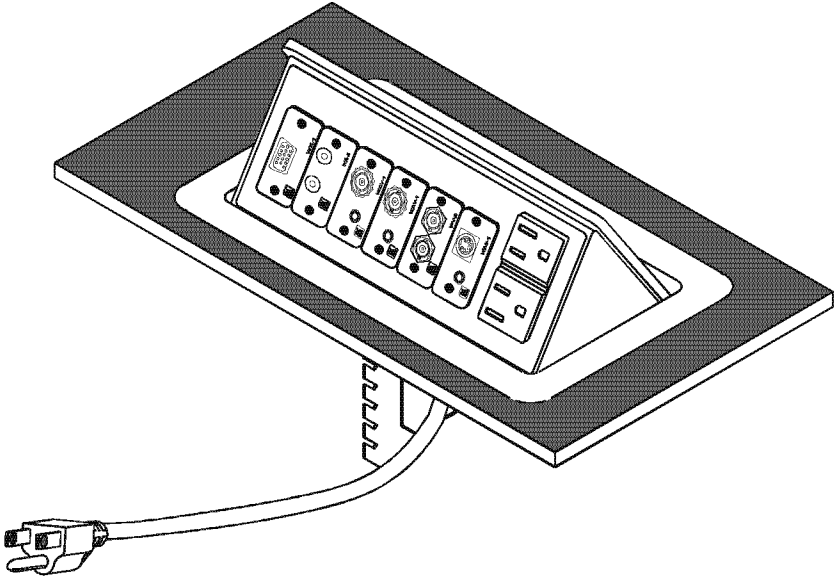

*Figure 1: TBUS-2 Table Connection Bus*

In addition, the **TBUS-2** is:

- Easily opened and closed by pressing down gently on the lid<sup>1</sup>
- Modular in design, letting you tailor it according to your needs<sup>2</sup>
- Available with different power outlet connections<sup>3</sup>

---

1 Due to its tilting angular construction, pneumatic lift and mechanical latching mechanism, it can be raised (when in use) or lowered (when not in use)

2 The complete list of Kramer inserts, for designing the Connecting Surface, can be found on our Web site at <http://www.kramerelectronics.com>

3 Suitable for Australia, Belgium and France, Germany and the EU, Italy, South Africa, the UK and the US

To achieve the best performance:

- Connect only good quality connection cables, thus avoiding interference, deterioration in signal quality due to poor matching, and elevated noise levels (often associated with low quality cables)
- Avoid interference from neighboring electrical appliances that may adversely influence signal quality and position your Kramer **TBUS-2** away from moisture, excessive sunlight and dust



Never place fingers inside the opening on each side of the unit. This could cause serious injury because of the sharp edges inside the **TBUS-2**.

Do not place heavy objects on top of the **TBUS-2**

Do not use excessive force to push down the top of the unit.

## 4 Your TBUS-2 Connection Bus

Figure 2 and Table 1 define the **TBUS-2** unit:

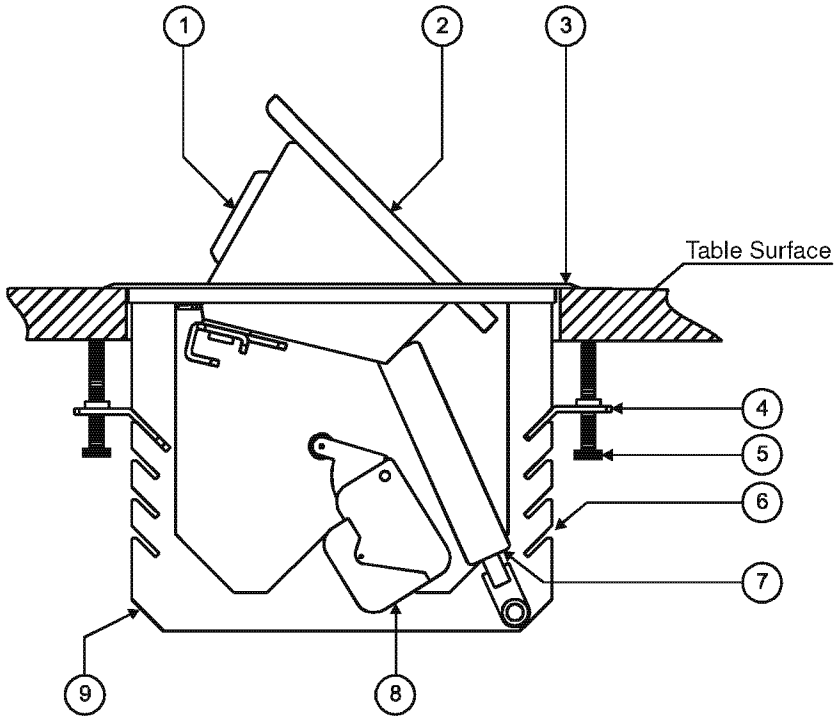

Figure 2: TBUS-2 Table Connection Bus (Side View)

Table 1: TBUS-2 Table Connection Bus Features

#	Feature	Function
1	Connecting Surface	See Figure 3 and Table 2
2	Black Textured Lid	Covers the connecting surface, leaving the table surface neat and tidy
3	Outer Rim	Fits over the table surface
4	Support Bracket	Supports the table securing screw (two sets)
5	Table Securing Screw	Tighten to secure the unit to the table surface (two sets)
6	Support Bracket Grooves	Hold the support bracket at the required height (four on each side)
7	Pneumatic Lift	Enables smooth lifting and closing of the lid
8	Mechanical Latching Mechanism	Enables closing and opening the lid by slightly pressing it
9	Enclosure	Located underneath the table surface

Figure 3 and Table 2 define the Connecting Surface:

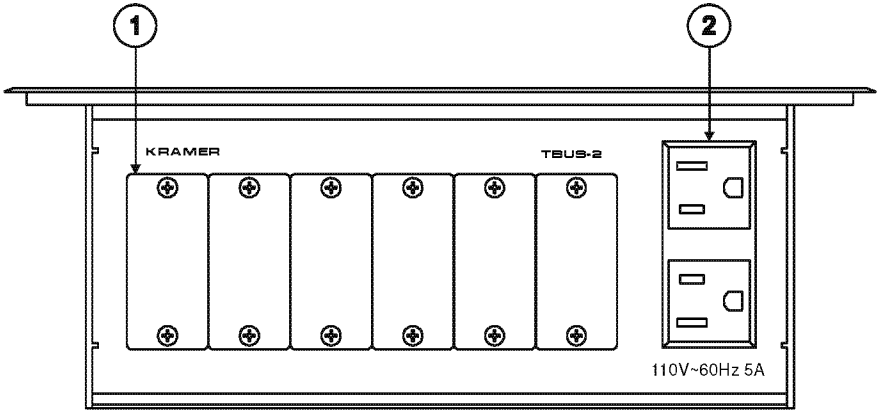

Figure 3: TBUS-2 Connecting Surface

Table 2: TBUS-2 Connecting Surface Features

#	Feature	Function
1	Blank Plates	Six blank covers that can be replaced with Kramer inserts as required (see section 5.3)
2	Power Sockets <sup>1</sup>	Suitable for US power requirements

In addition to the US power socket, the **TBUS-2** is also available with other types of power sockets, as illustrated in Figure 4:

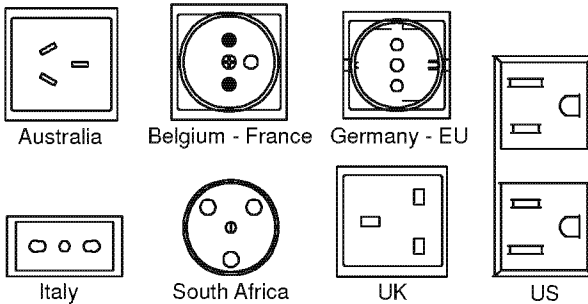

Figure 4: TBUS-2 Power Sockets

<sup>1</sup> Also available with other types of power sockets (see Figure 4)



## 5 Connecting the TBUS-2 Connection Bus

This section describes how to connect the **TBUS-2**:

- Cut an opening in the table (see section 5.1)
- Insert the **TBUS-2** through the cut-out opening (see section 5.2)
- Install the required Kramer inserts (see section 5.3)

### 5.1 Cutting an Opening

Figure 5 illustrates the cutout template (not to scale) defining the surface you have to cut out to install your **TBUS-2**.

A template can be downloaded from our Web site<sup>1</sup>

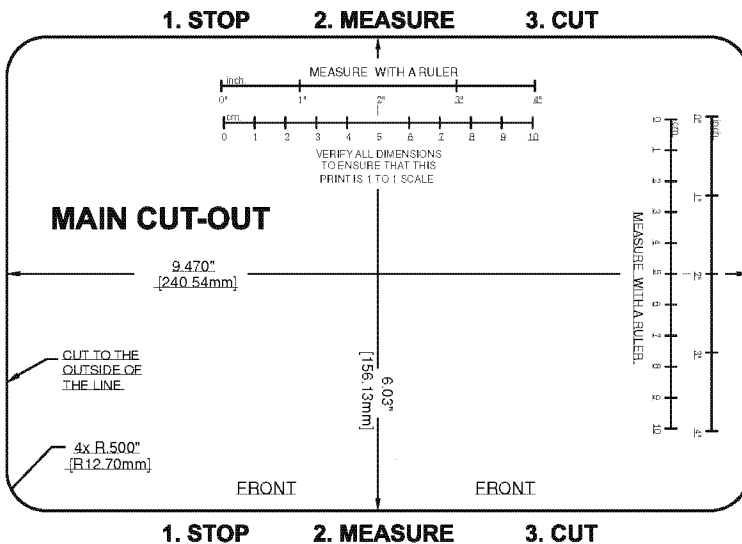

Figure 5: Cutout Dimensions

The thickness of the table should be 3" or less.

Before cutting the opening, confirm the dimensions and make sure that the specifications have not changed.

Cut out the wooden surface in which you want to insert the **TBUS-2**. Take care not to cause damage to the table.

**Kramer Electronics is not responsible for any damage caused to the table**

<sup>1</sup> At <http://www.kramerelectronics.com>

## 5.2 Inserting the TBUS-2 through the Cut-Out Opening

To install the **TBUS-2**, do the following:

1. Carefully insert the unit into the prepared opening.
2. Take the support brackets under the table and place them into the support bracket grooves at the desired height (on both the front and rear sides of the unit).
3. Make sure that the upper outer rim is situated parallel to the edge of the table.
4. Insert the table securing screw through the holes in the support brackets and tighten them until they reach the table surface (from underneath).
5. Secure the cables.  
Do not keep the cord too tight or too loose.
6. Connect the appropriate cables to the mounted Kramer inserts from underneath.

Once you have connected the unit to mains power and connected the proper cables, you may use the unit.

## 5.3 Installing the Required Kramer Inserts

You can install the Kramer inserts before or after installing the **TBUS-2**.

By default, the mounting surface includes a power socket (different power sockets are available, see Figure 4), and six blank plates for optional video, audio, telephone and network connectors.

Any of the Kramer inserts mounted to the connecting surface can be rearranged or removed and replaced with Kramer inserts<sup>1</sup> or connector modules for interfacing A/V type signals.

To mount a Kramer insert or connector module, do the following:

1. Unscrew the two screws that fasten the blank plate to the connecting surface and remove the blank plate.
2. Place the required Kramer insert over the opening, insert the two screws to fix the Kramer insert in place, and tighten them.

---

<sup>1</sup> The complete list of Kramer inserts and module connectors is on our Web site at <http://www.kramerelectronics.com>

## 6 Technical Specifications

Table 3 includes the technical specifications:

*Table 3: Technical Specifications<sup>1</sup> of the TBUS-2*

POWER SOURCE (AC power limits):	Dual US	110V AC, 60 Hz, 2.5A per connector
	Germany and the EU	220-240V AC, 50/60 Hz, 5A per connector
	Belgium and France	220-240V AC, 50/60 Hz, 5A per connector
	The UK	220-240V AC, 50/60 Hz, 5A per connector
	South Africa	220-240V AC, 50/60 Hz, 5A per connector
	Italy	220-240V AC, 50/60 Hz, 5A per connector
	Australia	220-240V AC, 50/60 Hz, 5A per connector
DIMENSIONS:	Including the outer rim: 25.3cm x 16.6cm x 18.4cm (9.97" x 6.53" x 7.25") W, D, H Without the outer rim: 24cm x 15.6cm x 18.4cm (9.47" x 6.03" x 7.25") W, D, H	
WEIGHT:	1.15kg. (2.53lbs.) approx.	
ACCESSORIES:	Power cord	
OPTIONS:	Kramer inserts and interfaces <sup>2</sup>	

<sup>1</sup> Specifications are subject to change without notice

<sup>2</sup> The complete list of Kramer inserts and module connectors is on our Web site at <http://www.kramerelectronics.com>

---

## LIMITED WARRANTY

Kramer Electronics (hereafter *Kramer*) warrants this product free from defects in material and workmanship under the following terms.

### HOW LONG IS THE WARRANTY

Labor and parts are warranted for seven years from the date of the first customer purchase.

### WHO IS PROTECTED?

Only the first purchase customer may enforce this warranty.

### WHAT IS COVERED AND WHAT IS NOT COVERED

Except as below, this warranty covers all defects in material or workmanship in this product. The following are not covered by the warranty:

1. Any product which is not distributed by Kramer, or which is not purchased from an authorized Kramer dealer. If you are uncertain as to whether a dealer is authorized, please contact Kramer at one of the agents listed in the Web site [www.kramerelectronics.com](http://www.kramerelectronics.com).
2. Any product, on which the serial number has been defaced, modified or removed.
3. Damage, deterioration or malfunction resulting from:
  - i) Accident, misuse, abuse, neglect, fire, water, lightning or other acts of nature
  - ii) Product modification, or failure to follow instructions supplied with the product
  - iii) Repair or attempted repair by anyone not authorized by Kramer
  - iv) Any shipment of the product (claims must be presented to the carrier)
  - v) Removal or installation of the product
  - vi) Any other cause, which does not relate to a product defect
  - vii) Cartons, equipment enclosures, cables or accessories used in conjunction with the product

### WHAT WE WILL PAY FOR AND WHAT WE WILL NOT PAY FOR

We will pay labor and material expenses for covered items. We will not pay for the following:

1. Removal or installations charges.
2. Costs of initial technical adjustments (set-up), including adjustment of user controls or programming. These costs are the responsibility of the Kramer dealer from whom the product was purchased.
3. Shipping charges.

### HOW YOU CAN GET WARRANTY SERVICE

1. To obtain service on you product, you must take or ship it prepaid to any authorized Kramer service center.
2. Whenever warranty service is required, the original dated invoice (or a copy) must be presented as proof of warranty coverage, and should be included in any shipment of the product. Please also include in any mailing a contact name, company, address, and a description of the problem(s).
3. For the name of the nearest Kramer authorized service center, consult your authorized dealer.

### LIMITATION OF IMPLIED WARRANTIES

All implied warranties, including warranties of merchantability and fitness for a particular purpose, are limited in duration to the length of this warranty.

### EXCLUSION OF DAMAGES

The liability of Kramer for any effective products is limited to the repair or replacement of the product at our option. Kramer shall not be liable for:

1. Damage to other property caused by defects in this product, damages based upon inconvenience, loss of use of the product, loss of time, commercial loss; or:
2. Any other damages, whether incidental, consequential or otherwise. Some countries may not allow limitations on how long an implied warranty lasts and/or do not allow the exclusion or limitation of incidental or consequential damages, so the above limitations and exclusions may not apply to you.

This warranty gives you specific legal rights, and you may also have other rights, which vary from place to place.

**NOTE:** All products returned to Kramer for service must have prior approval. This may be obtained from your dealer.

This equipment has been tested to determine compliance with the requirements of:

- EN-50081: "Electromagnetic compatibility (EMC); generic emission standard.  
Part 1: Residential, commercial and light industry"
- EN-50082: "Electromagnetic compatibility (EMC) generic immunity standard.  
Part 1: Residential, commercial and light industry environment".
- CFR-47: FCC Rules and Regulations:  
Part 15: "Radio frequency devices  
Subpart B Unintentional radiators"

### CAUTION!

- Servicing the machines can only be done by an authorized Kramer technician. Any user who makes changes or modifications to the unit without the expressed approval of the manufacturer will void user authority to operate the equipment.
- Use the supplied DC power supply to feed power to the machine.
- Please use recommended interconnection cables to connect the machine to other components.



---

For the latest information on our products and a list of Kramer distributors, visit our Web site: [www.kramerelectronics.com](http://www.kramerelectronics.com), where updates to this user manual may be found. We welcome your questions, comments and feedback.

 <p><b>Caution</b></p>	<p><b>Safety Warning:</b> Disconnect the unit from the power supply before opening/servicing.</p>
---	---



---

**Kramer Electronics, Ltd.**  
Web site: [www.kramerelectronics.com](http://www.kramerelectronics.com)  
E-mail: [info@kramereel.com](mailto:info@kramereel.com)  
P/N: 2900-000230 REV 1