

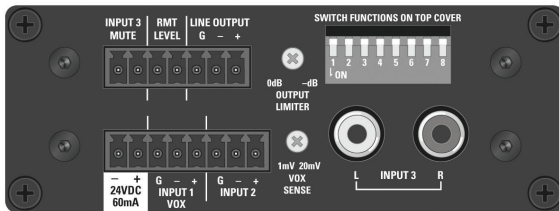

**TSD-MIX31RL**  
**3x1 Mic/Line Mixer**  
**with Priority Mute & Remote Level**



1601 Jack McKay Blvd. • Ennis, Texas 75119 U.S.A.  
Telephone: 800.876.3333 • Fax: 800.765.3435



## Description

The versatile Atlas Sound TSD-MIX31RL 3x1 mic/line mixer is ideal for applications where paging, public address, and BGM music are required. Use alone or in conjunction with amplifiers in meeting rooms, stadiums, gymnasiums, and other applications requiring versatile, multi source mix control.

The unit includes two mic/balanced line inputs via removable Phoenix style connectors and a stereo summing dual RCA input. Switchable phantom power is provided for both mic inputs to facilitate condenser microphones. The high quality, low noise internal mic preamps ensure clarity and quiet operation without unwanted coloration. A 12dB/octave high pass filter @ 125Hz also is available on each input to minimize bass rumble and low frequency feedback.

Priority paging can be accomplished via contact closure or VOX trigger on Input 1 (mutes input 3 only). Remote level control feature allows use of the Atlas Sound AAVC-10K (or equivalent) decorative wall plate control for convenient remote adjustment of either the entire mix bus or input 3 only (typical BGM input). A variable output limiter provides system protection by reducing clipping and distortion - which is especially useful when mixing multiple mics and/or line sources with varying volumes.

The TSD-MIX31RL is part of a full line of Atlas Sound Time Saving Devices. These compact (1.5" x 4" x 2.75") units are designed to solve some of the common audio system problems in the easiest and in the most efficient and cost-effective way. All models are made from high quality components and include removable individual I/O connectors for quick and precise wiring, separate ground terminals for all I/Os assuring secured connections, and removable level controls that can be replaced with tamper-proof security covers. The TSDs are highly efficient and meet Energy Star™ standards as one 24V DC power supply (available separately) can power multiple Time Saving Devices.

## Features

- Two (2) Balanced Mic/Line Inputs
- High Gain (50dB) Microphone Preamps
- Switchable 24V Phantom Power
- One (1) Unbalanced Summing Line Input
- Vox Sense and Contact Closure Priority Mute of Ch3
- Variable Output Limiter
- Remote Level Control
- 12dB/Octave Low Cut Filter @ 125Hz
- Input Signal & Peak Indicator LEDs
- High Gain Output for Driving Long Balanced Lines
- Separate Ground Connections
- Removable Phoenix Style I/O Connectors
- Security Covers
- Cable Management System
- Multiple Mounting Configurations
- Meets Energy Star™ Standards
- Compact Chassis Design

## Audio Applications

- Mixer
- Mic Preamp
- Line Preamp
- Stereo Summing Preamp
- Line Drive
- Remote Level Control
- Priority Paging

## Installation

- Churches
- Restaurants
- Sports Bars
- Schools
- Industrial Facilities
- House of Worship





### Front Panel Description

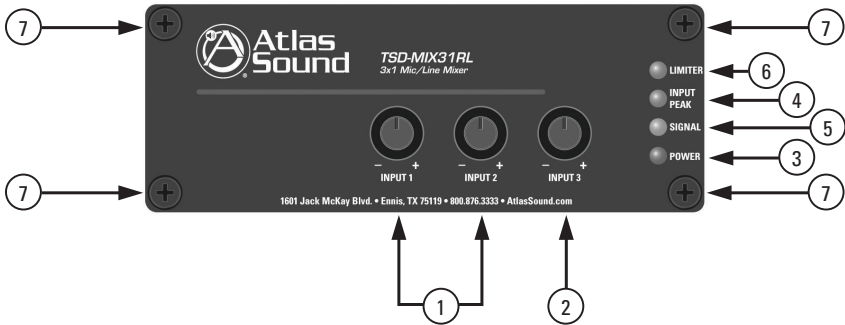

- Inputs Level Controls 1 and 2** - Independently adjust the gain of the input 1 and 2 input signals. Turn clockwise to increase the signal level and counter-clockwise to decrease it. **Note:** The Input Level Control knobs can be removed and replaced with a supplied security cover to prevent unauthorized adjustment.
- Input Level Control 3** - Adjusts the gain of the input level of the input 3 stereo RCA inputs. Turn clockwise to increase the signal level and counter-clockwise to decrease it. **Note:** The Input Level Control knobs can be removed and replaced with a supplied security cover to prevent unauthorized adjustment.
- Power LED** - Illuminates Blue when 24VDC is present.
- Input Peak LED** - Illuminates Red when the input signal reaches 3dBV below when signal clipping will occur. Occasional flashing is normal but if this indicator is continuously On, then reduce the input level using the input level control on the front panel.
- Signal LED** - Illuminates Green when the input signal strength reaches 25mV to verify a signal path. **Note:** The LED will not illuminate if the input level is turned Off.
- Limiter LED** - Adjustment of the Limiter feature should be done after the input gain(s) have been properly set. Each Input should be adjusted so the Input Peak LED flashes on signal peaks and then the Output Limiter control can be set so this LED flashes to indicate that the limiter circuit is active.
- Bracket Retainer Points** - Each TSD includes two mounting brackets for securing the TSD to a cabinet or wall. Remove screws and align the bracket with the panel hole before firmly tightening the screws.



1601 Jack McKay Blvd. • Ennis, Texas 75119 U.S.A.  
Telephone: 800.876.3333 • Fax: 800.765.3435



## Rear Panel Description

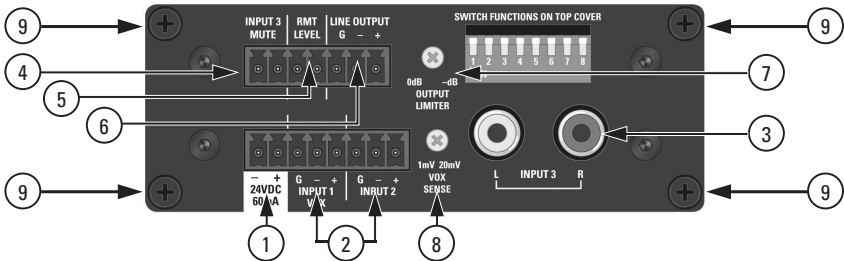

TSD Input/Output connections are removable for easy system wiring. The connector has a 3.5mm pitch between pins.

- DC Power Input** - Each TSD that requires DC power comes with a 2 position connector for an external 24VDC power supply (sold separately). Because of the low power consumption, a single external power supply may power more than one TSD. Refer to the current requirements in milliamps to match with the appropriate power supply. **Note:** It is acceptable to exceed the current of the TSDs but NOT safe to use a power supply that is below the current requirement of the device.
- Balanced Inputs 1 and 2** - Connects to balanced line or mic level sources. For gain or source input type selection, refer to the "Dip Switch Function Identification" chart. Note: Unbalanced line inputs can be inserted with proper wire configuration by connecting the (G) and (-) terminals together.
- Unbalanced Input 3** - Electronically sums unbalanced audio signals through stereo RCA connectors. Level control is on the front panel. Input 3 can be muted via contact closure or an audio signal on Input 1 for priority paging applications.
- Input 3 Remote Mute** - Connect a dry contact closure across these two terminals to mute Input 3 when the switch is closed. Dip Switch 7 must be in the On position.
- Remote Level** - For remote gain control, connect the Atlas Sound AAVC-10K (or equal) wall plate to this terminals. Set Dip Switch 8 to control a mixed signal or Input 3 signal only.
- Balanced Line Output** - Provides output for connection to balanced mic/ line level devices. **Note:** Unbalanced line level devices can be used with proper wire configuration by connecting the (G) and (-) terminals together.
- Output Limiter Control** - Sets peak output levels by increasing or decreasing the sensitivity. The Limiter LED on the front panel indicates when limiter is in use. Note: The control knob can be replaced with a supplied security cover to prevent unauthorized adjustment.
- Vox Sense** - Adjusts the sensitivity of the Mute circuit for priority pages. Set Dip Switch 8 to control a mixed signal or Input 3 signal only.
- Cable Management Retainer Points** - Use rear panel screws to secure included cable management retainers.





### Dip Switch Function Identification

SWITCH FUNCTIONS

1	2	3	4	5	6	7	8
INPUT 1	INPUT 2	INPUT 1	INPUT 1 125Hz/12dB LOW CUT	INPUT 2	INPUT 2 125Hz/12dB LOW CUT	INPUT 3 MUTE RCV	REMOTE LEVEL
PHANTOM			OFF	LINE	OFF	OFF	MIXED
OFF	OFF	LINE	OFF	LINE	OFF	OFF	MIXED
ON	ON	MIC	ON	MIC	ON	ON	INPUT 3

### Switch Position

- DIP SW # 1,2 - 24VDC Phantom Power applies power for condenser mic operation to corresponding input terminal. Down position is On.
- DIP SW # 3 - Input Mic or Line Select for input gain selection for Input 1. Up position is Line, down position is Microphone.
- DIP SW # 4 - Low Cut Filter engages at 125Hz with a roll off rate of 12dB per octave. This filter operates either in the Line or Mic mode and is available on Input 1. Ideal for vocal microphones to reduce low frequency energy and to increase intelligibility. Down position is On.
- DIP SW # 5 - Input Mic or Line Select for input gain selection for Input 2. Up position is Line, down position is Microphone.
- DIP SW # 6 - Low Cut Filter engages at 125Hz with a roll off rate of 12dB per octave. This filter operates either in the Line or Mic mode and is available on Input 2. Ideal for vocal microphones to reduce low frequency energy and to increase intelligibility. Down position is On.
- DIP SW # 7 - Input 3 Mute Receive will mute audio present at Input 3 when audio is present at Input 1. Down position is On.
- DIP SW # 8 - Remote Level sets whether the remote volume control adjusts all inputs mixed or Input 3 only. Up position is all inputs, down position is Input 3 only.

### Cable Management

All TSD models feature a simple but effective cable management system. Each TSD is shipped with two cable wrap ties. Remove one of the screws on the rear of the TSD run the screw thru the cable wrap tie head and resecure the screw. Wrap the tie around the cables.

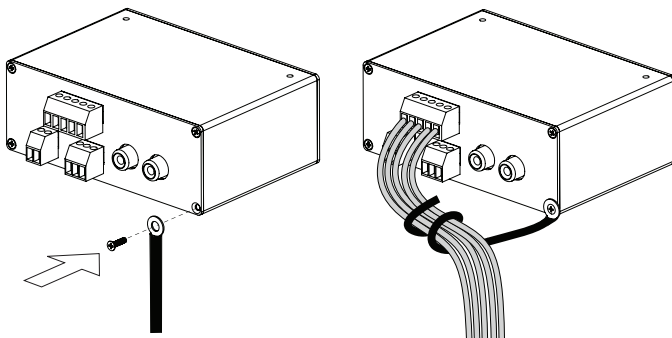

1601 Jack McKay Blvd. • Ennis, Texas 75119 U.S.A.  
Telephone: 800.876.3333 • Fax: 800.765.3435



## Knob and Security Cover

All front panel level controls feature a removable knob that can be replaced with an included security cover. Follow these steps to prevent potentiometer damage or unwanted changes.

1. Knob Installation - Turn the potentiometer shaft fully counter-clockwise. Align the knob indicator to the lowest setting on the panel and the potentiometer shaft slot. Carefully press the knob onto the potentiometer shaft. Do not force or damage may occur to the potentiometer.

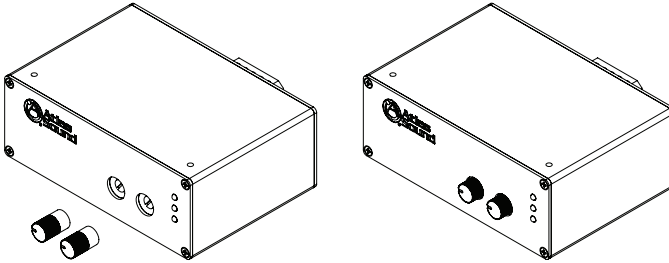

2. Security Cover Installation - Remove the knob from the panel and insert the cover. Small pliers may be required to remove the knobs. Align the security cover to the level control panel hole. Push the cover into the hole until it snaps into place. Do not force or damage may occur to the potentiometer.

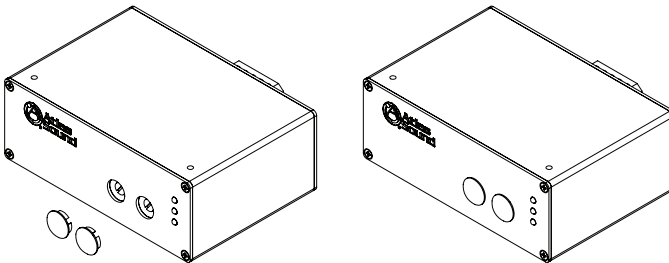



### Mounting

Listed below are the ways to mount the TSD and the optional accessories that can be purchased.

1. Velcro™ - Each unit includes two 2" x 2" pieces of industrial-grade Velcro™ with adhesive backing to adhere to any flat surface. Clean all surfaces before applying the adhesive side of the Velcro™.

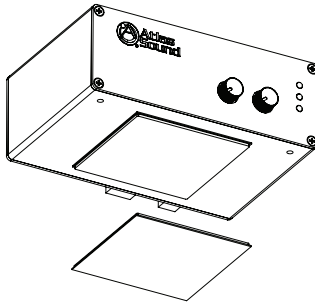

2. Multi Mount Plate - Each TSD includes a versatile multi-position mounting plate. This plate allows the TSD to be mounted to any surface; but is ideal for use with rear rack rails or side rack hat channels. Use the included M3 x 4mm screws to install the plate on the TSD. **Note:** Only use the included M3 x 4mm screws as other screws may be too long and will cause internal damage to the TSD. The multi-position mounting plate is a new addition being included with TSDs. If the TSD being used did not include the mounting plate, contact Atlas customer service at 1-800-876-3333.

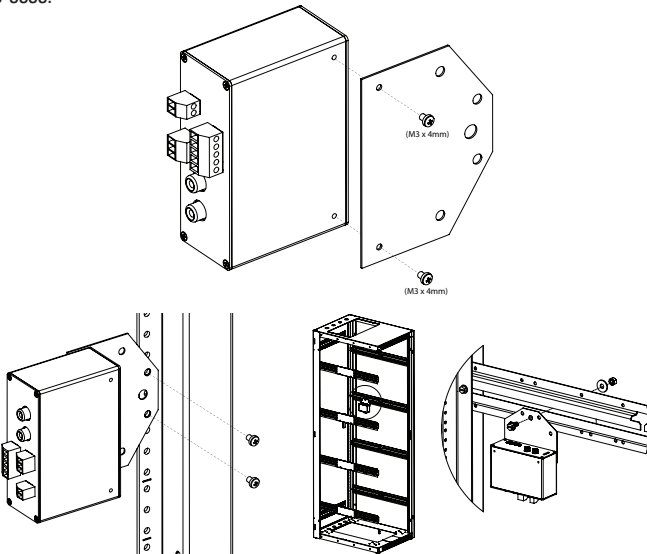

1601 Jack McKay Blvd. • Ennis, Texas 75119 U.S.A.  
Telephone: 800.876.3333 • Fax: 800.765.3435



### Optional Mounting Accessories

1. TSD-RMK 19" Width Rack Mount Kit - For 19" rack mounting, Atlas Sound offers an optional rack mount kit, the TSD-RMK. This rack mount kit can support up to four TSD units. The kit includes three blank panels designed to fill any unused slots. Use the included hardware to mount the TSD into the rack mount kit using the top mount screw holes on the TSD.

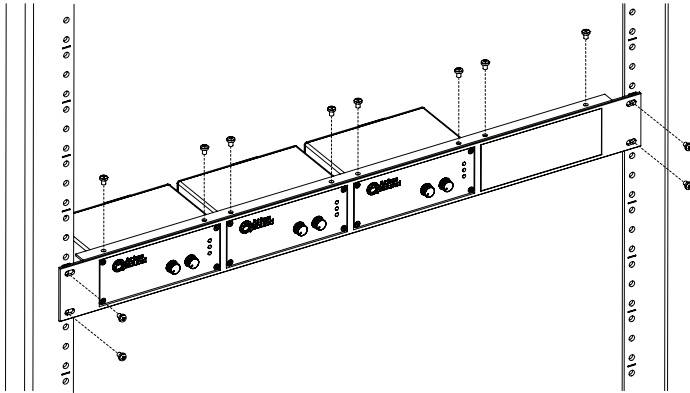

2. TSD-RMKHR Half Width Rack Mount Kit - Atlas Sound offers an optional rack mount kit that can be used in half width rack applications including the Atlas Sound WMA-HR and AWR-HR models. The TSD-RMKHR can support up to two TSDs. Included is an extra blank panel to fill one of the spaces if only one TSD is being used.

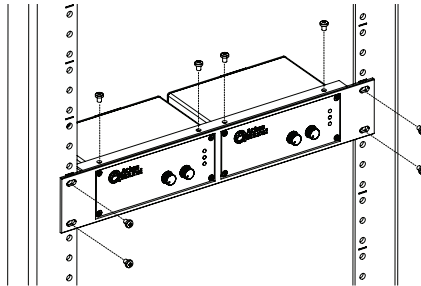





3. TSD-RRMK Rear Rack Mounting Kit - For complete flexibility in mounting a TSD or TSD external power supplies the optional TSD-RRMK is available. The TSD-RRMK can support mounting of either two larger TSDs with external power supplies or up to 4 TSD models. **Note:** Only use the included M3 x 4mm screws as other screws may be too long and will cause internal damage to the TSD.

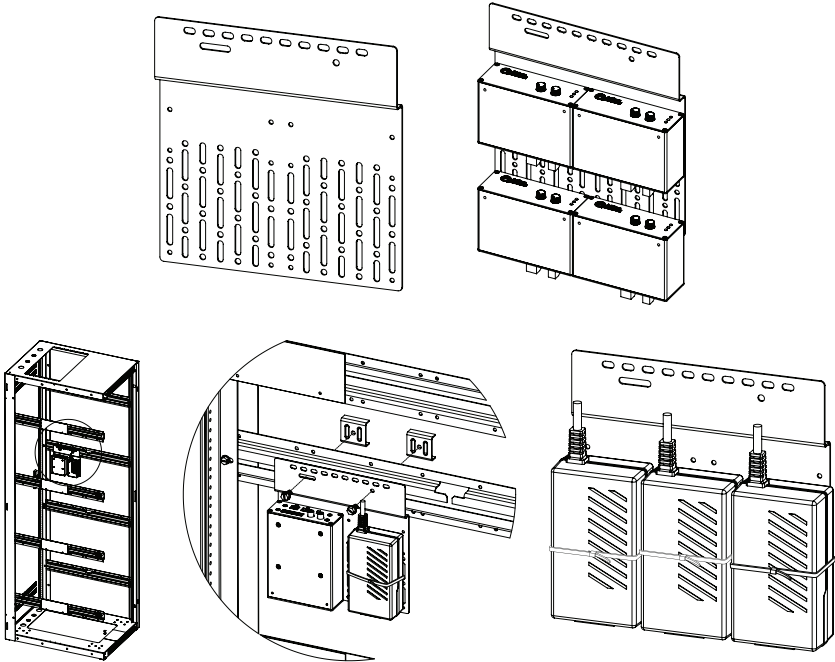

1601 Jack McKay Blvd. • Ennis, Texas 75119 U.S.A.  
Telephone: 800.876.3333 • Fax: 800.765.3435



# TSD-MIX31RL 3x1 Mic/Line Mixer

## Owner's Manual

### Block Diagram

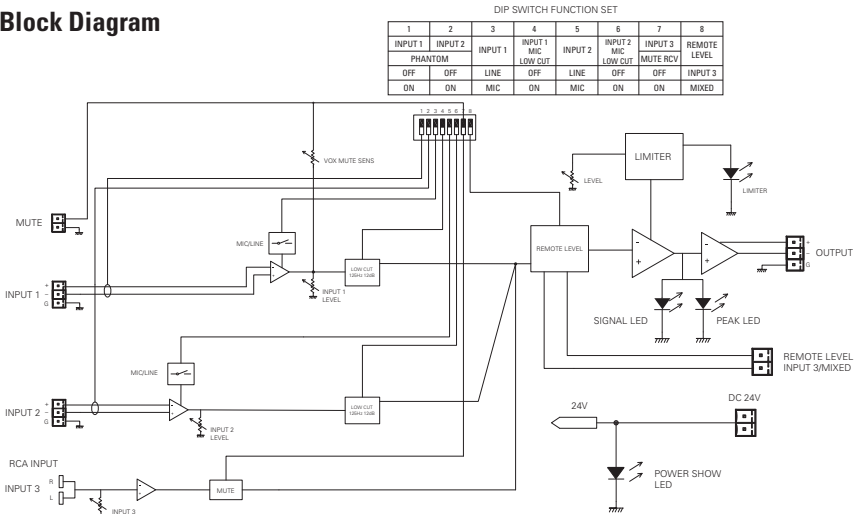

### Specifications

<b>Description</b>	3 x 1 Mic/Line Mixer
<b>Chassis Color</b>	Black
<b>Chassis Material</b>	Aluminum
<b>Inputs</b>	
Type	Qty 1, Unbalanced
Connection	RCA Left and Right Actively Summed
Impedance	10KΩ
Input Level	316mV (-10dBV) = 2V (+6dBV) Balanced Output, Maximum Input 1.6V (4.1dBV)
Type	Qty 2, Balanced Mic or Line Selectable
Connection	Removable 3 Position Captive Screw 3.5mm Spacing
Impedance	1.2KΩ Balanced, 600Ω Unbalanced
Phantom	24VDC Defeatable
Low Cut Filter	125Hz/12dB Defeatable
Line Input Level	1V (0dBV) Balanced = 2V (+6dBV) Balanced Output, Maximum Input 6V (6dBV)
Mic Input Level	46dB Gain, 10mV (-40dB) Balanced = 2V (+6dBV) Balanced Output, Maximum Input 40mV (-27dBV)
<b>Outputs</b>	
Type	Qty 1, Balanced Line
Connection	Removable 3 Position Captive Screw 3.5mm Spacing
Impedance	300Ω Balanced, 150Ω Unbalanced
Line Output Level	1V (0dBV) In = 2V (+6dBV), Maximum Output 6V (15dBV)



1601 Jack McKay Blvd. • Ennis, Texas 75119 U.S.A.  
Telephone: 800.876.3333 • Fax: 800.765.3435



### Controls

Input Level Control	Qty 3, Removable Knobs with Security Covers
Output Level Control	Qty 1, Removable Knob with Security Cover
Mute Input 3	Contact Closure, Removable 2 Position Captive Screw 3.5mm Spacing Trim Adjust for Mic Sensitivity
VOX Mute Sens	Threshold Adjust
Output Limiter	Control Port 10K External Pot, Removable 2 Position Captive Screw 3.5mm Spacing
Remote Level	• Phantom Power 24VDC, Input 1 & 2 • Input 1 & 2, Mic/Line Select • Input 1 & 2, 125Hz/12dB High Pass Filter • Input 3, Mute Receive • Remote Level Assign, Mix or Input 3
Dip Switch Function	

### Indicators

Input Signal	Green, 25mV On Threshold
Input Peak	Red, -3dB Before Clip
Limiter	Red, Limiter Activation
Power	Blue

### Electrical

Frequency Response	20Hz - 20kHz ( $\pm 1$ dB)
THD	.06% & 1kHz
Signal to Noise	Line to Line: 85dBV Mic to Line: 78dBV
Output Limiter	Threshold Adjust 50mV Minimum Output to No Limit

### Power Requirements

Voltage	24VDC
Power Consumption	60mA
Power Consumption	1.4W

Dimensions H 1.5" (39mm) x W 4" (101mm) x D 2.75" (70mm)

Weight 6oz, .165kg

### Included Accessories

Velcro™	Industrial-Grade
Multi-Mount Plate	Qty 1, Includes Two (2) M3 x 4mm Screws
Cable Retainer	Qty 2
Level Control Knobs	Qty 4
Level Control Security Covers	Qty 4

### Optional Accessories

TSD 24VDC	Power Supply
TSD-RMK	1 RU 19" Width Rack Mount Panel (Supports 4 TSD Units)
TSD-RMKHR	1 RU Half Rack Width Panel (Supports 2 TSD Units)
TSD-RRMK	Rear Rack Mounting Kit

### Safety and Certifications

External Power Supply	cUL, CE, RoHS, TUV
-----------------------	--------------------



1601 Jack McKay Blvd. • Ennis, Texas 75119 U.S.A.  
Telephone: 800.876.3333 • Fax: 800.765.3435



## Limited Warranty

All products manufactured by Atlas Sound are warranted to the original dealer/installer, industrial or commercial purchaser to be free from defects in material and workmanship and to be in compliance with our published specifications, if any. This warranty shall extend from the date of purchase for a period of three years on all Atlas Sound products, including SOUNDOLIER brand, and ATLAS SOUND brand products except as follows: one year on electronics and control systems; one year on replacement parts; and one year on Musician Series stands and related accessories. Additionally, fuses and lamps carry no warranty. Atlas Sound will solely at its discretion, replace at no charge or repair free of charge defective parts or products when the product has been applied and used in accordance with our published operation and installation instructions. We will not be responsible for defects caused by improper storage, misuse (including failure to provide reasonable and necessary maintenance), accident, abnormal atmospheres, water immersion, lightning discharge, or malfunctions when products have been modified or operated in excess of rated power, altered, serviced or installed in other than a workman like manner. The original sales invoice should be retained as evidence of purchase under the terms of this warranty. All warranty returns must comply with our returns policy set forth below. When products returned to Atlas Sound do not qualify for repair or replacement under our warranty, repairs may be performed at prevailing costs for material and labor unless there is included with the returned product(s) a written request for an estimate of repair costs before any nonwarranty work is performed. In the event of replacement or upon completion of repairs, return shipment will be made with the transportation charges collect.

EXCEPT TO THE EXTENT THAT APPLICABLE LAW PREVENTS THE LIMITATION OF CONSEQUENTIAL DAMAGES FOR PERSONAL INJURY, ATLAS SOUND SHALL NOT BE LIABLE IN TORT OR CONTRACT FOR ANY DIRECT, CONSEQUENTIAL OR INCIDENTAL LOSS OR DAMAGE ARISING OUT OF THE INSTALLATION, USE OR INABILITY TO USE THE PRODUCTS. THE ABOVE WARRANTY IS IN LIEU OF ALL OTHER WARRANTIES INCLUDING BUT NOT LIMITED TO WARRANTIES OF MERCHANTABILITY AND FITNESS FOR A PARTICULAR PURPOSE.

Atlas Sound does not assume, or does it authorize any other person to assume or extend on its behalf, any other warranty, obligation, or liability. This warranty gives you specific legal rights and you may have other rights which vary from state to state.

## Service

Should your Atlas TSD require service, please contact the Atlas Sound warranty department at 1-877-689-8055, ext. 1274 to obtain an RA number.

Atlas Sound Tech Support can be reached at 1-800-876-3333.

Visit our website at [www.AtlasSound.com](http://www.AtlasSound.com) to see other Atlas products

©2014 Atlas Sound L.P. All rights reserved. Atlas Sound is a trademark of Atlas Sound L.P.  
All other trademarks are the property of their respective owners. ATSO03941 RevC 1/14



1601 Jack McKay Blvd. • Ennis, Texas 75119 U.S.A.  
Telephone: 800.876.3333 • Fax: 800.765.3435