

Kramer Electronics, Ltd.

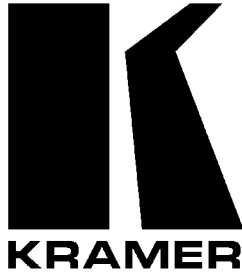

USER MANUAL

Model:

VP-43xl

Interface Converter

Contents

1	Introduction	1
2	Getting Started	1
3	Overview	1
4	Your Interface Converter	3
5	Connecting a Interface Converter Unit	4
5.1	Connecting a PC (RS-232)	5
5.2	Connecting the RS-485 Connector	5
5.3	Understanding the RS-422 Connector	6
5.3.1	Signal Terminology	6
5.3.2	Bi-directional Signals	6
5.3.3	Communication Method via a DB9 Connector	6
5.3.4	Device Definition	7
5.3.5	Port Definitions	7
5.3.6	More Than One Slave	7
5.4	Connecting the RS-422 Connector	9
5.5	Dipswitch Settings	9
5.6	Interface Converter Unit Configuration	10
5.6.1	Fully transparent RS-232 Daisy Chaining	11
6	Using the Interface Converter as a Range Extender	13
7	Technical Specifications	14

Figures

Figure 1:	Range of Bi-directional Converted Interface Signals	2
Figure 2:	VP-43xl Interface Converter	4
Figure 3:	Connecting a PC without using a Null-modem Adapter	5
Figure 4:	RS-485 Connector PINOUT	5
Figure 5:	Bi-directional Signals I	6
Figure 6:	Bi-directional Signals II	6
Figure 7:	Communication between a Master and several Slaves	8
Figure 8:	SETUP Dipswitches	10
Figure 9:	PC control of 2 Switchers via RS-232 and RS-485	10
Figure 10:	PC control of up to 32 Switchers via RS-485	11
Figure 11:	PC control of a Broadcasting VTR Unit via RS-422	11
Figure 12:	PC control of Broadcasting VTR Units via RS-232 and RS-422	12
Figure 13:	Control of up to 32 VTR Units via RS-485 and RS-422	12
Figure 14:	Control via RS-485, RS-422 and RS-232	13
Figure 15:	Extending the Range using a Pair of Interface Converter Units	14

Tables

Table 1:	Features and Functions of the VP-43xl Interface Converter	4
Table 2:	Baud Rate Selection	9
Table 3:	SETUP Dipswitch Definitions	9
Table 4:	Technical Specifications of the VP-43xl Interface Converter	14

1 Introduction

Dedication by Kramer Electronics since 1981, to the development and manufacture of high quality video/audio equipment, makes the Kramer line an integral part of the finest production and presentation facilities in the world. In recent years, Kramer has redesigned and upgraded most of the line, making the best even better! The Kramer line of professional video/audio electronics is one of the most versatile and complete available, and is a true leader in terms of quality, workmanship, price/performance ratio and innovation. In addition to our high quality accessories, like the **VP-43xl Interface Converter**, we also offer excellent switchers and matrices, distribution amplifiers, presentation processors, interfaces, remote controllers and computer-related products.

Congratulations on purchasing your Kramer Tools **VP-43xl Interface Converter**. This product is ideal for:

- Interconnecting units with different control interfaces
- Extending the limited range of RS -232 by converting to RS-422 or RS-485
- Daisy-chaining RS-422 devices

The package includes the following items:

- **VP-43xl** Interface Converter
- Power adapter (12V DC Input)
- Mounting bracket
- This user manual
- Kramer concise product catalog/CD

2 Getting Started

We recommend that you:

- Unpack the equipment carefully and save the original box and packaging materials for possible future shipment
- Review the contents of this user manual

3 Overview

Your easy to use **VP-43xl Interface Converter** incorporates the 3 major video and presentation industry interfaces: RS -232, RS-422 and RS-485. The

RS-232¹ interface is a computer interface with a range of about 25 meters used for a point-to-point connection. The RS-422² interface is commonly used in broadcasting equipment and has a range of 1200 meters usually used for a point-to-point connection (but can be used for transmitting from one unit to several Slave receivers). The RS-485³ interface has a range of 1200 meters and lets you connect up to 32 devices to one line.

The adjustment-free **VP-43xl Interface Converter** accepts serial data on one interface, automatically translating it simultaneously to the other 2 interfaces with the same speed and format. Each way is bi-directional, as Figure 1 illustrates:

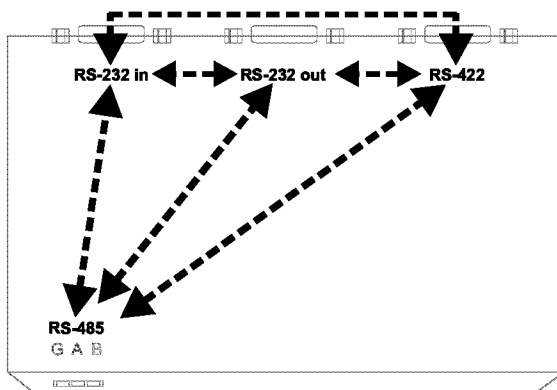

Figure 1: Range of Bi-directional Converted Interface Signals

The **VP-43xl Interface Converter** can control equipment with different interfaces, from a piece of equipment with a single interface⁴. In particular, the **VP-43xl Interface Converter** lets you control equipment with:

- An RS-422 or RS-485 interface directly from the COM port (RS-232) on your PC⁵
- An RS-232 or RS-485 interface from a controller with an RS-422 interface
- An RS-232 or RS-422 interface from any modern equipment with an RS-485 interface

1 The RS-232 interface meets the TIA/EIA-232-F standard

2 The RS-422 interface meets the TIA/EIA-422-B standard

3 The RS-485 interface meets the TIA/EIA-485-A standard

4 For example, you can control a switcher with a RS-232 interface and a broadcasting VTR with a RS-422 interface, from a controller with an RS-485 interface

5 Without requiring a PC interface card adapter

The **VP-43xl Interface Converter**:

- Is a Plug & Play device¹
- Avoids the limitation of RS-232 and RS-422 interfaces that allow only a point-to-point connection (that is, one device per port)
- Enables fully transparent RS-232 daisy-chaining²
- Supports varied setup arrangements³
- Lets you connect up to 32 units via the RS-485 interface⁴
- Can extend the range between a PC and a switcher to up to 1200 meters⁵

The **VP-43xl Interface Converter** lets you choose a:

- Connection with or without a Null-modem adapter for RS-232
- Baud rate from a choice of 5 rates⁶
- RS-422 Master/Slave and a Straight/Inverse interface

Achieving the best performance means:

- Connecting only good quality connection cables, thus avoiding interference, deterioration in signal quality due to poor matching, and elevated noise levels (often associated with low quality cables)
- Avoiding interference from neighboring electrical appliances that may adversely influence signal quality and positioning your **VP-43xl Interface Converter** unit in a location free from moisture and away from excessive sunlight and dust

4 Your Interface Converter

Figure 1 and Table 1 define the **VP-43xl Interface Converter** unit:

1 Unlike many control interfaces, it is not software reliant

2 Using multiple VP-43xl Interface Converter units, as section 5.6.1 describes

3 As the illustrations in section 5 show

4 As Figure 10, Figure 13 and Figure 14 illustrate

5 When connecting a pair of VP-43xl Interface Converter units via RS-485, as section 6 describes

6 1,200 baud, 2,400 baud, 9,600 baud, 19,200 baud, or 38,400 baud

Connecting a Interface Converter Unit

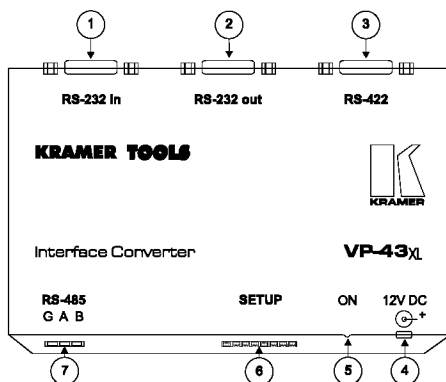

Figure 2: VP-43xl Interface Converter

Table 1: Features and Functions of the VP-43xl Interface Converter

#	Feature	Function
1	RS-232 in DB9F Port	Connect to the DB 9 COM PORT 1-4 on the PC or controller
2	RS-232 out DB9F Port	Connect to the RS-232 DB 9 port on the switcher, VTR, mixer or to the RS-232 in port on the next <i>Interface Converter</i> in the line
3	RS-422 DB9F Port	Connect to the RS-422 port on the controller or broadcasting VTR
4	12V DC	+12V DC connector for powering the unit
5	ON LED	Illuminates when receiving power
6	SETUP	Set the dipswitches
7	RS-485	Connect to the RS-485 port on the switcher or controller

5 Connecting a Interface Converter Unit

To connect the **VP-43xl Interface Converter** unit, do the following¹:

- Connect a DB 9 flat-cable to the *RS-232 in* port, if control via a PC is required (for example, when using the Kramer Control software or other controller), as section 5.1 describes
- Connect a DB 9 flat-cable to the *RS-232 out* port, if required
- Connect a RS-485 terminal block connector cable if control via RS-485 is required, as section 5.2 describes
- Connect a DB 9 flat-cable to the *RS-422* port, if control via RS-422 is required, as section 5.4 describes
- Set the SETUP dipswitches as section 5.5 describes
- Connect the supplied 12V DC power adapter to the power socket and connect the adapter to the mains electricity

¹ Switch OFF the power on each device before connecting it to your VP-43xl Interface Converter unit. After connecting your VP-43xl Interface Converter unit, switch on its power and then switch on the power on each device

5.1 Connecting a PC (RS-232)

To connect a PC to the **VP-43xl Interface Converter** unit, **do not use a Null-modem adapter**. Do one of the following:

- For a 9 pin COM port (DB9): Connect the RS-232 port on your PC to the *RS-232 in* DB9F port on the **VP-43xl Interface Converter** unit, with a one-to-one flat-cable connection; or
- For a 25 pin COM port (DB25): Connect the RS-232 port on your PC to the *RS-232 in* DB9F port on the **VP-43xl Interface Converter** unit, as Figure 3 illustrates

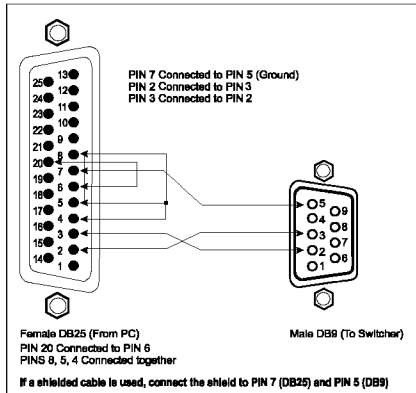

Figure 3: Connecting a PC without using a Null-modem Adapter

5.2 Connecting the RS-485 Connector

Figure 4 defines the RS-485 connector PINOUT for RS-485 control:

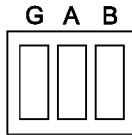

Figure 4: RS-485 Connector PINOUT

To connect the **VP-43xl** unit's RS-485 connector, do the following:

1. Connect the "A" (+) PIN on the first **VP-43xl Interface Converter** unit to the "A" (+) PIN on another **VP-43xl Interface Converter** unit¹ or on a switcher or controller²

1 As Figure 9 and Figure 10 illustrate

2 As Figure 13 and Figure 14 illustrate

2. Connect the “B” (-) PIN on the first **VP-43xl Interface Converter** unit to the “B” (-) PIN on the other **VP-43xl Interface Converter** unit or on a switcher or controller
3. Connect the “G” (Ground) PIN to the shield if using a shielded cable.

5.3 Understanding the RS-422 Connector

Sections 5.3.1 to 5.3.6 describe RS-422 functionality.

5.3.1 Signal Terminology

- Connections are between *Master* and *Slave* or *Controller* and *Controlled devices*, rather than the regular *In* and *Out* or *Source* and *Destination* devices. The difference is not merely one of semantics but a vital distinction when trying to understand the concept of RS-422 technology
- With a regular *In* and *Out* switcher, not only does the front panel have separate *In* and *Out* buttons but the rear panel also has separate ports for input and output connectors
- With a *Master* and *Slave* control switcher, the front panel has separate *Master* and *Slave* buttons but the rear panel has shared *Master / Slave* connectors

5.3.2 Bi-directional Signals

- By using a pair of conductors, each signal travels in both directions via a balanced line between *Master / Slave* devices, as Figure 5 illustrates:

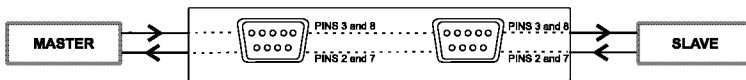

Figure 5: Bi-directional Signals I

- When a *Master* device changes position with a *Slave* device, the pins change, as Figure 6 illustrates:

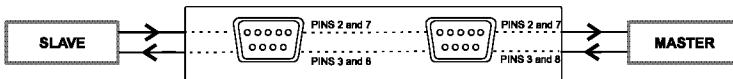

Figure 6: Bi-directional Signals II

- Set DIP 8, as Table 3 defines, to assign PINS 2 and 7 and PINS 3 and 8

5.3.3 Communication Method via a DB9 Connector

- The *Master* unit usually sends a command to the *Slave* device via pins 3(+) and 8(-) and the *Slave* device responds to the *Master* via pins 2(-) and 7(+)

- Keep the communication path clear between the Master and Slave units in both directions, as the Slave device must respond to a command transmitted by the Master
- If the Master receives no response from the Slave, the Master may cancel the communication with the Slave machine and will sometimes flag a message: *no communication*. For example, in video production when a special controller (with play and rewind functionality) is the Master device, each command transmitted to the Slave device must reach that Slave device and that Slave device must respond, otherwise the Master device will disconnect the communication

5.3.4 Device Definition

- In many broadcast applications, different machines involved in production can be either Slaves or Masters. Using a device as a Master means that the device transmits via pins 3 and 8 and receives via pins 2 and 7. In some other setup that uses the same device as a Slave, this will mean that the device transmits via pins 2 and 7 and receives via pins 3 and 8
- For example, an edit controller always works as a Master. During an editing session, a VTR may be the Slave to the edit controller. However, in a duplication setup, the VTR may become a Master for a second VTR. Configure the **VP-43xl Interface Converter**, as a Slave, by setting DIP 8 OFF. Configure the **VP-43xl Interface Converter** as a Master, by setting DIP 8 ON

5.3.5 Port Definitions

- Modern equipment usually has only one connector, RS-422, which functions as a Master as well as a Slave
- Some older broadcast equipment contains 3 RS-422 connectors; RS-422-In, RS-422-Out and RS-422-In/Out. You can only connect a Master to an RS-422-In port and you can only connect an RS-422-Out port to a Slave. When connecting to an RS-422-In/Out port¹ the unit changes dynamically, automatically reconfiguring the DB9 port pins to be either a Master or a Slave

5.3.6 More Than One Slave

- Communication between one Master and one Slave is simple. However, communication between one Master and several Slaves, for example, in duplication applications, is more complicated, as Figure 7 illustrates.

¹ Item 1 in Table 2

Connecting an Interface Converter Unit

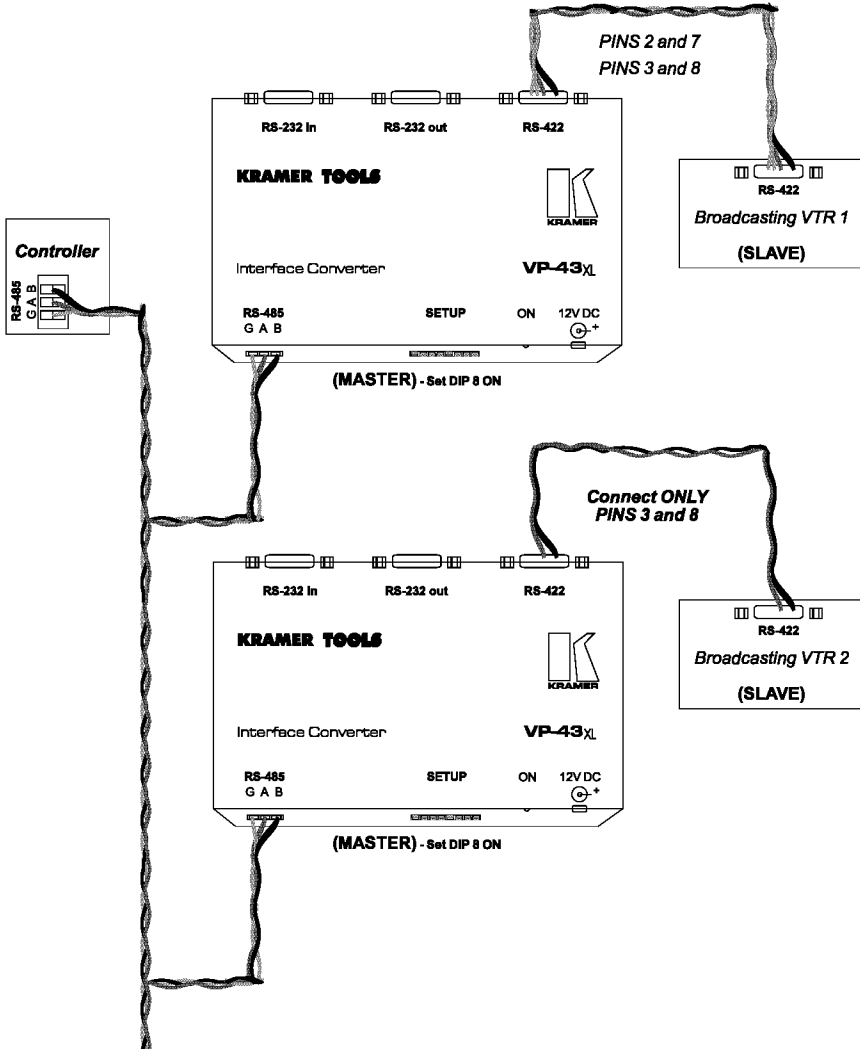

Up to 32

Figure 7: Communication between a Master and several Slaves

5.4 Connecting the RS-422 Connector

To connect the **VP-43xl Interface Converter** unit's RS-422 DB9F port:

- Connect the RS-422 DB9F port on the **VP-43xl Interface Converter** unit to the RS-422 DB9F port on the controller¹ or Broadcasting VTR²
- Set DIPS 7 and 8, as required³

5.5 Dipswitch Settings

Configure the **VP-43xl Interface Converter** by setting the 8 SETUP dipswitches, as Table 2, Table 3 and Figure 8 define:

Table 2: Baud Rate Selection

Baud	DIP 1	DIP 2	DIP 3	DIP 4	DIP 5
1,200	ON	OFF	OFF	OFF	OFF
2,400	OFF	ON	OFF	OFF	OFF
9,600	OFF	OFF	ON	OFF	OFF
19,200	OFF	OFF	OFF	ON	OFF
38,400	OFF	OFF	OFF	OFF	ON

Table 3: SETUP Dipswitch Definitions

DIP	SET:
6	ON for a straight wire connection ⁴ between the RS-232 out port (transmit to pin 2, receive at pin 3) and the switcher or other acceptor
	OFF for a crossed wire connection ⁵ between the RS-232 out port (transmit to pin 3, receive at pin 2) and the switcher or other acceptor
7	ON for a non-inverted signal connection between the RS-422 port and certain broadcasting VTR units
	OFF for an inverted signal connection between the RS-422 port and certain broadcasting VTR units ⁶
8	ON for a Master connection between the RS-422 port and the broadcasting VTR unit (transmits via pins 3 and 8, receives via pins 2 and 7) ⁷
	OFF for a Slave connection between the RS-422 port and the broadcasting VTR unit (transmits via pins 2 and 7 and receives via pins 3 and 8) ⁷

1 As Figure 14 illustrates

2 As Figure 12 and Figure 13 illustrate

3 Refer to section 5.3

4 For example, flat cable

5 Null-modem

6 The inverted connection is required for some VTR's (for example, Sony)

7 Refer to sections 5.3.2 and 5.3.4

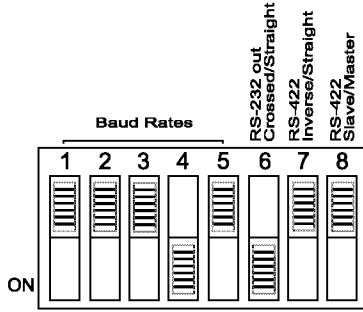

Figure 8: *SETUP Dipswitches*

As Figure 8 illustrates, the Baud rate is set at 19,200 (DIP 4 ON) with a straight wire connection between the RS-232 out port and the switcher (DIP 6 ON), as well as an inverse wire connection between the RS-422 port and a broadcasting VTR unit (DIP 7 OFF). In addition, there is a Slave connection between the RS-422 port and the broadcasting VTR unit (DIP 8 OFF).

5.6 Interface Converter Unit Configuration

The following illustrations¹ show some of the varied ways in which you can connect the **VP-43xI** *Interface Converter* unit:

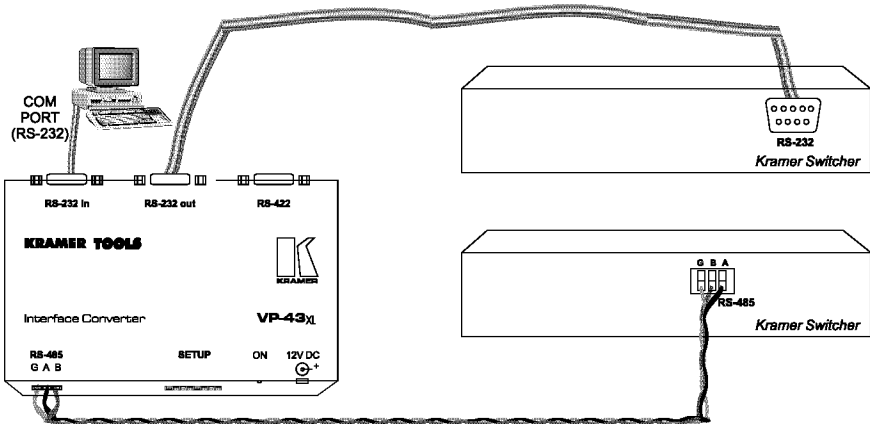

Figure 9: *PC control of 2 Switchers via RS-232 and RS-485*

¹ Figure 9 to Figure 14 inclusive

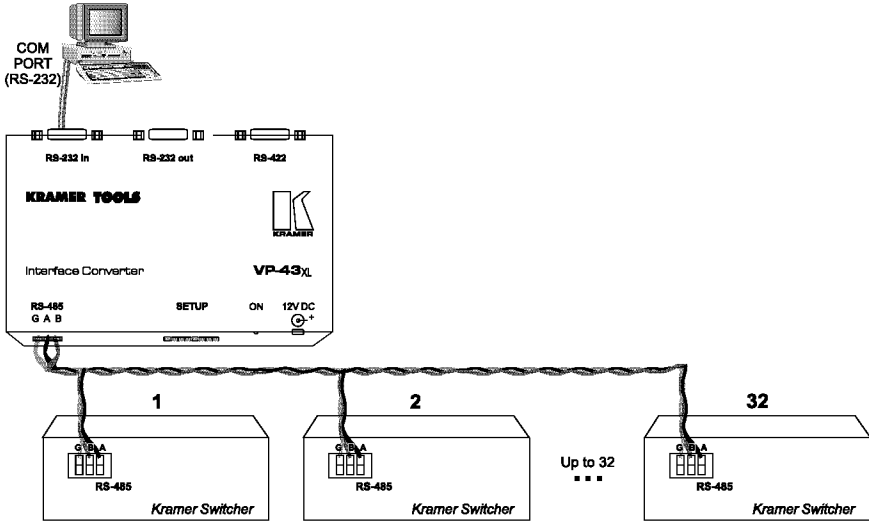

Figure 10: PC control of up to 32 Switches via RS-485

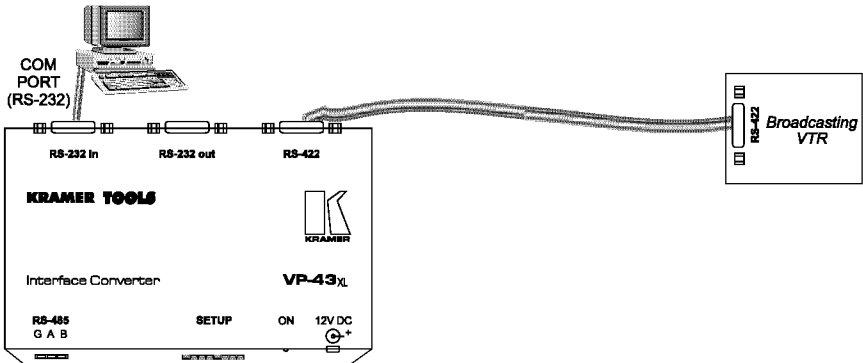

Figure 11: PC control of a Broadcasting VTR Unit via RS-422

5.6.1 Fully transparent RS-232 Daisy Chaining

The **VP-43xl Interface Converter**, with its RS-232 in and RS-232 out connectors, facilitates fully transparent RS-232 daisy-chaining of multiple **VP-43xl Interface Converter** units. Each **VP-43xl Interface Converter** unit connects to a proprietary RS-422 controlled machine, as Figure 12 illustrates.

Connecting an Interface Converter Unit

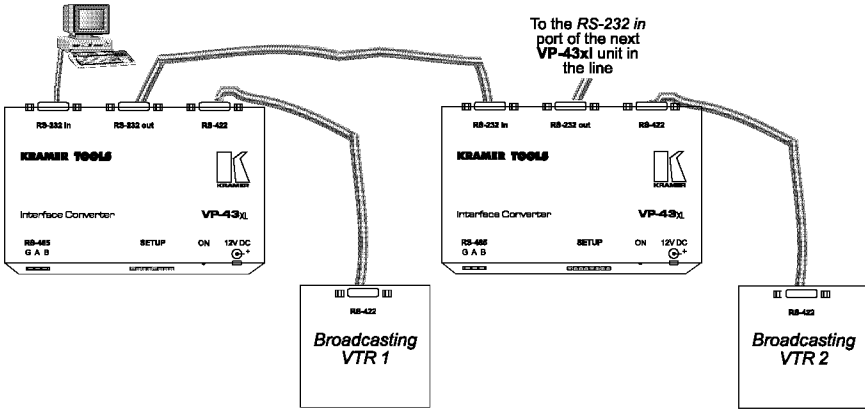

Figure 12: PC control of Broadcasting VTR Units via RS-232 and RS-422

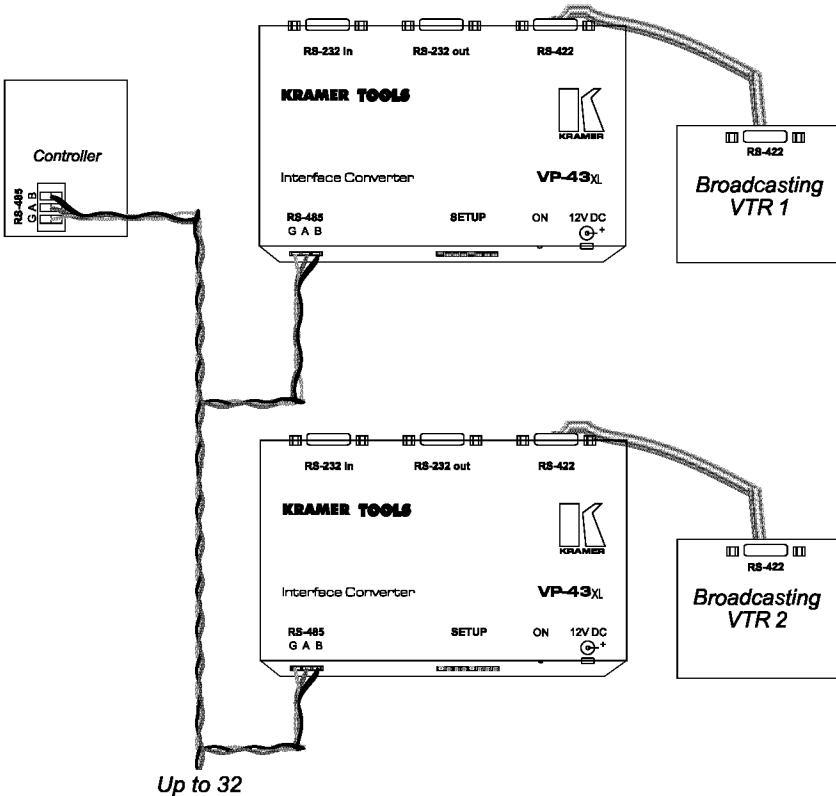

Figure 13: Control of up to 32 VTR Units via RS-485 and RS-422

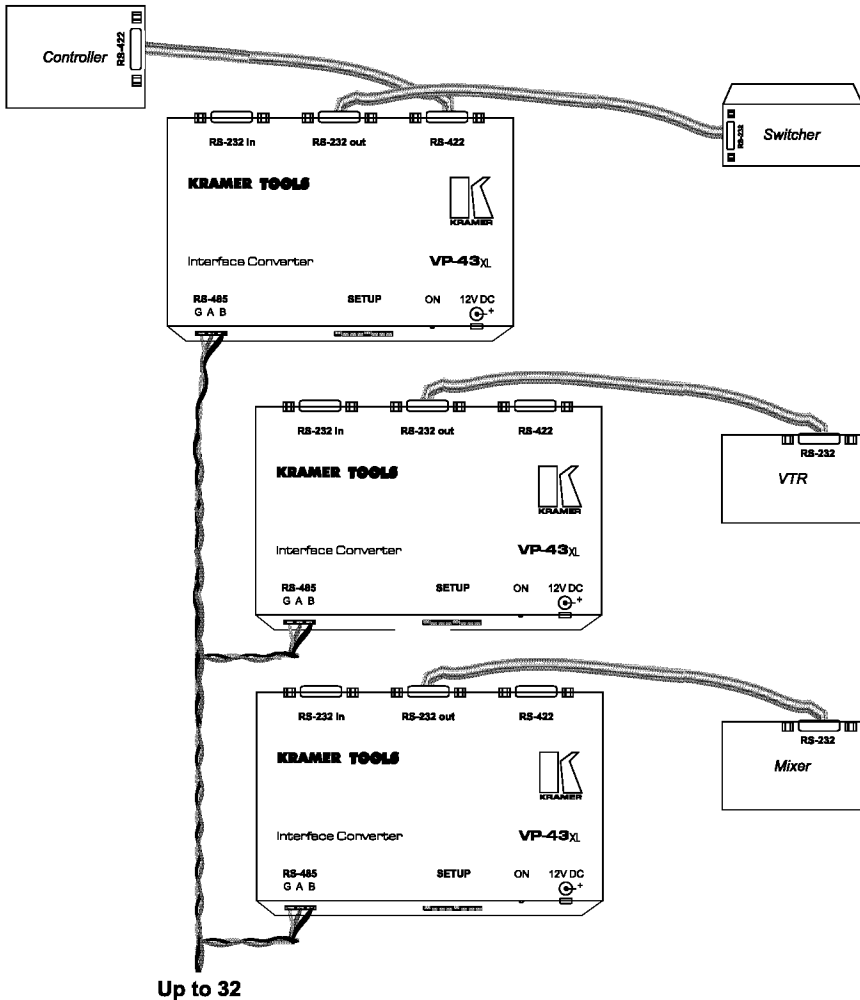

Figure 14: Control via RS-485, RS-422 and RS-232

6 Using the Interface Converter as a Range Extender

To extend the RS-232 range (between, say, a PC and a switcher) you can use a pair of VP-43xl Interface Converter units, as Figure 15 illustrates. Set up as follows:

1. Connect the RS-232 in port on the first VP-43xl unit to the PC's RS-232 DB9 COM port.

2. Connect the RS-232 out port on the second VP-43xl unit to the switcher's RS-232 DB 9M port.
3. Connect the RS-485 port on the first VP-43xl unit to the RS-485 port on the second VP-43xl unit.
4. Set the dipswitches as required (refer to Table 3).
5. Connect the 12V DC power adapter to the power socket and connect the adapter to the mains electricity, separately, for each VP-43xl unit.
6. Switch on the PC and the switcher.
The PC can operate the switcher from an extended distance of up to 1000 meters.

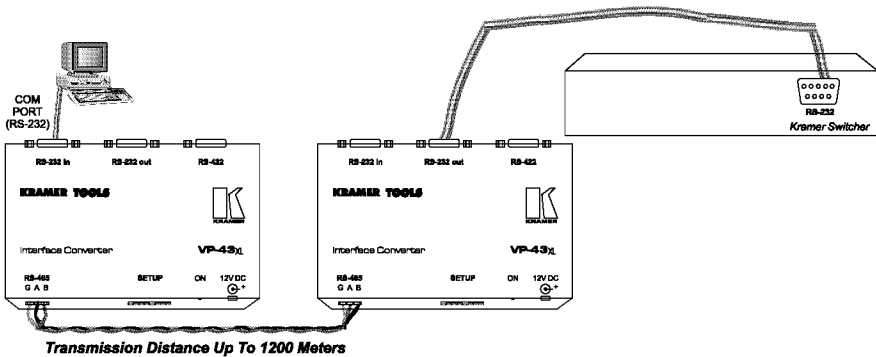

Figure 15: Extending the Range using a Pair of Interface Converter Units

7 Technical Specifications

Table 4 includes the technical specifications:

Table 4: Technical Specifications of the VP-43xl Interface Converter

Inputs/Outputs:	RS-232 IN on a DB-9F connector, RS-232 OUT on a DB-9M connector compliant to TIA/EIA-232-F RS-485 3 wires detachable terminal block compliant to TIA/EIA-485-A RS-422 DB-9F compliant to TIA/EIA-422-B
Baud Rates:	1200, 2400, 9600, 19200, 38400
Format:	1 Start bit, 8 data bits, 1 Stop bit
Display:	Power ON LED
Dimensions:	12 cm x 7.5 cm x 2.5 cm (4.7" x 0.98" x 2.95"), W, D, H
Power Source:	12 VDC, 80 mA
Weight:	0.3 kg. (0.67 lbs.) approx.
Options:	19" rack adapters RK-T1, RK-T3

LIMITED WARRANTY

Kramer Electronics (hereafter *Kramer*) warrants this product free from defects in material and workmanship under the following terms.

HOW LONG IS THE WARRANTY

Labor and parts are warranted for three years from the date of the first customer purchase.

WHO IS PROTECTED?

Only the first purchase customer may enforce this warranty.

WHAT IS COVERED AND WHAT IS NOT COVERED

Except as below, this warranty covers all defects in material or workmanship in this product. The following are not covered by the warranty:

1. Any product which is not distributed by Kramer, or which is not purchased from an authorized Kramer dealer. If you are uncertain as to whether a dealer is authorized, please contact Kramer at one of the agents listed in the web site www.kramerelectronics.com.
2. Any product, on which the serial number has been defaced, modified or removed.
3. Damage, deterioration or malfunction resulting from:
 - i) Accident, misuse, abuse, neglect, fire, water, lightning or other acts of nature
 - ii) Product modification, or failure to follow instructions supplied with the product
 - iii) Repair or attempted repair by anyone not authorized by Kramer
 - iv) Any shipment of the product (claims must be presented to the carrier)
 - v) Removal or installation of the product
 - vi) Any other cause, which does not relate to a product defect
 - vii) Cartons, equipment enclosures, cables or accessories used in conjunction with the product

WHAT WE WILL PAY FOR AND WHAT WE WILL NOT PAY FOR

We will pay labor and material expenses for covered items. We will not pay for the following:

1. Removal or installations charges.
2. Costs of initial technical adjustments (set-up), including adjustment of user controls or programming. These costs are the responsibility of the Kramer dealer from whom the product was purchased.
3. Shipping charges.

HOW YOU CAN GET WARRANTY SERVICE

1. To obtain service on your product, you must take or ship it prepaid to any authorized Kramer service center.
2. Whenever warranty service is required, the original dated invoice (or a copy) must be presented as proof of warranty coverage, and should be included in any shipment of the product. Please also include in any mailing a contact name, company, address, and a description of the problem(s).
3. For the name of the nearest Kramer authorized service center, consult your authorized dealer.

LIMITATION OF IMPLIED WARRANTIES

All implied warranties, including warranties of merchantability and fitness for a particular purpose, are limited in duration to the length of this warranty.

EXCLUSION OF DAMAGES

The liability of Kramer for any effective products is limited to the repair or replacement of the product at our option. Kramer shall not be liable for:

1. Damage to other property caused by defects in this product, damages based upon inconvenience, loss of use of the product, loss of time, commercial loss; or:
2. Any other damages, whether incidental, consequential or otherwise. Some countries may not allow limitations on how long an implied warranty lasts and/or do not allow the exclusion or limitation of incidental or consequential damages, so the above limitations and exclusions may not apply to you.

This warranty gives you specific legal rights, and you may also have other rights, which vary from place to place.

NOTE: All products returned to Kramer for service must have prior approval. This may be obtained from your dealer.

This equipment has been tested to determine compliance with the requirements of:

- EN-50081: "Electromagnetic compatibility (EMC);
generic emission standard.
Part 1: Residential, commercial and light industry"
- EN-50082: "Electromagnetic compatibility (EMC) generic immunity standard.
Part 1: Residential, commercial and light industry environment".
- CFR-47: FCC Rules and Regulations:
Part 15: "Radio frequency devices
Subpart B – Unintentional radiators"

CAUTION!

- ☒ Servicing the machines can only be done by an authorized Kramer technician. Any user who makes changes or modifications to the unit without the expressed approval of the manufacturer will void user authority to operate the equipment.
- ☒ Use the supplied DC power supply to feed power to the machine.
- ☒ Please use recommended interconnection cables to connect the machine to other components.



**The list of Kramer distributors appears on our web site:
www.kramerelectronics.com**

We welcome your questions, comments and feedback.

Kramer Electronics, Ltd.

3 Am VeOlamo Street, Jerusalem 95463, Israel Tel: (+972-2)-654-4000

Fax: (+972-2)-653-5369, E-mail: kramerel@netvision.net.il

P/N: 2900-006008 REV 1