

**Kramer Electronics, Ltd.**



# **USER MANUAL**

**Model:**

**F-571**

*HDMI Line Transmitter Mounting Box for*

*Ackermann Floor Boxes*

## Contents

<b>1</b>	<b>Introduction</b>	<b>1</b>
<b>2</b>	<b>Getting Started</b>	<b>1</b>
<b>3</b>	<b>Overview</b>	<b>2</b>
3.1	About the Power Connect™ Feature	4
3.2	Using Twisted Pair Cable	4
3.3	About HDMI	4
3.4	Achieving the Best Performance	5
<b>4</b>	<b>Your F-571 HDMI Line Transmitter Mounting Box</b>	<b>6</b>
<b>5</b>	<b>Installing the F-571</b>	<b>7</b>
5.1	Installing a Kramer Insert	7
5.2	Connecting the Cables to the Rear Side of the F-571	7
5.3	Installing the F-571 inside the Ackermann Floor Box	8
5.4	Connecting the Front Panel Ports	9
5.5	Wiring the 9-pin Terminal Block Line Output Connector	9
5.6	Wiring the CAT 5 LINE IN / LINE OUT RJ-45 Connectors	10
<b>6</b>	<b>Technical Specifications</b>	<b>10</b>

## Figures

Figure 1:	The F-571 HDMI Line Driver Mounting Box	3
Figure 2:	F-571 Fitted in an Ackermann Floor Box	3
Figure 3:	F-571 HDMI Line Transmitter Mounting Box	6
Figure 4:	Installing the F-571 HDMI Line Transmitter Mounting Box	8
Figure 5:	Terminal Block Pinouts	9
Figure 6:	CAT 5 PINOUT	10

## Tables

Table 1:	F-571 Features	6
Table 2:	CAT 5 PINOUT	10
Table 3:	Technical Specifications of the F-571	10

## 1 Introduction

Welcome to Kramer Electronics! Since 1981, Kramer Electronics has been providing a world of unique, creative, and affordable solutions to the vast range of problems that confront the video, audio, presentation, and broadcasting professional on a daily basis. In recent years, we have redesigned and upgraded most of our line, making the best even better! Our 1,000-plus different models now appear in 11 groups<sup>1</sup> that are clearly defined by function.

Thank you for purchasing the Kramer **F-571 HDMI Line Transmitter Mounting Box** for Ackermann floor boxes, which is ideal for:

- Presentation venues
- Multimedia applications
- Long range graphics distribution for schools, hospitals, security, and stores

The **F-571** includes two single Kramer inserts<sup>2</sup> and is mounted on Ackermann flush floor service units that accept GB2 GB3 size boxes<sup>3</sup>.

The package includes the following items:

- **F-571**
- Power adapter (12V DC Input) and this user manual<sup>4</sup>

## 2 Getting Started

We recommend that you:

- Unpack the equipment carefully and save the original box and packaging materials for possible future shipment
- Review the contents of this user manual
- Use Kramer high-performance high-resolution cables<sup>5</sup>

---

1 GROUP 1: Distribution Amplifiers; GROUP 2: Switchers and Matrix Switchers; GROUP 3: Control Systems; GROUP 4: Format/Standards Converters; GROUP 5: Range Extenders and Repeaters; GROUP 6: Specialty AV Products; GROUP 7: Scan Converters and Scalers; GROUP 8: Cables and Connectors; GROUP 9: Room Connectivity; GROUP 10: Accessories and Rack Adapters; GROUP 11: Sierra Products

2 The complete list of Kramer products can be found on our Web site at <http://www.kramerelectronics.com>

3 GB2 and GB3 are Ackermann mounting boxes that fit into Ackermann floor boxes

4 Download up-to-date Kramer user manuals from the Internet at <http://www.kramerelectronics.com>

5 The complete list of Kramer cables is on our Web site at <http://www.kramerelectronics.com>

### 3 Overview

The **F-571** mounting box for Ackermann floor boxes is a twisted pair transmitter for HDMI signals. The **F-571** converts an HDMI signal to a single twisted pair signal that it transmits to a compatible twisted pair receiver<sup>1</sup>. The **F-571** includes two adjacent openings<sup>2</sup> (covered with blank inserts) for Kramer inserts.

In particular, the **F-571** transmitter section features:

- Maximum data rate/bandwidth up to 1.6Gbps
- HDTV compatibility and HDCP compliance
- HDMI Support – HDMI (V.1.4 with Deep Color, x.v.Color™, Lip Sync, HDMI Uncompressed Audio Channels, Dolby TrueHD, and DTS-HD)
- EDID PassThru that passes EDID/HDCP signals from source to display
- 3D pass-through
- System Range<sup>3</sup> - Up to 90m (295ft) at 1080i, or up to 30m (98ft) at 1080p on shielded **BC-DGKat524** cable; 90m (295ft) at 1080i, or up to 70m (230ft) at 1080p on shielded **BC-DGKat623** cable; 100m (330ft) at 1080i or up to 90m (295ft) at 1080p on shielded **BC-DGKat7a23** cable
- Power Connect™ that feeds 12V DC over the TP cable from transmitter to receiver (see section [3.1](#))

---

<sup>1</sup> For example, the Kramer PT-572+

<sup>2</sup> Lets you fit two single inserts or one dual insert

<sup>3</sup> Note that the transmission range depends on the signal resolution, graphics card and display used. The distance using non-Kramer CAT 5, CAT 6 and CAT 7a cables may not reach these ranges

[Figure 1](#) shows the **F-571 HDMI Line Transmitter Mounting Box**:



*Figure 1: The F-571 HDMI Line Driver Mounting Box*

[Figure 2](#) shows the **F-571** fitted in an Ackermann floor box:



*Figure 2: F-571 Fitted in an Ackermann Floor Box*

### 3.1 About the Power Connect™ Feature

The Power Connect™ feature here means that only one unit in a system, the transmitter or receiver, can be connected to a power source when the devices are within 270 feet (90 meters) of each other. The Power Connect™ feature applies as long as the cable can carry power. The distance does not exceed 90 meters on standard CAT 5 cable, for longer distances, heavy gauge cable should be used<sup>1</sup>.

### 3.2 Using Twisted Pair Cable

Kramer engineers have developed special twisted pair cables to best match our digital twisted pair products; the Kramer: **BC-DGKat524** (CAT 5 24 AWG), the Kramer: **BC-DGKat623** (CAT 6 23 AWG cable), and the Kramer: **BC-DGKat7a23** (CAT 7a 23 AWG cable). These specially built cables significantly outperform regular CAT 5/CAT 6/CAT 7a cables.

### 3.3 About HDMI

High-Definition Multimedia Interface (HDMI) is an uncompressed all-digital<sup>2</sup> audio/video interface, widely supported in the entertainment and home cinema industry. It delivers the highest high-definition image and sound quality. Note that Kramer Electronics Limited is an HDMI Adopter and an HDCP Licensee.

In particular, HDMI:

- Provides a simple<sup>3</sup> interface between any audio/video source, such as a set-top box, DVD player, or A/V receiver and video monitor, such as a digital flat LCD/plasma television (DTV), over a single lengthy<sup>4</sup> cable
- Supports standard, enhanced, high-definition video, and multi-channel digital audio<sup>5</sup> on a single cable
- Transmits all ATSC HDTV standards and supports 8-channel digital audio, with bandwidth to spare to accommodate future enhancements and requirements

---

1 CAT 5 cable is still suitable for the video/audio transmission, but not for feeding the power at these distances

2 Ensuring an all-digital rendering of video without the losses associated with analog interfaces and their unnecessary digital-to-analog conversions

3 With video and multi-channel audio combined into a single cable, the cost, complexity, and confusion of multiple cables currently used in A/V systems is reduced

4 HDMI technology has been designed to use standard copper cable construction at up to 15m

5 HDMI supports multiple audio formats, from standard stereo to multi-channel surround-sound HDMI has the capacity to support Dolby 5.1 audio and high-resolution audio formats

- Benefits consumers by providing superior, uncompressed digital video quality via a single cable<sup>1</sup>, and user-friendly connector
- Is backward-compatible with DVI (Digital Visual Interface)
- Supports two-way communication between the video source (such as a DVD player) and the digital television, enabling new functionality such as automatic configuration and one-button play

HDMI has the capacity to support existing high-definition video formats (720p, 1080i, and 1080p/60), as well as standard definition formats such as NTSC or PAL.

### 3.4 Achieving the Best Performance

To achieve the best performance:

- Use only good quality connection cables<sup>2</sup> to avoid interference, deterioration in signal quality due to poor matching, and elevated noise levels (often associated with low quality cables)
- Avoid interference from neighboring electrical appliances that may adversely influence signal quality and position your Kramer devices away from moisture, excessive sunlight and dust

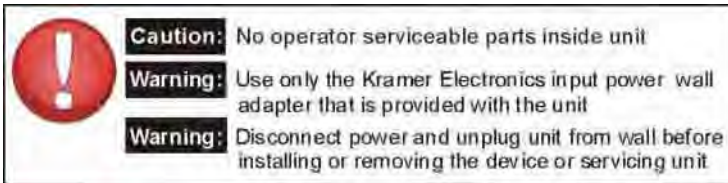

---

<sup>1</sup> HDMI provides the quality and functionality of a digital interface while also supporting uncompressed video formats in a simple, cost-effective manner

<sup>2</sup> Available from Kramer Electronics on our Web site at <http://www.kramerelectronics.com>

## 4 Your F-571 HDMI Line Transmitter Mounting Box

[Figure 3](#) and [Table 1](#) define the **F-571**:

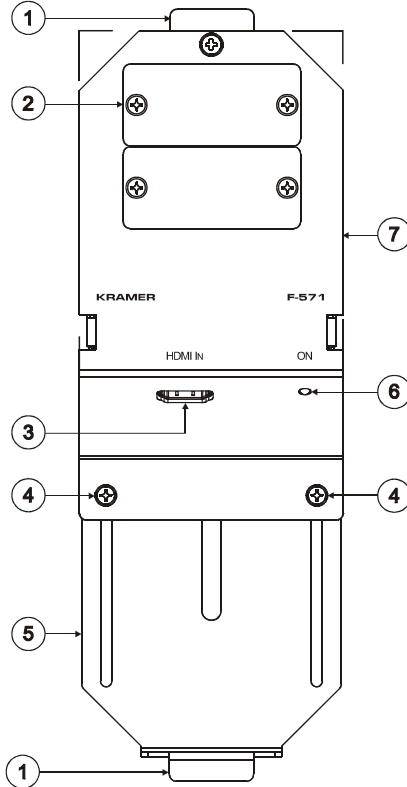

Figure 3: F-571 HDMI Line Transmitter Mounting Box

Table 1: F-571 Features

#	Feature	Function
1	Mounting Tabs	For fitting the <b>F-571</b> into an Ackermann floor box
2	Blank Inserts (2)	Replace with Kramer wall plate inserts (see section <a href="#">5.1</a> )
3	HDMI IN Connector	Connect to the HDMI source
4	Slide Screws (2)	Release to increase or decrease the length of the unit; tighten to fix size
5	Adjustable Mounting Slide	For adjusting the size of the unit to fit an Ackermann floor box
6	ON LED	Lights red when receiving power only, orange when input and power are attached, and yellow when both an active input and output are attached
7	9-pin Terminal Block Line Output Connector <sup>1</sup>	Connect to the line in connector on the receiver (see section <a href="#">5.5</a> )

<sup>1</sup> Located inside the mounting box



## 5 Installing the F-571

To install the **F-571** you have to install the inserts and the transmitter which is connected via TP to a receiver.

To install the **F-571**, do the following:

- Install the Kramer inserts (see section [5.1](#))
- Connect the cables to the rear side (see section [5.2](#))
- Install the **F-571** inside the Ackermann floor box (see section [5.3](#))
- Connect the front panel ports (see section [5.4](#))
- Connect the twisted pair cable to the receiver (for example, the Kramer **PT-572+**)

### 5.1 Installing a Kramer Insert

To install a Kramer insert, do the following:

1. Unscrew the two screws holding the blank insert and remove it.
2. Place and align the required wall plate insert item over the opening.
3. Insert the two screws to fix the insert in place, and tighten them.

### 5.2 Connecting the Cables to the Rear Side of the F-571

To connect the rear side cables, do the following:

1. Run the cables through the Ackermann underfloor cable opening.
2. Connect the cables to the rear side of the inserts.
3. Connect the cables to the rear side of the **F-571** transmitter, that is, attach the:
  - Terminal block line output of the **F-571** to the pre-installed UTP wiring that connects to the TP receiver<sup>1</sup>, see section [5.5](#)
  - 12V DC power supply to the power terminal blocks (connect the wire labeled “+” to the +12V pin, and the wire labeled “-” to the GND pin) taking care that the polarity is correct (see [Figure 5](#))

---

<sup>1</sup> For example, the Kramer PT-572+ HDMI Line Receiver

### 5.3 Installing the F-571 inside the Ackermann Floor Box

To install the **F-571** inside the Ackermann floor box, as illustrated in [Figure 4](#), perform the following steps:

1. Slightly release the two slide screws (do not remove them) to let the adjustable mounting slide move freely.
2. Fit the **F-571** mounting frame into its designated place inside the Ackermann floor box (see [Figure 2](#)).
3. Insert the fixed tab into the slot in the Ackermann box.
4. Adjust the size of the unit to fit the space in the box.
5. Insert the tab on the adjustable mounting frame to the appropriate slot in the Ackermann box.
6. Tighten slide screws to fix the size of the unit.

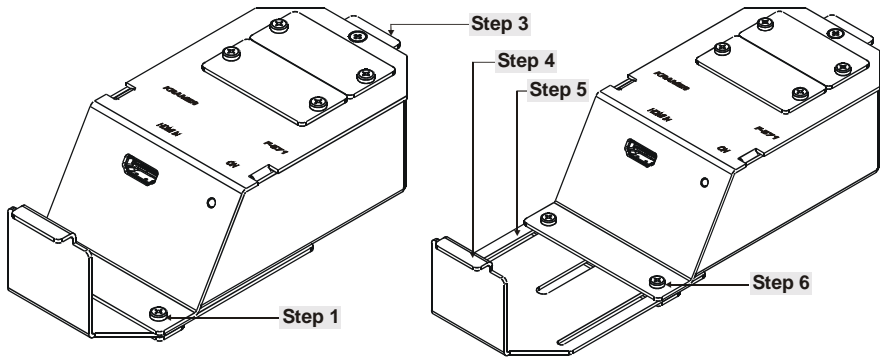

Figure 4: Installing the F-571 HDMI Line Transmitter Mounting Box

## 5.4 Connecting the Front Panel Ports

1. On the **F-571** transmitter section, connect an HDMI source (for example, a DVD player) to the HDMI IN connector.
2. Connect the appropriate connectors to the inserts.

## 5.5 Wiring the 9-pin Terminal Block Line Output Connector

The 9-pin terminal block, inside the mounting box, is an easy plug-in connector for attaching the UTP cable. Follow the colors of the color-coded sticker on these terminals for proper connection of the UTP cable. [Figure 5](#) defines the pinouts for the terminal block.

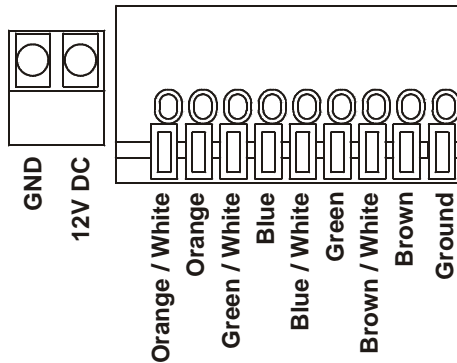

Figure 5: Terminal Block Pinouts

### Notes:

- Use the connector clips only when removing wires, not when inserting them
- Each wire should protrude 9mm (0.35") from the plastic insulation so that it can be easily connected. To prevent the wires crossing, be sure that each wire is fully inserted

## 5.6 Wiring the CAT 5 LINE IN / LINE OUT RJ-45 Connectors

[Table 2](#) and [Figure 6](#) define the UTP CAT 5 PINOUT, on the RJ-45 connector:

Table 2: CAT 5 PINOUT

EIA /TIA 568A		EIA /TIA 568B	
PIN	Wire Color	PIN	Wire Color
1	Green / White	1	Orange / White
2	Green	2	Orange
3	Orange / White	3	Green / White
4	Blue	4	Blue
5	Blue / White	5	Blue / White
6	Orange	6	Green
7	Brown / White	7	Brown / White
8	Brown	8	Brown
Pair 1	4 and 5	Pair 1	4 and 5
Pair 2	3 and 6	Pair 2	1 and 2
Pair 3	1 and 2	Pair 3	3 and 6
Pair 4	7 and 8	Pair 4	7 and 8

Figure 6: CAT 5 PINOUT

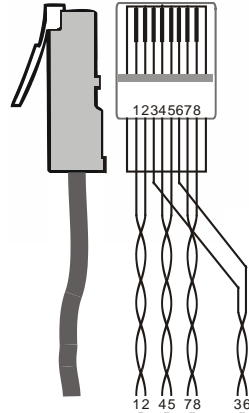

## 6 Technical Specifications

[Table 3](#) lists the technical specifications:

Table 3: Technical Specifications<sup>1</sup> of the F-571

INPUTS:	1 HDMI connector 1 Power 12V DC on 2-pin terminal block
OUTPUTS:	1 UTP on a 9-pin terminal block with springs
BANDWIDTH:	Supports up to 1.65Gbps bandwidth per graphic channel
COMPLIANCE WITH HDMI STANDARD:	Supports HDMI and HDCP
CONTROLS:	Signal detection LED
POWER SOURCE:	12V DC, 250mA
DIMENSIONS:	Closed: 7.5cm x 15.7cm x 4.4cm (2.95" x 6.18" x 1.73") W, D, H Open: 7.5cm x 15.7cm x 4.4cm (2.95" x 6.18" x 1.73") W, D, H
WEIGHT:	0.18 kg (0.4lbs)
ACCESSORIES:	Power supply
OPTIONS:	Kramer BC-DGKat524 (CAT 5 24 AWG), BC-DGKat623 (CAT 6 23 AWG) and BC DGKat7a23 (CAT 7a 23 AWG) cables <sup>2</sup> , 19" RK-4PT rack adapter

<sup>1</sup> Specifications are subject to change without notice

<sup>2</sup> The complete list of Kramer cables is on our Web site at <http://www.kramerelectronics.com>

---

## LIMITED WARRANTY

Kramer Electronics (hereafter *Kramer*) warrants this product free from defects in material and workmanship under the following terms

### HOW LONG IS THE WARRANTY

Labor and parts are warranted for three years from the date of the first customer purchase

### WHO IS PROTECTED?

Only the first purchase customer may enforce this warranty

### WHAT IS COVERED AND WHAT IS NOT COVERED

Except as below, this warranty covers all defects in material or workmanship in this product. The following are not covered by the warranty:

- 1 Any product which is not distributed by Kramer, or which is not purchased from an authorized Kramer dealer. If you are uncertain as to whether a dealer is authorized, please contact Kramer at one of the agents listed in the Web site [www.kramerelectronics.com](http://www.kramerelectronics.com)
- 2 Any product, on which the serial number has been defaced, modified or removed, or on which the WARRANTY VOID IF TAMPERED sticker has been torn, reattached, removed or otherwise interfered with
- 3 Damage, deterioration or malfunction resulting from:
  - i) Accident, misuse, abuse, neglect, fire, water, lightning or other acts of nature
  - ii) Product modification, or failure to follow instructions supplied with the product
  - iii) Repair or attempted repair by anyone not authorized by Kramer
  - iv) Any shipment of the product (claims must be presented to the carrier)
  - v) Removal or installation of the product
  - vi) Any other cause, which does not relate to a product defect
  - vii) Cartons, equipment enclosures, cables or accessories used in conjunction with the product

### WHAT WE WILL PAY FOR AND WHAT WE WILL NOT PAY FOR

We will pay labor and material expenses for covered items. We will not pay for the following:

- 1 Removal or installation charges
- 2 Costs of initial technical adjustments (set-up), including adjustment of user controls or programming. These costs are the responsibility of the Kramer dealer from whom the product was purchased
- 3 Shipping charges

### HOW YOU CAN GET WARRANTY SERVICE

- 1 To obtain service on your product, you must take or ship it prepaid to any authorized Kramer service center
- 2 Whenever warranty service is required, the original dated invoice (or a copy) must be presented as proof of warranty coverage, and should be included in any shipment of the product. Please also include in any mailing a contact name, company, address, and a description of the problem(s)
- 3 For the name of the nearest Kramer authorized service center, consult your authorized dealer

### LIMITATION OF IMPLIED WARRANTIES

All implied warranties, including warranties of merchantability and fitness for a particular purpose, are limited in duration to the length of this warranty

### EXCLUSION OF DAMAGES

The liability of Kramer for any effective products is limited to the repair or replacement of the product at our option. Kramer shall not be liable for:

- 1 Damage to other property caused by defects in this product, damages based upon inconvenience, loss of use of the product, loss of time, commercial loss; or
- 2 Any other damages, whether incidental, consequential or otherwise. Some countries may not allow limitations on how long an implied warranty lasts and/or do not allow the exclusion or limitation of incidental or consequential damages, so the above limitations and exclusions may not apply to you

This warranty gives you specific legal rights, and you may also have other rights, which vary from place to place

**NOTE:** All products returned to Kramer for service must have prior approval. This may be obtained from your dealer

This equipment has been tested to determine compliance with the requirements of:

- EN-50081: "Electromagnetic compatibility (EMC);  
generic emission standard  
Part 1: Residential, commercial and light industry"
- EN-50082: "Electromagnetic compatibility (EMC) generic immunity standard  
Part 1: Residential, commercial and light industry environment"
- CFR-47: FCC\* Rules and Regulations:  
Part 15: "Radio frequency devices  
Subpart B Unintentional radiators"

### CAUTION!

- Servicing the machines can only be done by an authorized Kramer technician. Any user who makes changes or modifications to the unit without the expressed approval of the manufacturer will void user authority to operate the equipment
- Use the supplied DC power supply to feed power to the machine
- Please use recommended interconnection cables to connect the machine to other components  
\* FCC and CE approved using STP cable (for twisted pair products)



---

**For the latest information on our products and a list of Kramer distributors, visit our Web site: [www.kramerelectronics.com](http://www.kramerelectronics.com) where updates to this user manual may be found. We welcome your questions, comments and feedback.**



**Caution**

**Safety Warning:**

Disconnect the unit from the power supply before opening/servicing.



---

**Kramer Electronics, Ltd.**

Web site: [www.kramerelectronics.com](http://www.kramerelectronics.com)

E-mail: [info@kramerel.com](mailto:info@kramerel.com)

**P/N: 2900-000713 REV 1**