



KRAMER ELECTRONICS LTD.

USER MANUAL

MODEL:

VS-24x1
Video-Audio Standby Switcher

P/N: 2900-002068 Rev 5

VS-24xl Quick Start Guide

This page guides you through a basic installation and first-time use of your **VS-24xl**. For more detailed information, see the **VS-24xl** User Manual. You can download the latest manual at <http://www.kramerelectronics.com>.

Step 1: Check what's in the box

- VS-24xl** Video Standby Switcher
- 1 Power supply (12V DC)
- 4 Rubber feet
- 1 Quick Start sheet
- 1 User Manual

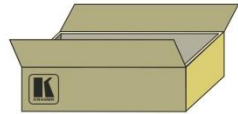

Save the original box and packaging in case you need to return your **VS-24xl** to the factory for service.

Step 2: Install the VS-24xl

Attach the rubber feet and place on a table or mount the machine in a rack (using an optional RK-1 rack mount).

Step 3: Connect the inputs and outputs

Always switch off the power on each device before connecting it to your **VS-24xl**.

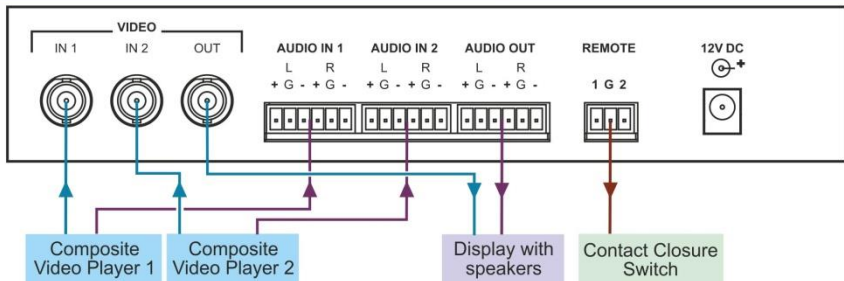

Always use Kramer high-performance cables for connecting AV equipment to the **VS-24xl**.

Step 4: Connect the power

Connect the 12V DC power adapter to the **VS-24xl** and plug the adapter into the mains electricity.



Step 5: Operate the VS-24xl

Select the input and operating mode from the front panel buttons. Adjust the EQ and LEVEL with a small screwdriver as needed.

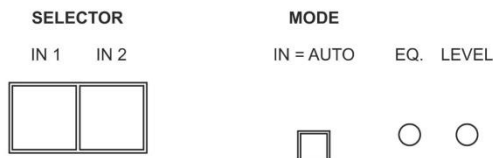

Contents

1	Introduction	1
2	Getting Started	2
2.1	Achieving the Best Performance	2
3	Overview	3
3.1	Defining the VS-24xl Video-Audio Standby Switcher	3
4	Connecting the VS-24xl	5
5	Operating the VS-24xl	7
5.1	Setting the Automatic Mode	7
5.2	Setting the Manual Mode	7
5.3	Connecting the Remote Connector	8
6	Technical Specifications	9

Figures

Figure 1:	VS-24xl Video-Audio Standby Switcher	3
Figure 2:	Connecting the VS-24xl Video-Audio Standby Switcher	6
Figure 3:	Remote Terminal Block Connector	8

1 Introduction

Welcome to Kramer Electronics! Since 1981, Kramer Electronics has been providing a world of unique, creative, and affordable solutions to the vast range of problems that confront the video, audio, presentation, and broadcasting professional on a daily basis. In recent years, we have redesigned and upgraded most of our line, making the best even better!

Our 1,000-plus different models now appear in 11 groups that are clearly defined by function: GROUP 1: Distribution Amplifiers; GROUP 2: Switchers and Routers; GROUP 3: Control Systems; GROUP 4: Format/Standards Converters; GROUP 5: Range Extenders and Repeaters; GROUP 6: Specialty AV Products; GROUP 7: Scan Converters and Scalers; GROUP 8: Cables and Connectors; GROUP 9: Room Connectivity; GROUP 10: Accessories and Rack Adapters and GROUP 11: Sierra Products.

Congratulations on purchasing your Kramer **VS-24xI** *Video-Audio Standby Switcher*, which is ideal for the following typical applications:

- Presentation systems requiring automatic selection via active wall plate inputs
- Security applications for automatic switching of control cameras
- Broadcast applications to eliminate dead air time
- Retail stores and other point-of-sale systems requiring uninterrupted demonstrations and advertising

2 Getting Started

We recommend that you:

- Unpack the equipment carefully and save the original box and packaging materials for possible future shipment
- Review the contents of this user manual
- Use Kramer high-performance, high-resolution cables



Go to www.kramerav.com to check for up-to-date user manuals, application programs, and to check if firmware upgrades are available (where appropriate).

2.1 Achieving the Best Performance

To achieve the best performance:

- Use only good quality connection cables to avoid interference, deterioration in signal quality due to poor matching, and elevated noise levels (often associated with low quality cables)
- Do not secure the cables in tight bundles or roll the slack into tight coils
- Avoid interference from neighboring electrical appliances that may adversely influence signal quality
- Position your Kramer **VS-24xl** away from moisture, excessive sunlight and dust



Caution: No operator serviceable parts inside the unit

Warning: Use only the Kramer Electronics input power wall adapter that is provided with the unit

Warning: Disconnect the power and unplug the unit from the wall before installing

3 Overview

The **VS-24xl** is a 2x1 standby switcher for composite video and balanced stereo audio signals. The **VS-24xl** is designed to automatically switch to the second input whenever the primary video signal is interrupted. If the primary signal reappears, the **VS-24xl** automatically switches back to input one.

In addition, the **VS-24xl** features:

- Operation as a simple 2x1 video and audio switcher using two front panel buttons or as a remote controlled video and audio 2x1 switcher
- A front panel button that allows the user to select between automatic and manual switching
- Video LEVEL and cable EQ. control via trimmers accessible from the front panel
- Contact closure control

3.1 Defining the VS-24xl Video-Audio Standby Switcher

This section defines the **VS-24xl**.

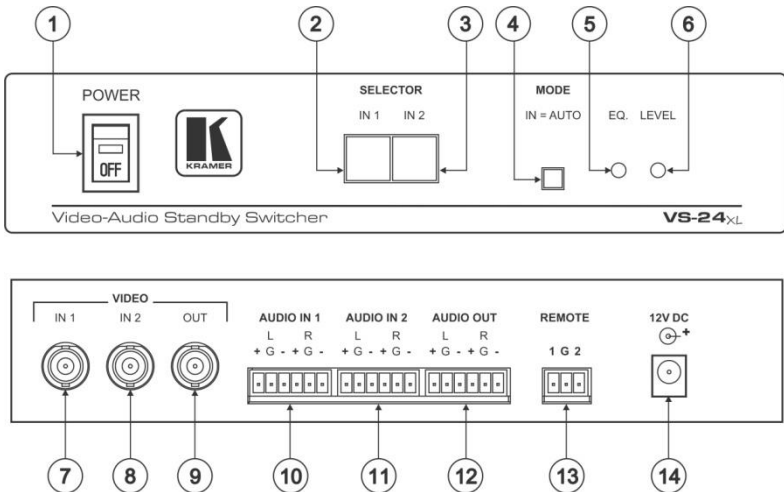

Figure 1: VS-24xl Video-Audio Standby Switcher

#	Feature	Function
1	<i>POWER</i> Switch	Illuminated switch for turning the unit ON or OFF
2	<i>SELECTOR IN 1</i> Button	In manual mode, press to switch input 1 to the output
3	<i>SELECTOR IN 2</i> Button	In manual mode, press to switch input 2 to the output
4	<i>MODE IN=AUTO</i> Button	Push in to select automatic switching, release to select manual switching
5	<i>EQ</i> Trimmer	Adjust the cable compensation equalization level Insert a screwdriver into the hole and carefully rotate it, to trim the level
6	<i>LEVEL</i> Trimmer	Adjust the output video signal level Insert a screwdriver into the hole and carefully rotate it, to trim the level
7	<i>VIDEO IN 1</i> (Master) BNC Connector	Connect to the primary video source 1
8	<i>VIDEO IN 2</i> BNC Connector	Connect to the standby video source 2
9	<i>VIDEO OUT</i> BNC Connector	Connect to the video acceptor
10	<i>AUDIO IN 1</i> (Master) Terminal Block Connector	Connect to the primary balanced audio input 1
11	<i>AUDIO IN 2</i> Terminal Block Connector	Connect to the standby balanced audio input 2
12	<i>AUDIO OUT</i> Terminal Block Connector	Connect to the balanced audio output
13	<i>REMOTE</i> Terminal Block Connector	Connect to contact closure switches
14	<i>12V DC</i>	+12V DC connector for powering the unit

4 Connecting the VS-24xl



Always switch off the power to each device before connecting it to your **VS-24xl**. After connecting your **VS-24xl**, connect its power and then switch on the power to each device.

To connect the **VS-24xl** as illustrated in the example in [Figure 2](#):

1. Connect the composite video sources to the VIDEO IN 1 (master) and IN 2 BNC connectors.
2. Connect the CV audio sources (for example, from a DVD or VCR player) to AUDIO IN 1 (master) and AUDIO IN 2 terminal blocks.
3. Connect the VIDEO OUT BNC connector to the CV input of the display.
4. Connect the AUDIO OUT terminal block connector to the balanced audio input of the speakers.
5. If needed, connect the REMOTE terminal block connector to a remote contact closure switch.



The power connection is not shown in [Figure 2](#).

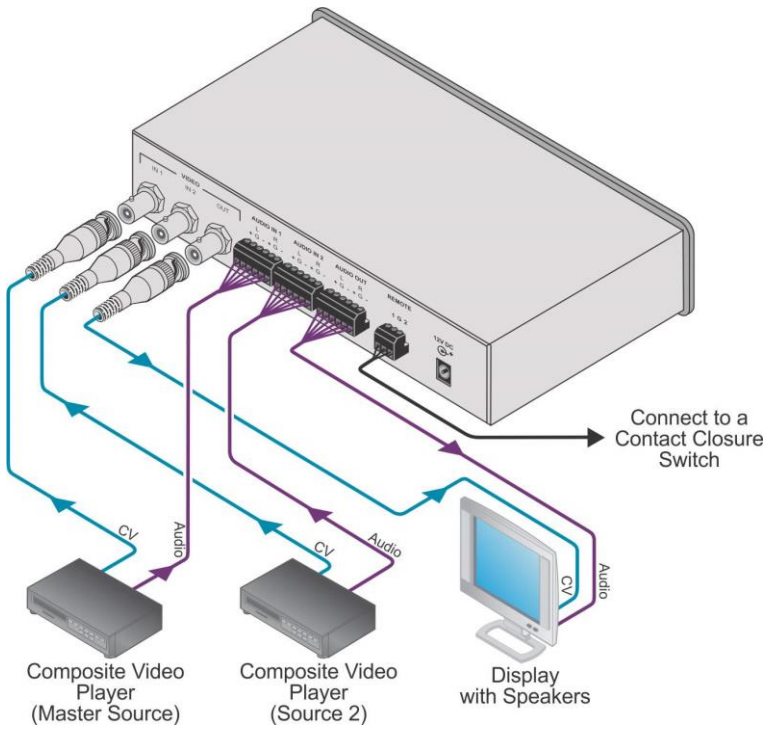

Figure 2: Connecting the VS-24xl Video-Audio Standby Switcher

5 Operating the VS-24xl

This section describes how to:

- Set the automatic mode ([Section 5.1](#))
- Set the manual mode ([Section 5.2](#))
- Connect the remote connector ([Section 5.3](#))

5.1 Setting the Automatic Mode

When the **VS-24xl** is set to the automatic mode, the signal from input 1 takes priority over the signal from input 2. If the signal from input 1 is interrupted, the signal from input 2 automatically routes to the output. In the automatic mode, pushing the SELECTOR buttons IN 1 and IN 2 has no effect.

To set the Automatic Mode:

- Push in the MODE IN=AUTO button

5.2 Setting the Manual Mode

In manual mode, you choose which input to route to the output.

To set the Manual Mode:

1. Release the MODE IN=AUTO button.
2. Press one of the SELECTOR buttons:
 - SELECTOR IN 1 (to route the signal from input 1 to the output); **or**
 - SELECTOR IN 2 (to route the signal from input 2 to the output)

5.3 Connecting the Remote Connector

In addition to its automatic switching function, the **VS-24xl** can operate as a remote controlled video and audio 2x1 switcher, by connecting contact closure switches to the appropriate REMOTE input terminal block connector pins thus forcing the routing of one of the two inputs to the output by remote control.

To do so, connect the appropriate REMOTE input terminal block connector pins to a contact closure switch and release the **MODE IN=AUTO** button. For example, as [Figure 3](#) illustrates, to route remote input 1 to the output, connect **PIN 1** to the Ground. Similarly, to route remote input 2 to the output, connect **PIN 2** to the Ground. Do not connect both the remote input 1 and the remote input 2 to the Ground simultaneously.

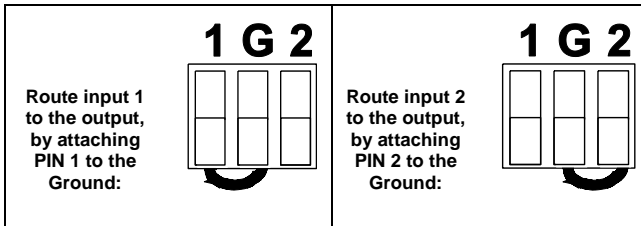

Figure 3: Remote Terminal Block Connector

When both input 1 and input 2 are connected, the (valid) signal from remote input 1 routes to the output. However, you can force the routing of remote input 2 to the output by attaching **PIN 2** to the ground. If no input is present on remote input 2, you can even force the routing of the output from remote input 2 (displaying a blank screen) by attaching **PIN 2** to the ground.

6 Technical Specifications

INPUTS:	2 composite video 1Vpp/75Ω on BNC connectors 2 balanced stereo audio +4dBu on detachable terminal block connectors
OUTPUTS:	1 composite video 1Vpp/75Ω on a BNC connector 1 balanced stereo audio +4dBu on a detachable terminal block connector
MAX. OUTPUT LEVEL:	Video: 2.1Vpp @100% color bars
VIDEO BANDWIDTH (-3dB):	620MHz
AUDIO BANDWIDTH (-3dB):	>65MHz (suitable for S/PDIF)
DIFF. GAIN:	0.03%
DIFF. PHASE:	0.03 Deg.
K-FACTOR:	<0.05%
S/N RATIO:	Video: 74dB; Audio: 71dB weighted
CROSSTALK (all hostile):	Video: -56.3dB Audio: -65.8dB @1kHz
CONTROLS:	Video level: -0.8 to +6.4dB; EQ: 0 to +12.8dB
AUDIO THD + NOISE:	0.019%
AUDIO 2nd HARMONIC:	0.002%
POWER CONSUMPTION:	12V DC, 90mA
OPERATING TEMPERATURE:	0° to +55°C (32° to 131°F)
STORAGE TEMPERATURE:	-45° to +72°C (-49° to 162°F)
HUMIDITY:	10% to 90%, RHL non-condensing
DIMENSIONS:	22cm x 18cm x 4.5cm (8.7" x 7" x 1.7") W, D, H (half 19", 1U)
WEIGHT:	1.2kg (2.65lbs) approx.
ACCESSORIES:	12V power supply
Specifications are subject to change without notice at www.kramerelectronics.com/	

LIMITED WARRANTY

The warranty obligations of Kramer Electronics for this product are limited to the terms set forth below:

What is Covered

This limited warranty covers defects in materials and workmanship in this product.

What is Not Covered

This limited warranty does not cover any damage, deterioration or malfunction resulting from any alteration, modification, improper or unreasonable use or maintenance, misuse, abuse, accident, neglect, exposure to excess moisture, fire, improper packing and shipping (such claims must be presented to the carrier), lightning, power surges, or other acts of nature. This limited warranty does not cover any damage, deterioration or malfunction resulting from the installation or removal of this product from any installation, any unauthorized tampering with this product, any repairs attempted by anyone unauthorized by Kramer Electronics to make such repairs, or any other cause which does not relate directly to a defect in materials and/or workmanship of this product. This limited warranty does not cover cartons, equipment enclosures, cables or accessories used in conjunction with this product.

Without limiting any other exclusion herein, Kramer Electronics does not warrant that the product covered hereby, including, without limitation, the technology and/or integrated circuit(s) included in the product, will not become obsolete or that such items are or will remain compatible with any other product or technology with which the product may be used.

How Long Does this Coverage Last

Seven years as of this printing; please check our Web site for the most current and accurate warranty information.

Who is Covered

Only the original purchaser of this product is covered under this limited warranty. This limited warranty is not transferable to subsequent purchasers or owners of this product.

What Kramer Electronics will do

Kramer Electronics will, at its sole option, provide one of the following three remedies to whatever extent it shall deem necessary to satisfy a proper claim under this limited warranty:

1. Elect to repair or facilitate the repair of any defective parts within a reasonable period of time, free of any charge for the necessary parts and labor to complete the repair and restore this product to its proper operating condition. Kramer Electronics will also pay the shipping costs necessary to return this product once the repair is complete.
2. Replace this product with a direct replacement or with a similar product deemed by Kramer Electronics to perform substantially the same function as the original product.
3. Issue a refund of the original purchase price less depreciation to be determined based on the age of the product at the time remedy is sought under this limited warranty.

What Kramer Electronics will not do Under This Limited Warranty

If this product is returned to Kramer Electronics or the authorized dealer from which it was purchased or any other party authorized to repair Kramer Electronics products, this product must be insured during shipment, with the insurance and shipping charges prepaid by you. If this product is returned uninsured, you assume all risks of loss or damage during shipment. Kramer Electronics will not be responsible for any costs related to the removal or re-installation of this product from or into any installation. Kramer Electronics will not be responsible for any costs related to any setting up this product, any adjustment of user controls or any programming required for a specific installation of this product.

How to Obtain a Remedy under this Limited Warranty

To obtain a remedy under this limited warranty, you must contact either the authorized Kramer Electronics reseller from whom you purchased this product or the Kramer Electronics office nearest you. For a list of authorized Kramer Electronics resellers and/or Kramer Electronics authorized service providers, please visit our web site at www.kramerelectronics.com or contact the Kramer Electronics office nearest you.

In order to pursue any remedy under this limited warranty, you must possess an original, dated receipt as proof of purchase from an authorized Kramer Electronics reseller. If this product is returned under this limited warranty, a return authorization number, obtained from Kramer Electronics, will be required. You may also be directed to an authorized reseller or a person authorized by Kramer Electronics to repair the product.

If it is decided that this product should be returned directly to Kramer Electronics, this product should be properly packed, preferably in the original carton, for shipping. Cartons not bearing a return authorization number will be refused.

Limitation on Liability

THE MAXIMUM LIABILITY OF KRAMER ELECTRONICS UNDER THIS LIMITED WARRANTY SHALL NOT EXCEED THE ACTUAL PURCHASE PRICE PAID FOR THE PRODUCT. TO THE MAXIMUM EXTENT PERMITTED BY LAW, KRAMER ELECTRONICS IS NOT RESPONSIBLE FOR DIRECT, SPECIAL, INCIDENTAL OR CONSEQUENTIAL DAMAGES RESULTING FROM ANY BREACH OF WARRANTY OR CONDITION, OR UNDER ANY OTHER LEGAL THEORY. Some countries, districts or states do not allow the exclusion or limitation of relief, special, incidental, consequential or indirect damages, or the limitation of liability to specified amounts, so the above limitations or exclusions may not apply to you.

Exclusive Remedy

TO THE MAXIMUM EXTENT PERMITTED BY LAW, THIS LIMITED WARRANTY AND THE REMEDIES SET FORTH ABOVE ARE EXCLUSIVE AND IN LIEU OF ALL OTHER WARRANTIES, REMEDIES AND CONDITIONS, WHETHER ORAL OR WRITTEN, EXPRESS OR IMPLIED. TO THE MAXIMUM EXTENT PERMITTED BY LAW, KRAMER ELECTRONICS SPECIFICALLY DISCLAIMS ANY AND ALL IMPLIED WARRANTIES, INCLUDING, WITHOUT LIMITATION, WARRANTIES OF MERCHANTABILITY AND FITNESS FOR A PARTICULAR PURPOSE. IF KRAMER ELECTRONICS CANNOT LAWFULLY DISCLAIM OR EXCLUDE IMPLIED WARRANTIES UNDER APPLICABLE LAW, THEN ALL IMPLIED WARRANTIES COVERING THIS PRODUCT, INCLUDING WARRANTIES OF MERCHANTABILITY AND FITNESS FOR A PARTICULAR PURPOSE, SHALL APPLY TO THIS PRODUCT AS PROVIDED UNDER APPLICABLE LAW.

IF ANY PRODUCT TO WHICH THIS LIMITED WARRANTY APPLIES IS A "CONSUMER PRODUCT" UNDER THE MAGNUSON-MOSS WARRANTY ACT (15 U.S.C.A. §2301, ET SEQ.) OR OTHER APPLICABLE LAW, THE FOREGOING DISCLAIMER OF IMPLIED WARRANTIES SHALL NOT APPLY TO YOU, AND ALL IMPLIED WARRANTIES ON THIS PRODUCT, INCLUDING WARRANTIES OF MERCHANTABILITY AND FITNESS FOR THE PARTICULAR PURPOSE, SHALL APPLY AS PROVIDED UNDER APPLICABLE LAW.

Other Conditions

This limited warranty gives you specific legal rights, and you may have other rights which vary from country to country or state to state.

This limited warranty is void if (i) the label bearing the serial number of this product has been removed or defaced, (ii) the product is not distributed by Kramer Electronics or (iii) this product is not purchased from an authorized Kramer Electronics reseller. If you are unsure whether a reseller is an authorized Kramer Electronics reseller, please visit our Web site at www.kramerelectronics.com or contact a Kramer Electronics office from the list at the end of this document.

Your rights under this limited warranty are not diminished if you do not complete and return the product registration form or complete and submit the online product registration form. Kramer Electronics thanks you for purchasing a Kramer Electronics product. We hope it will give you years of satisfaction.



For the latest information on our products and a list of Kramer distributors, visit our Web site where updates to this user manual may be found.

We welcome your questions, comments, and feedback.

Web site: www.kramerav.com

E-mail: info@kramerav.com

CE



SAFETY WARNING

Disconnect the unit from the power supply before opening and servicing



P/N: 2900-002068



Rev: 5