

The Kramer MTH-1VESA Adapter Plate

Congratulations on purchasing your Kramer **MTH-1 VESA Adapter Plate** for mounting Kramer **TOOLS™**, Pico **TOOLS®** and Mega**TOOLS®** on the rear panel of large displays. The **MTH-1** consists of a range of VESA standard hole-patterns that are fit for mounting on the rear side of various TV sets.

The **MTH-1 VESA Adapter Plate** includes:

- One connecting plate
- Four M3x10 screws
- Four M3 nuts
- Four M3 spring washers

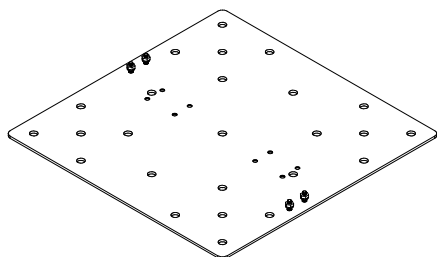

Figure 1: MTH-1 VESA Adapter Plate

Installation

To mount the **TOOL** on the **MTH-1 VESA Adapter Plate**, you need to use the brackets in the bracket kit that was supplied with your **TOOL**.



Note that the inner side (the side facing the TV) of the **MTH-1** has screw-hole indentations, while on its external side, the screw-holes appear flat.

1. Take out the two brackets supplied with the **TOOL** from their plastic bag.
2. Remove the two M3x6 side screws, or use the two screws supplied with the bracket kit (for the following step).
3. Attach the pair of brackets.
To do so, fasten a bracket to each side of the **TOOL** using the M3x6 screws (according to the instructions provided with the bracket kit).

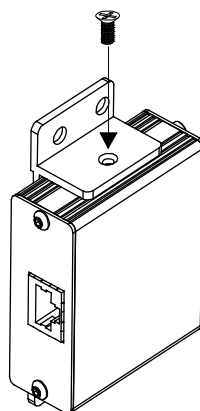

Figure 2: Installing the Brackets

4. Place the **TOOL** with the brackets over the external side of the **MTH-1** so that the four bracket holes will fit over four of the smaller holes on the **MTH-1**.
5. From the inner side of the **MTH-1**, insert the four M3x10 screws through the four holes of the **MTH-1** and brackets.

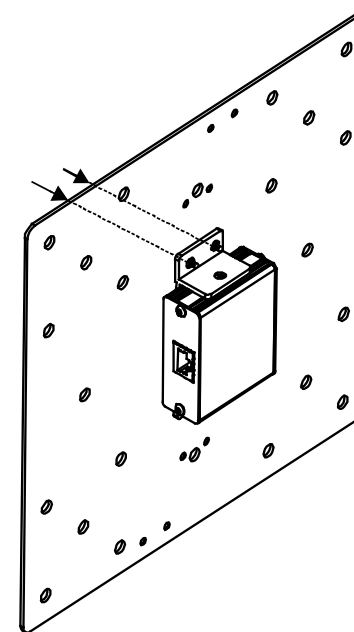

Figure 3: Attaching the TOOL to MTH-1

6. Place a spring washer over each screw and tighten the brackets to the **MTH-1** using the four M3 nuts (one for each screw).

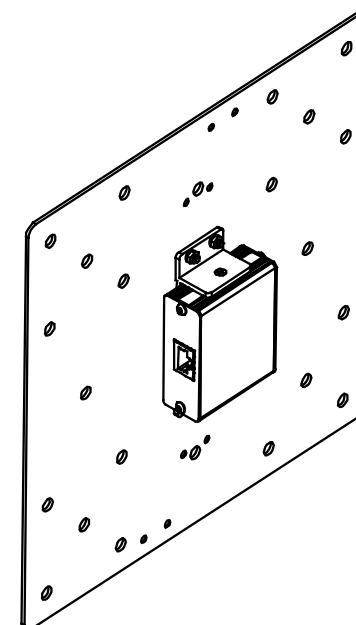

Figure 4: Fixing the TOOL to MTH-1



Note that the **MTH-1** is attached to the rear side of the display using the screws that were supplied with the display (either screwed into its rear side or in a separate bag).

7. Attach the **MTH-1** to the rear side of the display using the screws that were supplied by the display manufacturer.

The location of the screw-holes, as well as the number of screws used for each display may vary, depending on the manufacturer.

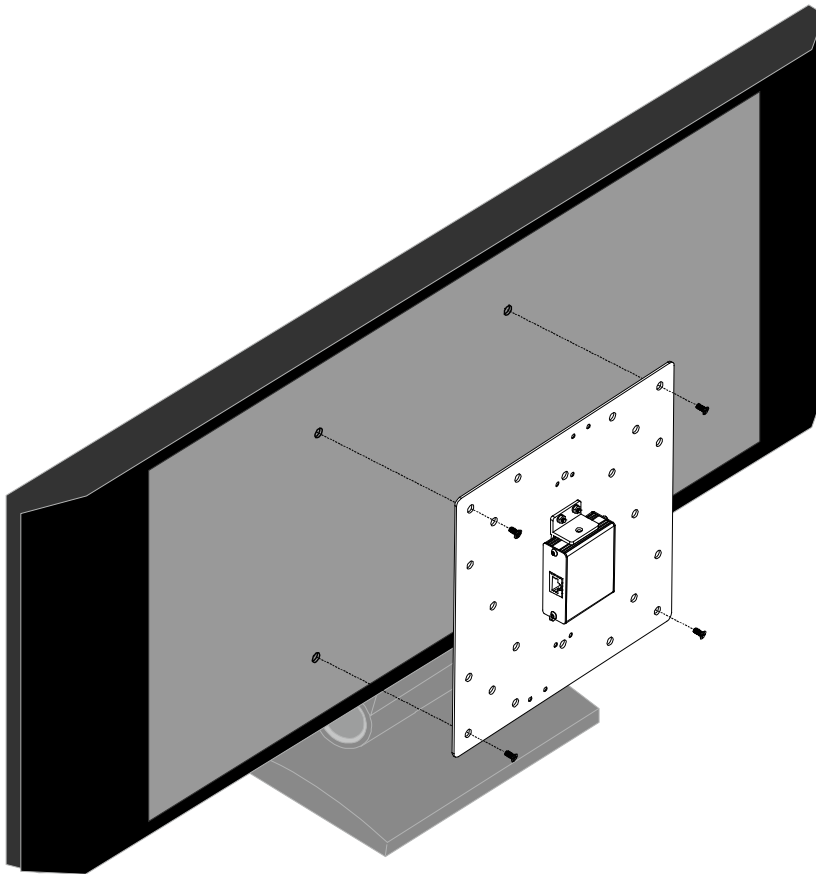

Figure 5: Attaching the MTH-1 to the Rear Side of the Display



KRAMER ELECTRONICS LTD.

Installation Instructions

MODEL:

MTH-1
VESA Adapter Plate

For the latest information on our products and a list of Kramer distributors, visit our Web site where updates to this user manual may be found.

We welcome your questions, comments, and feedback.

Web site: www.kramerelectronics.com

E-mail: info@kramerel.com



SAFETY WARNING

Disconnect the unit from the power supply before opening and servicing