

Kramer Electronics, Ltd.

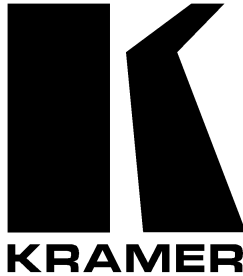

USER MANUAL

Models:

PIP-200xl, *Picture in Picture Inserter*

PIP-300, *Picture in Picture Inserter*

Contents

1	Introduction	1
2	Getting Started	1
2.1	Quick Start	1
3	Overview	3
4	Your Picture in Picture Inserter Machines	4
5	Installing on a Rack	8
6	Connecting the PIP-300 Picture in Picture Inserter	9
6.1	Connecting a PC	11
7	Configuring and Operating your PIP-300	12
7.1	Using the Menu	12
7.1.1	The Mode Submenu	14
7.1.2	The Video Settings Submenu	15
7.1.3	The Presets Submenu	15
7.1.4	The Labeling Submenu	16
7.2	Displaying the Layers in the PIP Mode	17
7.2.1	Selecting a Different Channel as the Background	17
8	Firmware Upgrade	18
8.1	Downloading from the Internet	18
8.2	Connecting the PC to the RS-232 Port	18
8.3	Upgrading Firmware	18
9	Technical Specifications	20
10	Communication Protocol	21

Figures

Figure 1:	PIP-200xl Picture in Picture Inserter	5
Figure 2:	PIP-300 Picture in Picture Inserter	6
Figure 3:	Connecting the PIP-300 Picture in Picture Inserter	10
Figure 4:	Connecting a PC without using a Null-modem Adapter	11
Figure 5:	The PIP-300 Menu Guide	13
Figure 6:	PIP Mode	14
Figure 7:	Goal Screen	19
Figure 8:	System Status Screen	19

Tables

Table 1: Front Panel Picture in Picture Inserter Features	7
Table 2: Rear Panel Picture in Picture Inserter Features	7
Table 3: The PIP-300 Main Menu Items	12
Table 4: The MODE Submenu Features	14
Table 5: PIP Sizing and Positioning Features	14
Table 6: Recommended PIP sizes	15
Table 7: Video Settings Submenu Features	15
Table 8: Presets Submenu Features	15
Table 9: Technical Specifications of the PIP-200xl and PIP-300 Picture in Picture Inserter	20
Table 10: Protocol Definitions	21
Table 11: Instruction Codes for the Communication Protocol	22

1 Introduction

Welcome to Kramer Electronics (since 1981): a world of unique, creative and affordable solutions to the infinite range of problems that confront the video, audio and presentation professional on a daily basis. In recent years, we have redesigned and upgraded most of our line, making the best even better! Our 500-plus different models now appear in 8 Groups¹, which are clearly defined by function.

Congratulations on purchasing your Kramer **PIP-200xl** *Picture in Picture Inserter* and/or **PIP-300** *Picture in Picture Inserter*, which are ideal for:

- Video production studios for source monitoring
- Teleconferencing using one screen
- Satellite, TV, home theater multi-channel monitoring
- Security applications

The package includes the following items:

- **PIP-200xl** or **PIP-300**
- Power cord and Null-modem adapter (for control via RS-232)
- This user manual²

2 Getting Started

We recommend that you:

- Unpack the equipment carefully and save the original box and packaging materials for possible future shipment
- Review the contents of this user manual
- Use Kramer high performance high resolution cables³

2.1 Quick Start

This **PIP-300** quick start chart summarizes the basic setup and operation steps⁴.

1 GROUP 1: Distribution Amplifiers; GROUP 2: Video and Audio Switchers, Matrix Switchers and Controllers; GROUP 3: Video, Audio, VGA/XGA Processors; GROUP 4: Interfaces and Sync Processors; GROUP 5: Twisted Pair Interfaces; GROUP 6: Accessories and Rack Adapters; GROUP 7: Scan Converters and Sealers; and GROUP 8: Cables and Connectors

2 Download up-to-date Kramer user manuals from our Web site at <http://www.kramerelectronics.com>

3 The complete list of Kramer cables is on our Web site at <http://www.kramerelectronics.com>

4 This quick start also applies for the PIP-200xl which has two sets of inputs instead of three

Step 1: Mount the machine - see section 5

Mount the machine in a rack or stick the 4 rubber feet to the underside

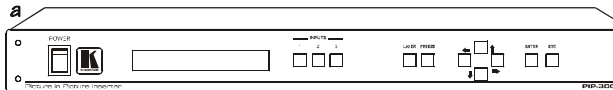

Step 2: Connect the inputs and outputs - see section 6

Connect the inputs

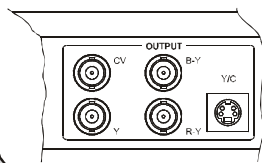
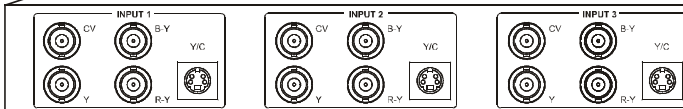

Connect the outputs

Step 3: Connect the control port - see section 6.1

Connect an RS-232 optional Control Port

Step 4: Turn the power ON

Step 5: Operate the machine - see section 7

- Select an INPUT
- Access the PIP sizing and positioning menu directly
- FREEZE the output image



Enter the menu via the front panel buttons:

- Use Navigation buttons
- ENTER the main menu, move to next level and confirm an action
- ESC from the menu, move to previous level and stop a command
- Freeze the output image

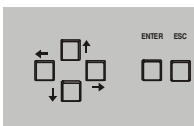

Menu appears on both the LCD display and the OSD

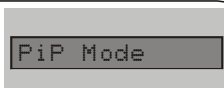

MENU Items

- **MODE:** SINGLE, PIP
- **OSD:** ON, OFF
- **BORDER:** ON, OFF, COLOUR (BLACK, WHITE)
- **VIDEO SETTINGS:** CONTRAST, SATURATION, BRIGHTNESS
- **INPUT SELECT:** COMPOSITE, S-VIDEO, COMPONENT
- **OUTPUT STANDARD:** NTSC, PAL
- **PRESETS:** STORE, RECALL, FACTORY DEFAULT
- **LABELING:** EDIT LABEL, LABEL ON, LABEL OFF

3 Overview

The high performance **PIP-200xl/PIP-300** is a picture-in-picture inserter for composite video, s-Video (Y/C) and component video (YUV¹).

The **PIP-300** and **PIP-200xl** feature:

- A multi standard picture-in-picture video inserter designed to accept three² video sources and display them all on the same screen simultaneously in two layers
- Three² sets of composite video, s-Video and component video inputs, and a composite video, s-Video and component video output
- Non-volatile memory that retains the last setting, after switching the power off and then on again³

Using the **PIP-200xl** or the **PIP-300** you can do the following:

- Position sources on the screen as desired and select their size from a list
- Put a text label in each inserted picture
- Put a border around each inserted picture
- Utilize sources of different formats and standards⁴

In addition, the **PIP-200xl/PIP-300**:

- Includes 10-bit video A/D and D/A converters throughout the unit, to ensure the highest quality video
- Is controllable via the front panel buttons and the user-friendly OSD and LCD, as well as via RS-232
- Is dependable, rugged, and fits in one vertical space of a standard 19" rack

To achieve the best performance:

- Connect only good quality connection cables, thus avoiding interference, deterioration in signal quality due to poor matching, and elevated noise-levels (often associated with low quality cables)
- Avoid interference from neighboring electrical appliances and position your Kramer **PIP-200xl/PIP-300** away from moisture, excessive sunlight and dust

1 Y, B-Y, R-Y (sometimes called Y, Pb/Cb, Pr/Cr)

2 Two for the PIP-200xl

3 Provided that the last setting was valid for at least 30 seconds before switching the machine OFF

4 For example, a PAL s-Video input could be inserted into a composite video NTSC source, and outputted to composite video, s-Video and component video formats

4 Your Picture in Picture Inserter Machines

This section defines each of the Picture-in-Picture Inserter machines:

- Figure 1 illustrates the **PIP-200xl** *Picture in Picture Inserter*
- Figure 2 illustrates the **PIP-300** *Picture in Picture Inserter*

Table 1 and Table 2 define the *Picture in Picture Inserter* machines.

Your Picture in Picture Inserter Machines

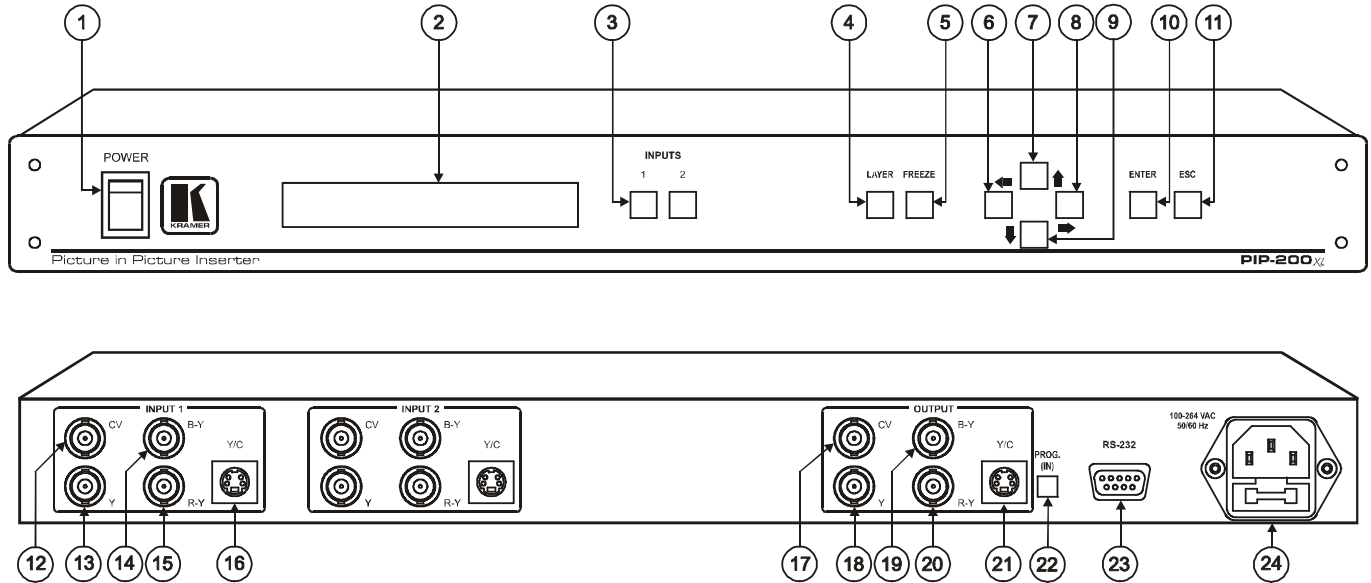

Figure 1: PIP-200xl Picture in Picture Inserter

Your Picture in Picture Inserter Machines

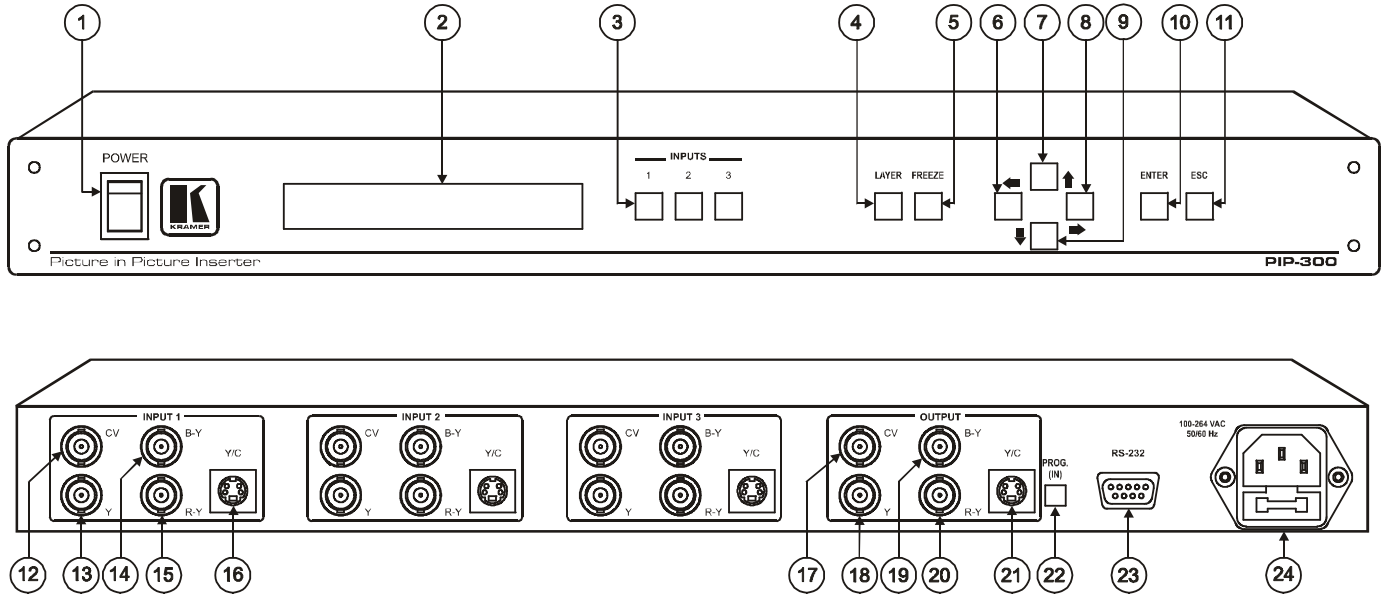

Figure 2: PIP-300 Picture in Picture Inserter

Table 1: Front Panel Picture in Picture Inserter Features

#	Feature	Function
1	POWER Switch	Illuminated switch for turning the unit ON or OFF
2	LCD Display	Displays data including the operation mode and the menu ¹ (2 lines at a time)
3	INPUTS ² Buttons	In the SINGLE mode: select the input to switch to the output In the PIP mode: select the input to appear in front Select an input for positioning and sizing
4	LAYER Button	When in the PIP mode, press to access the PIP Sizing and Position menu directly
5	FREEZE Button ³	Press to freeze/unfreeze the output video image
6	Navigation Buttons	← Moves the selected image to the left in the PIP mode ⁴ Moves to the previous character in the Labeling menu ⁵
7		↑ Moves the selected image upwards in the PIP mode ⁴ Moves up one step (in the same level) in the OSD screen Increases the range by one step in the OSD screen Use to change the selected character in the Labeling menu ⁵
8		→ Moves the selected image to the right in the PIP mode ⁴ Moves to the next character in the Labeling menu ⁵
9		↓ Moves the selected image downwards in the PIP mode ⁴ Moves down one step (in the same level) in the OSD screen Decreases the range by one step in the OSD screen Use to change the selected character in the Labeling menu ⁵
10	ENTER Button	Displays the main menu; moves to the next level; confirms a command
11	ESC Button	Exits the OSD Menu; reverts to the previous level; stops the execution of a command

Table 2: Rear Panel Picture in Picture Inserter Features

#	Feature	Function
12	INPUT ⁶	CV BNC Connector
13		Y BNC Connector
14		B-Y BNC Connector
15		R-Y BNC Connector
16	Y/C 4p Connector	Connects to the s-Video source
17	CV BNC Connector	Connects to the composite video acceptor
18	OUTPUT	Y BNC Connector
19		B-Y BNC Connector
20		R-Y BNC Connector
21		Y/C 4p Connector
22	PROG. (IN)	Push in to upgrade to the latest Kramer firmware (see section 8)
23	RS-232 Port	Connects to the PC or other serial controller
24	Power Connector with FUSE	AC connector enabling power supply to the unit

1 See Figure 5

2 PIP-200x1 has two input buttons and the PIP-300 has three input buttons

3 Illuminates when the image is frozen

4 See section 7.1.1.1

5 See section 7.1.4

6 The PIP-200x1 has 2 sets of inputs; the PIP-300 has 3 sets of inputs. Each set includes CV; Y, B-Y, R-Y; and Y/C

7 For component video, connect all 3 connectors: Y, B-Y, R-Y (also known as Y, Pb/Cb, Pr/Cr or YUV)

5 Installing on a Rack

This section describes what to do before installing on a rack and how to rack mount.

Before Installing on a Rack

Before installing on a rack, be sure that the environment is within the recommended range:	
Operating temperature range	+5 to +45 Deg. Centigrade
Operating humidity range	5 to 65% RHL, non-condensing
Storage temperature range	-20 to +70 Deg. Centigrade
Storage humidity range	5 to 95% RHL, non-condensing



CAUTION!!

When installing on a 19" rack, avoid hazards by taking care that:

- 1 It is located within the recommended environmental conditions, as the operating ambient temperature of a closed or multi unit rack assembly may exceed the room ambient temperature.
- 2 Once rack mounted, enough air will still flow around the machine.
- 3 The machine is placed straight in the correct horizontal position.
- 4 You do not overload the circuit(s). When connecting the machine to the supply circuit, overloading the circuits might have a detrimental effect on overcurrent protection and supply wiring. Refer to the appropriate nameplate ratings for information. For example, for fuse replacement, see the value printed on the product label.
- 5 The machine is earthed (grounded) in a reliable way and is connected only to an electricity socket with grounding. Pay particular attention to supply connections other than direct connections to the branch circuit (for example, the use of power strips), and that you use only the power cord that is supplied with the machine.

How to Rack Mount

To rack-mount a machine:

- 1 Attach both ear brackets to the machine. To do so, remove the screws from each side of the machine (3 on each side), and replace those screws through the ear brackets.

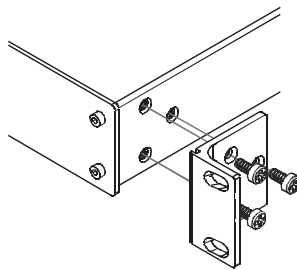

- 2 Place the ears of the machine against the rack rails, and insert the proper screws (not provided) through each of the four holes in the rack ears.

Note that:

- In some models, the front panel may feature built-in rack ears
- Detachable rack ears can be removed for desktop use
- Always mount the machine in the rack before you attach any cables or connect the machine to the power
- If you are using a Kramer rack adapter kit (for a machine that is not 19"), see the Rack Adapters user manual for installation instructions (you can download it at: <http://www.kramerelectronics.com>)

6 Connecting the PIP-300 Picture in Picture Inserter

To connect your **PIP-300**¹, as the example in Figure 3 illustrates, do the following²:

1. On the INPUT 1 set³ connect⁴:
 - An s-Video source to the Y/C INPUT 4p connector (for example, an s-Video player 1)
 - A component video source to the Y, B-Y, and R-Y INPUT BNC connectors (for example, a BETACAM video player 1)
2. On the INPUT 2 set⁴ connect a composite video source to the CV INPUT BNC connector (for example, a composite video player 2)
3. On the INPUT 3 set⁴ connect a composite video source to the CV INPUT BNC connector (for example, a composite video player 3)
4. Connect the OUTPUT connectors⁵, as follows:
 - The CV OUTPUT BNC connector to the composite video acceptor (for example, a composite video display)
 - The Y/C OUTPUT 4p connector to the s-Video acceptor (for example, an s-Video display)
 - The Y, B-Y, and R-Y OUTPUT BNC connectors to the component video acceptor (for example, a component video projector)
5. Connect a PC or other controller, if required (see section 6.1).
6. Connect the power cord⁶ (not illustrated in Figure 3).

1 From this section on, all the information is relevant to both the PIP-200xl and the PIP-300 machines, unless noted otherwise

2 Switch OFF the power on each device before connecting it to your PIP-300. After connecting your PIP-300, switch ON its power and then switch on the power on each device

3 PIP-200xl has two sets of inputs, the PIP-300 has three sets of inputs

4 You do not have to connect all the inputs in each set

5 If only one output is required, connect that output to the PIP-300, and leave the other outputs unconnected

6 We recommend that you use only the power cord that is supplied with this machine

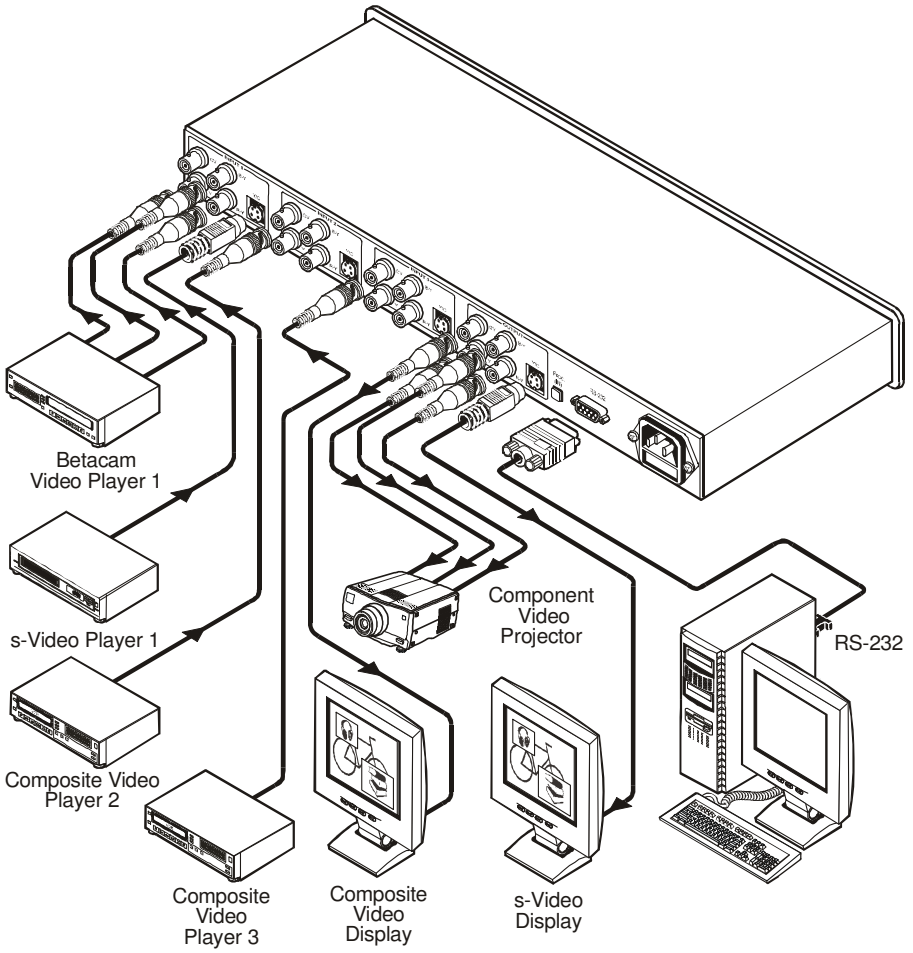

Figure 3: Connecting the PIP-300 Picture in Picture Inserter

6.1 Connecting a PC

To connect a PC to the **PIP-300** unit, using the Null-modem adapter provided with the machine (recommended):

- Connect the RS-232 DB9 rear panel port on the **PIP-300** unit to the Null-modem adapter and connect the Null-modem adapter with a 9-wire flat cable to the RS-232 DB9 port on your PC

To connect a PC to the **PIP-300** unit, without using a Null-modem adapter:

- Connect the RS-232 DB9 port on your PC to the RS-232 DB9 rear panel port on the **PIP-300** unit, as Figure 4 illustrates

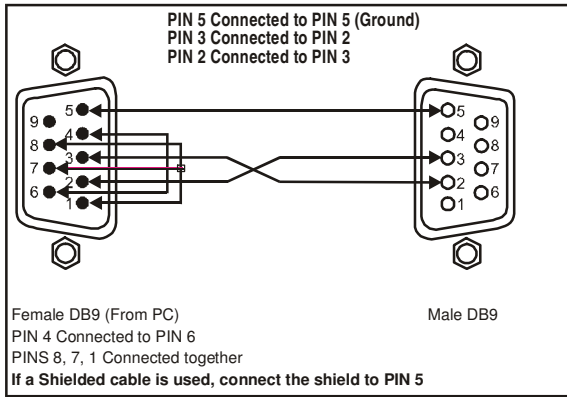

Figure 4: Connecting a PC without using a Null-modem Adapter

7 Configuring and Operating your PIP-300

You can configure and operate your **PIP-300** via:

- The front panel buttons, and/or
- RS-232 serial commands transmitted by a touch screen system, PC, or other serial controller

7.1 Using the Menu

Use the front panel buttons to activate the menu. The menu is displayed¹ on the LCD display² and is also superimposed on the screen^{2,3}.

To use the **PIP-300** menu, press the:

- ENTER button to display the menu and accept changes
- ESC button to move to the previous menu level
- ↑, ↓ arrow buttons to select the menu items, size and position the input display, adjust the numerical rates, and edit the text labeling
- ←, → arrow buttons to position the input display and to edit the text labeling

An asterisk in brackets indicates the current status on screen. For example, if the current OUTPUT SETTING is PAL, the OSD will show the asterisk in brackets alongside PAL: “PAL (*)”.

Table 3 defines the main menu items and Figure 5 illustrates the **PIP-300** menu guide:

Table 3: The PIP-300 Main Menu Items

Menu Item	Function
MODE	Select the SINGLE or the PIP mode, see section 7.1.1
OSD	Activates/deactivates the OSD menu ⁴
BORDER	Select a border around the image (applies to all channels) and select the border COLOUR (WHITE or BLACK)
VIDEO SETTINGS	Adjust the CONTRAST, SATURATION and BRIGHTNESS (see section 7.1.2)
INPUT SELECT	Select between: COMPOSITE video, S-VIDEO or COMPONENT video, per input channel
OUTPUT STANDARD	Select between NTSC and PAL
PRESETS	Store and recall PRESETS (1 and 2), or use FACTORY DEFAULT ⁵ settings, see section 7.1.3
LABELING	Display, remove and edit the text label for the input channel, see section 7.1.4

1 The menu always displays only two lines at a time on the LCD display. Use the up/down arrow buttons to scroll up/down the menu

2 Upon powering up, the LCD briefly displays the machine's name, and the OSD displays the firmware version

3 The menu times out after a minute, both on the LCD display and on the OSD

4 Menu still appears on the LCD display even when deactivated in the OSD

5 The machine is set to Single mode, Channel 1, default video settings and default labeling

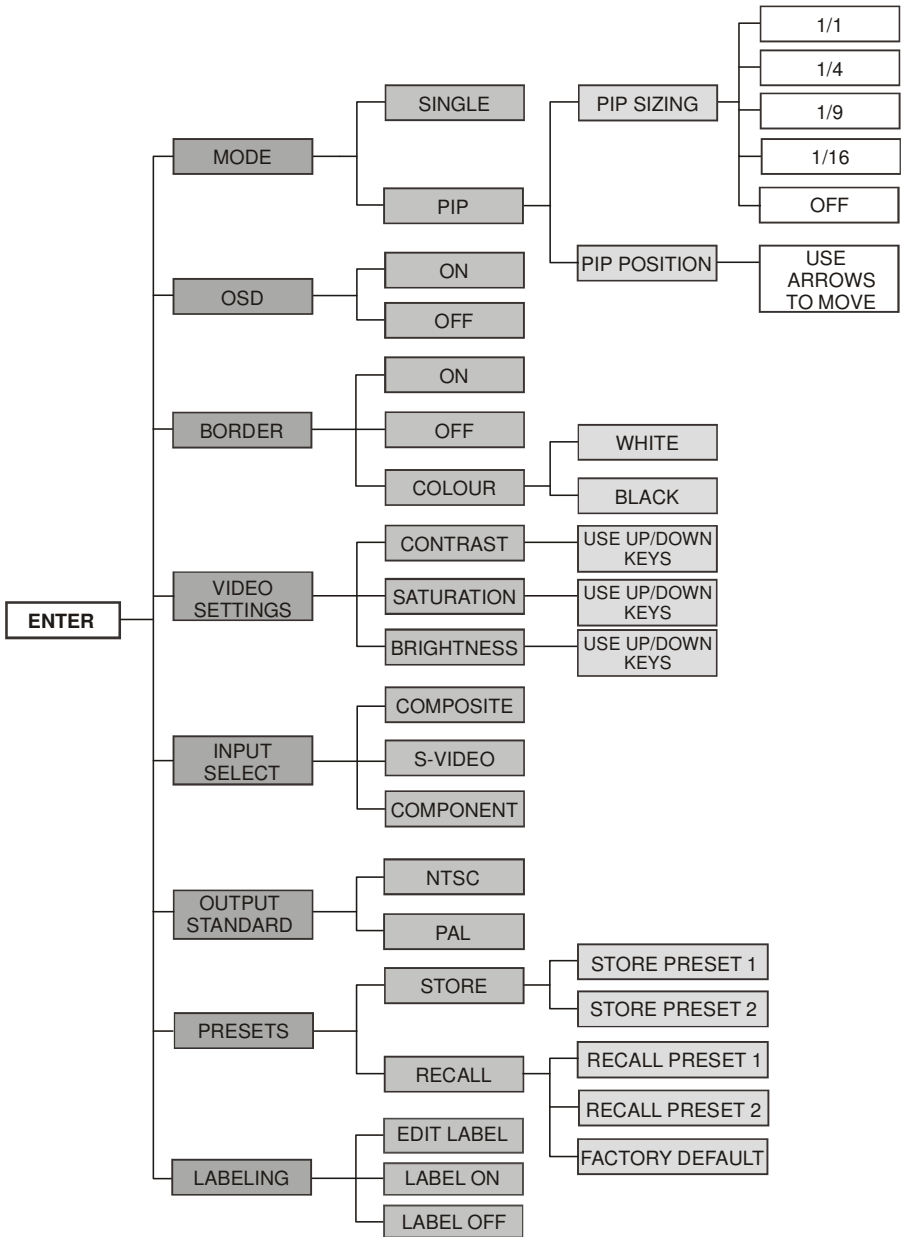

Figure 5: The PIP-300 Menu Guide

7.1.1 The Mode Submenu

Table 4 defines the MODE submenu features:

Table 4: The MODE Submenu Features

Mode	Function
SINGLE	Displays one input channel at a time on the screen (full screen display). The LCD display shows the display mode and the selected channel, for example, "Single Mode – Channel 2"
PIP	Displays all 3 input channels ¹ on the screen. Once the PIP mode is selected, the PIP SIZING and PIP POSITION commands appear, as illustrated in Figure 6 (see section 7.1.1.1). The LCD display shows "PIP Mode"

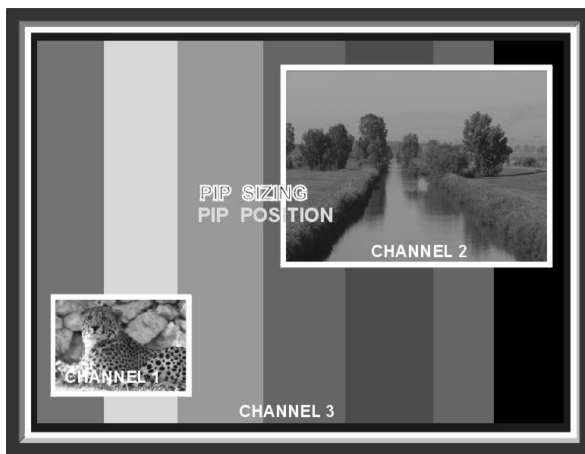

Figure 6: PIP Mode

When selecting the SINGLE mode following the PIP mode, the input channel (that is currently selected) is displayed.

7.1.1.1 PIP Sizing and Position

To size and/or position a PIP image (as Table 5 defines):

1. Press the desired input channel button (1 to 3)¹. The input button blinks.
2. Select either PIP SIZING or PIP POSITION (using the up/down arrow buttons) and press ENTER.

Table 5: PIP Sizing and Positioning Features

Menu Item	Function
PIP SIZING	Use the ↑ , ↓ arrow buttons to select between 1/1, 1/4, 1/9 and 1/16 display sizes or OFF ²
PIP POSITION	Use the ↑ , ↓ , ← and → arrow buttons to position the selected channel vertically and horizontally

¹ PIP-200x1 has two input channels

² If OFF is selected, the selected input channel will not be displayed on the screen

When using one of the inputs as a full-sized background (PIP size 1/1), it is recommended to limit the sizes of the other PIP windows according to Table 6. Combinations having window sizes larger than recommended, may result in intermittent interruptions in the picture.

Note that these restrictions only apply when a 1:1 sized picture is used. When all the pictures are reduced in size, there are no restrictions

Table 6: Recommended PIP sizes

1 PIP	2 PIPs
1/4	1/4 + 1/9
1/9	1/4 + 1/16
1/16	1/9 + 1/9
	1/9 + 1/16
	1/16 + 1/16

7.1.2 The Video Settings Submenu

Table 7 defines the video settings:

Table 7: Video Settings Submenu Features

Menu Item	Function	Range	Default
CONTRAST	Use the up/down arrow buttons to set the contrast	0 to 100	55
SATURATION	Use the up/down arrow buttons to set the saturation	0 to 100	51
BRIGHTNESS	Use the up/down arrow buttons to set the brightness	0 to 100	33

Video settings apply to all the input channels.

7.1.3 The Presets Submenu

Table 8 defines the Presets submenu:

Table 8: Presets Submenu Features

Menu Item	Function
STORE ¹	Select PRESET 1 and PRESET 2 to store the mode settings (channel number when in the SINGLE mode, size and positioning in PIP mode), and the video settings (contrast, saturation and brightness)
RECALL	Recall PRESET 1 and PRESET 2 settings, or set to FACTORY DEFAULT ²

¹ When storing a new setting, wait 10 seconds for the setup to be saved

² The machine is set to Single mode, Channel 1, default video settings and default labeling

7.1.4 The Labeling Submenu

The labeling submenu lets you display labels over the input pictures, remove them from the display or edit them. To turn labels on or off select the LABEL ON or LABEL OFF items in the LABELING menu respectively.

The input pictures are labeled¹ Channel 1 to Channel 3 by default². You can edit the text labels for each channel by using the labeling submenu:

- Press ENTER on the LABELING submenu and choose the EDIT LABEL command. The selected channel name appears with its first letter blinking
- Use the ↑ and ↓ buttons to select the first desired letter³
- Use the → button to continue to the next letter
- Use the ← button to return to the previous letter
- Use the ENTER button to accept changes

For example, to change the labeling from CHANNEL 2 to SAT 3, do the following:

1. Press the INPUT 2 button, and then press the ENTER button.
2. Select LABELING from the menu and choose the EDIT LABEL menu item.
The CHANNEL 2 label appears, and the first character is blinking.
3. Press the ↑ button 16 times to change the letter C to S, and then press the → button to continue to the second letter (H).
4. Press the ↓ button 7 times to change the letter H to A, and then press the → button to continue to the third letter.
5. Press the ↑ button 19 times to change the letter A to T, and then press the → button to continue to the next letter.
6. Press the ↓ button 14 times to change the letter N to a blank space, and then press the → button to continue to the next letter.
7. Press the ↑ button 15 times to change the letter N to 3, and then press the → button to continue to the next letter.
8. Press the ↑ or ↓ buttons to change the remaining characters to blank spaces.
9. Press ENTER to accept changes.

¹ In some versions, the labeling does not appear on the 1:1 sized image (in the PIP mode) or when the PIPs overlap

² For PIP-200x1, Channel 1 and Channel 2

³ Characters cycle between a and z, and between 1 and 0 and space



7.2 Displaying the Layers in the PIP Mode

To display a picture in picture on the screen, do the following:

1. Select an input.
2. Select the PIP mode.
3. Size and position each layer as desired¹.
4. Press an INPUT button to bring forward that input on the screen.

7.2.1 Selecting a Different Channel as the Background

In the following example, Channel 2 replaces Channel 3 as the background.

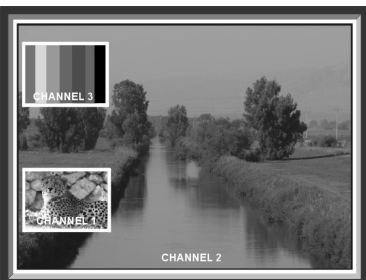
<p>A</p> <p>The current screen shows:</p> <ul style="list-style-type: none"> • Channel 3 in the background (PIP SIZING: 1:1) • Channel 1 in front (PIP SIZING: 1:16) • Channel 2 in front (PIP SIZING: 1:4) 	
<p>B Select Channel 2 and size it to 1:1 as follows:</p> <p>A. Press INPUT 2</p> <p>B. Press the LAYER button (or follow steps 1 to 3)</p> <ol style="list-style-type: none"> 1. Press ENTER 2. Press ENTER again to select MODE 3. Scroll down to PIP and press ENTER <p>C. Press ENTER to select PIP SIZING</p> <p>D. Press ENTER to size to 1:1</p> <p>The current screen shows:</p> <ul style="list-style-type: none"> • Channel 2 in front (PIP SIZING: 1:1) • Channels 1, and 3 are behind, unseen 	
<p>C</p> <p>Press INPUT button 1, or 3</p> <p>The current screen shows:</p> <ul style="list-style-type: none"> • Channel 2 in the background • Channels 1 and 3 in front <p>Size and position channels 1 and 3 as desired</p>	

¹ Only one channel can be sized to 1:1, the others should be smaller in size or OFF (see Table 6)

8 Firmware Upgrade

The **PIP-300** firmware is located in FLASH memory, which lets you upgrade to the latest Kramer firmware version in minutes! The process involves:

- Downloading from the Internet (see section 8.1)
- Connecting the PC to the RS-232 port (see section 8.2)
- Upgrading firmware (see section 8.3)

8.1 Downloading from the Internet

You can download the up-to-date file from the Internet. To do so:

1. Go to our Web site at <http://www.kramerelectronics.com> and download the relevant zip file from the Technical Support section.
2. Extract this file to a folder (for example, C:\Program Files\KramerFlash).
3. Create a shortcut on your desktop to the EXE file, and install the GOAL TENDER programmer software, following the on-screen installation instructions.

8.2 Connecting the PC to the RS-232 Port

Before installing the latest Kramer firmware version on a **PIP-300** unit, do the following:

1. Connect the RS-232 DB9 rear panel port on the **PIP-300** unit to the RS-232 DB9 COM port on your PC, via a **straight pin-to-pin cable**¹ (no null-modem adapter is used in this case!).
2. Push in the PROG. (IN) button.
3. Connect the power to the **PIP-300** unit and switch it ON.

8.3 Upgrading Firmware

Follow these steps to upgrade the firmware:

1. Double click the 1000-ISPV2 icon on the desktop.
The software immediately searches for communication between the PC and the **PIP-300**, and the GOAL screen appears as follows:

¹ For firmware upgrade via the RS-232 port, no Null-modem connection is required. The Null modem (supplied) is used for control via RS-232, not for upgrading

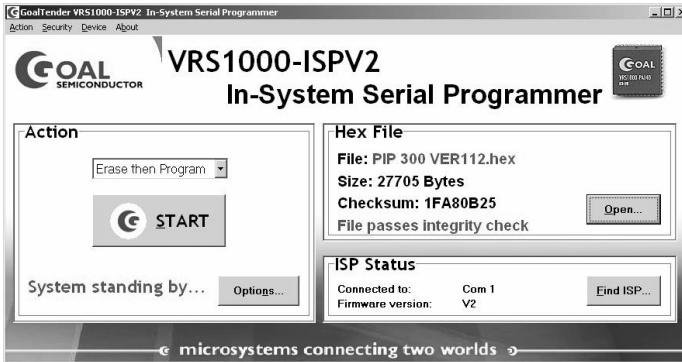

Figure 7: Goal Screen

2. Click the **Open...** button to select the new firmware hex file¹.
3. Click the **Options...** button, select the **Inverted**² check box in the **Reset Polarity** area and Click **OK**.
4. In the **Action** area, select **Erase then Program**.
5. Click the **START** button.

The software erases and then programs flash memory.

Upon Completion of the operation, the System Status Window displays: “Erase and program completed successfully” (see Figure 8).



Figure 8: System Status Screen

6. Exit the programmer software.
7. Disconnect the power on the **PIP-300**.
8. Release the PROG. (IN) button.
9. Connect the power on the **PIP-300**.

¹ Located in the C:\Program Files\KramerFlash folder

² In some models you need to select the Normal check box

9 Technical Specifications

Table 9 includes the technical specifications¹:

Table 9: Technical Specifications² of the PIP-200xl and PIP-300 Picture in Picture Inserter

	PIP-200xl	PIP-300
INPUTS:	2 sets, each with: 1 composite video 1Vpp/75Ω on a BNC connector 1 s-Video 1Vpp, 0.3Vpp/75Ω on a 4p connector 1 component video 1Vpp, 0.7Vpp, 0.7Vpp/75Ω on BNC connectors	3 sets, each with: 1 composite video 1Vpp/75Ω on a BNC connector 1 s-Video 1Vpp, 0.3Vpp/75Ω on a 4p connector 1 component video 1Vpp, 0.7Vpp, 0.7Vpp/75Ω on BNC connectors
OUTPUTS:	1 component video 1Vpp, 0.7Vpp, 0.7Vpp / 75Ω on BNC connectors 1 s-Video 1Vpp, 0.3Vpp / 75Ω on a 4p connector 1 composite video 1Vpp / 75Ω on a BNC connector	
DIGITAL RESOLUTION:	10 bit	
VIDEO BANDWIDTH:	5.5MHz	
K-FACTOR:	0.9%	
S/N RATIO:	66dB	
DIFFERENTIAL PHASE:	1%	
DIFFERENTIAL GAIN:	1%	
LUMA NON-LINEARITY:	1%	
CHROMA / LUMA DELAY:	< 15ns	
YC SEPARATION:	Adaptive 4-line digital comb filters	
MEMORY:	Non-volatile memory for storage of 2 setups	
CONTROL:	Front-panel and RS-232: PIP size, position and layer priority; video ProcAmp functions; video zoom; freeze	
POWER SOURCE:	Universal, 90-240VAC, 50/60Hz, 38VA	
DIMENSIONS:	19" (W), 9.3" (D), 1U (H) rack mountable	
WEIGHT:	2.8kg (6.2lbs) approx.	
ACCESSORIES:	Power cord, null modem adapter	

¹ Measurements relate to composite video, unless otherwise stated

² Specifications are subject to change without notice

10 Communication Protocol¹

This RS-232/RS-485 communication protocol uses four bytes of information as defined below. A null-modem connection (pin 2 and pin 3 crossed; pins 5 connected together) is used to link the PIP unit to the controller unit (for example, PC). The data rate is 9600 baud, with no parity, 8 data bits and 1 stop bit.

When switching (for example, instruction codes 1 and 2), the INPUT (7 bits) is set as the input number, which is to be switched. Similarly, if switching is done via the machine's front-panel, then these bits are set with the INPUT NUMBER, which was switched. For other operations, these bits are defined according to the table.

Table 10: Protocol Definitions

MSB				LSB			
7	6	5	4	3	2	1	0
		DESTINATION	INSTRUCTION				
0	D	INST ₅	INST ₄	INST ₃	INST ₂	INST ₁	INST ₀
1st byte							
		REQUEST	INPUT				
1	RQ	BYTE2 ₅	BYTE2 ₄	BYTE2 ₃	BYTE2 ₂	BYTE2 ₁	BYTE2 ₀
2nd byte							
		BYTE3					
1	BYTE3 ₆	BYTE3 ₅	BYTE3 ₄	BYTE3 ₃	BYTE3 ₂	BYTE3 ₁	BYTE3 ₀
3rd byte							
		LAST					
1	BYTE3 ₇	0	0	1	0	0	0
4th byte							

1st BYTE: Bit 7 – Defined as 0
 Bit 6 – “DESTINATION BIT”: 0 – information is sent from the PC to the PIP
 1 – information is sent from the PIP to the PC
 Bit 5 to Bit 0 (INST₅,...,INST₀) – “INSTRUCTION” (6 bits)

The function that is to be performed is defined by the INSTRUCTION code (6 bits). Similarly, if a function is performed via the machine's keyboard, then the machine sends the appropriate INSTRUCTION code. The instruction codes are defined according to the table below.

2nd BYTE: Bit 7 – Defined as 1
 Bit 6 – “REQUEST BIT”: 0 – normal operation
 1 – requests the PIP to send current data to the PC
 Bit 5 to Bit 0 (BYTE2₅,...,BYTE2₀) – 2nd byte (6 bits)

If the request bit is set, then the PIP will reply by sending the data related to this instruction to the PC. If not set, then the PIP performs the instruction and replies by returning the same 4 bytes (except for the DESTINATION BIT).

3rd BYTE: Bit 7 – Defined as 1
 Bit 6 to Bit 0 (BYTE3₆,...,BYTE3₀) – 7 bits of BYTE3 (BYTE3₇ is in LAST byte)

4th BYTE: Defined as 0x88 (ie. 88hex) for BYTE3₇ = 0; or 0xc8 for BYTE3₇ = 1

Table 11: Instruction Codes for the Communication Protocol

INSTRUCTION		DEFINITION FOR SPECIFIC INSTRUCTION	
# (Hex)	Description	BYTE2	BYTE3
0x00	Reset	0	0
0x01	Active input select	1 to 5 – select input number	0
0x02	Mode select	0	0 for single mode (non-PIP) 1 for PIP mode 2 for QUAD
0x03	Store	1 to 0x02 – address for storing	0 to store 1 to erase
0x04	Recall	0 to 0x02 – address to retrieve	0
0x09	Video input format	1 to 5 – input number	0 – CV 1 – Y/C 2 – YUV
0x0A	Request video input standard	1 to 5 – input number	1 – NTSC 2 – PAL (B, G, H, I) 3 – PAL-M 4 – PAL-N 5 – NTSC4.43 6 – SECAM
0x0B	Video output standard	0	1 – NTSC 2 – PAL (B, G, H, I) 3 – PAL-M 4 – PAL-N 5 – NTSC4.43
0x10	Error	0	0
0x11	Contrast	0	0 to 100
0x12	Saturation	0	0 to 100
0x13	Brightness	0	0 to 100
0x1a	PIP size	1 to 5 – input number	1 – 1:1 2 – 1/4 3 – 1/9 4 – 1/16
0x1b	PIP position: X	1 to 5 – input number	0 to maximum to the right
0x1c	PIP position: Y	1 to 5 – input number	0 to maximum to the bottom
0x1d	Border	0	0 – Off 1 – White border 2 – Black border
0x1e	Freeze	1 to 5 – input number	0 – Normal operation 1 – Frozen
0x21	Label: character 1	1 to 5 – input number	Hex value of ASCII character
0x22	Label: character 2	1 to 5 – input number	Hex value of ASCII character
0x23	Label: character 3	1 to 5 – input number	Hex value of ASCII character
0x24	Label: character 4	1 to 5 – input number	Hex value of ASCII character
0x25	Label: character 5	1 to 5 – input number	Hex value of ASCII character
0x26	Label: character 6	1 to 5 – input number	Hex value of ASCII character
0x27	Label: character 7	1 to 5 – input number	Hex value of ASCII character
0x28	Label: character 8	1 to 5 – input number	Hex value of ASCII character
0x29	Label: character 9	1 to 5 – input number	Hex value of ASCII character
0x31	OSD	0	0 – OSD off 1 – OSD on
0x39	Auto-save	0	0 – Auto-save off 1 – Auto-save on
0x3d	Identify machine	1	2 – for PIP-200 (reply) 3 – for PIP-300 (reply) 4 – for PIP-400 (reply) 5 – for PIP-500 (reply)
		3	Software version (reply)

DETAILS OF INSTRUCTION SET

Instruction 0x00: Reset

When machine is turned on, it sends a **Reset** code to the PC (0x40 0x80 0x80 0x88).

If this code is sent to the switchers with **Byte3** = 0, it will reset according to the present power-down settings. (See instruction #4 for resetting the PIP to its factory default state).

Instruction 0x01: Input select

Sending this instruction will select the input number that is specified in **Byte2**.

For example:

- To select input 2, send 0x01 0x82 0x80 0x88. The unit responds by sending 0x41 0x81 0x80 0x88

Instruction 0x02: Mode select

Sending this instruction with **Byte3** = 0 will set the unit to output a single picture; setting **Byte3** to any other value will set the unit to work in Picture-In-Picture (PIP) mode.

To request the operation mode, set the RQ bit. The unit responds by setting **Byte3** appropriately.

For example:

- To set for PIP mode, send 0x02 0x80 0x81 0x88.
- To find out the operation mode in this case, send 0x02 0xc0 0x80 0x88. The unit responds by sending 0x42 0x80 0x81 0x88.

Instruction 0x03: Store

Sending this instruction with **Byte3** = 0 will store the unit's current settings in non-volatile memory. **Byte2** selects the memory address (1 or 2). If **Byte3** = 1, then the memory's setting is cleared.

To inquire whether a setting is stored in a memory address, set the RQ bit. The unit responds by setting **Byte3** as 0 if data is saved, or 1 if not.

For example:

- To save to memory 2, send 0x03 0x82 0x80 0x88.
- To find out if data is stored in memory 2, send 0x03 0xc2 0x80 0x88. Since there *is* data stored, the unit responds by sending 0x43 0x80 0x80 0x88.
- To erase memory 2, send 0x03 0x82 0x81 0x88.

Instruction 0x04: Recall

Sending this instruction will recall the settings stored in non-volatile memory. **Byte2** selects the memory address (1 or 2). To recall the factory reset settings, select **byte2** = 0.

There is no inquire (RQ) for this instruction.

For example:

- To recall from memory 1, send 0x04 0x81 0x80 0x88.

Instruction 0x09: Video Input Format

Sending this instruction selects the video format (**Byte3**) for an input (**Byte2**).

To inquire which video format is selected on an input, set the RQ bit. The unit responds by setting **Byte3** appropriately.

For example:

- To set input 4 for Y/C, send 0x09 0x84 0x81 0x88.
- To find out the video format for input 4 in this case, send 0x09 0xc4 0x80 0x88. The unit responds by sending 0x49 0x84 0x81 0x88.

Instruction 0x0a: Request Video Input Standard

This "instruction" can only be used with the RQ bit set. It is used to inquire which video standard is detected on an input. The unit responds by setting **Byte3** appropriately.

For example:

- To inquire which standard is detected on input 3, send 0x0a 0xc3 0x80 0x88. If a PAL-B input is present, then the unit responds by sending 0x4a 0x83 0x81 0x88.

Instruction 0x0b: Video Output Standard

Sending this instruction selects the video output standard (**Byte3**).

NOTE: If the unit does not support the standard, then it will return an ERROR code (Instruction 0x10)

To request which video standard has been selected on the output, set the RQ bit. The unit responds by setting **Byte3** appropriately.

For example:

- To set the machine to output PAL, send 0x0b 0x80 0x81 0x88.
- To find out the video format for in this case, send 0x0b 0xc0 0x80 0x88. The unit responds by sending 0x4b 0x80 0x81 0x88.

Instruction 0x10: Error

This is the code returned by the machine if invalid data is received (it is not really an instruction).

For example:

- If the user sends 0x01 0x87 0x81 0x88 (ie. he tries to select input # 7 – which is an invalid input number), the unit will respond by sending 0x50 0x80 0x80 0x88.

Instruction 0x11: Contrast

Send this instruction to set the CONTRAST (**Byte3**) of an input (**Byte2**).

To request the CONTRAST value of an input, set the RQ bit. The unit responds by setting **Byte3** appropriately.

For example:

- To set the CONTRAST of input 2 to 0x7b, send 0x11 0x82 0xfb 0x88.
- To set the CONTRAST of input 2 to 0xac, send 0x11 0x82 0xac 0xc8 (MSB of BYTE3 is in LAST byte).
- To find out the CONTRAST setting of input 2, send 0x11 0xc2 0x80 0x88. The unit would respond by sending 0x51 0xc2 0xac 0xc8 in the latter case.

Instruction 0x12: Saturation

Send this instruction to set the SATURATON (**Byte3**) of an input (**Byte2**).

To request the SATURATION value of an input, set the RQ bit. The unit responds by setting **Byte3** appropriately.

For example:

- To set the SATURATION of input 3 to 0x04, send 0x12 0x83 0x84 0x88.
- To set the SATURATION of input 3 to 0xb6, send 0x12 0x83 0xb6 0xc8 (MSB of BYTE3 is in LAST byte).
- To find out the SATURATION setting of input 3, send 0x12 0xc3 0x80 0x88. The unit would respond by sending 0x52 0xc3 0xb6 0xc8 in the latter case.

Instruction 0x13: Brightness

Send this instruction to set the BRIGHTNESS (**Byte3**) of an input (**Byte2**).

To request the BRIGHTNESS value of an input, set the RQ bit. The unit responds by setting **Byte3** appropriately.

For example:

- To set the BRIGHTNESS of input 1 to 0x73, send 0x13 0x81 0xf3 0x88.
- To set the BRIGHTNESS of input 1 to 0xfe, send 0x13 0x81 0xfe 0xc8 (MSB of BYTE3 is in LAST byte).
- To find out the BRIGHTNESS setting of input 1, send 0x13 0xc1 0x80 0x88. The unit would respond by sending 0x53 0xc1 0xf3 0x88 in the former case.

Instruction 0x1a: PIP size

Sending this instruction selects the PIP size (**Byte3**) of an input (**Byte2**).

To inquire about the PIP size of one of the inputs, set the RQ bit. The unit responds by setting **Byte3** appropriately.

For example:

- To set the PIP size of input 2 to 1/9, send 0x1a 0x82 0x83 0x88.
- To find out the PIP size of input 2 in this case, send 0x1a 0xc2 0x80 0x88. The unit responds by sending 0x5a 0xc2 0x83 0x88.

Instruction 0x1b: PIP position: X

Sending this instruction positions the x co-ordinate (**Byte3**) of an input (**Byte2**).

To request the x co-ordinate of an input, set the RQ bit. The unit responds by setting **Byte3** appropriately.

For example:

- To set the x co-ordinate of input 2 at 0x57, send 0x1b 0x82 0xd7 0x88.
- To set the x co-ordinate of input 2 at 0x97, send 0x1b 0x82 0x87 0xc8.
- To find out the x co-ordinate for input 2, send 0x1b 0xc2 0x80 0x88. The unit would respond by sending 0x5b 0xc2 0xd7 0x88 in the former case, or by sending 0x5b 0xc2 0xd7 0xc8 in the latter case.

Instruction 0x1c: PIP position: Y

Sending this instruction positions the y co-ordinate (**Byte3**) of an input (**Byte2**).

To request the y co-ordinate of an input, set the RQ bit. The unit responds by setting **Byte3** appropriately.

For example:

- To set the y co-ordinate of input 2 at 0x14, send 0x1c 0x82 0x94 0x88.
- To set the y co-ordinate of input 2 at 0x94, send 0x1c 0x82 0x94 0xc8.
- To find out the y co-ordinate for input 2, send 0x1c 0xc2 0x80 0x88. The unit would respond by sending 0x5c 0xc2 0x94 0x88 in the former case, or by sending 0x5c 0xc2 0x94 0xc8 in the latter case.

Instruction 0x1d: Border

Send this instruction to select whether there is a BORDER around the PIPs, and to select the color of the BORDER. **Byte3** configures the selection.

To inquire about the BORDER, set the RQ bit. The unit responds by setting **Byte3** appropriately.

For example:

- To set a white border, send 0x1d 0x80 0x81 0x88.
- To find out about the border, send 0x1d 0xc0 0x80 0x88. In this case the unit would respond by sending 0x5d 0xc0 0x81 0x88.

Instruction 0x1e: Freeze

Send this instruction to FREEZE or UNFREEZE an input.

To inquire if an input is frozen, set the RQ bit. The unit responds by setting **Byte3** appropriately.

For example:

- To freeze input 3, send 0x1e 0x83 0x81 0x88.
- To find out whether input 3 is frozen, send 0x1e 0xc3 0x80 0x88. In this case the unit would respond by sending 0x5e 0xc3 0x81 0x88.

Instruction 0x21 to Instruction 0x29: Labeling

For these instructions, set **Byte2** with the input number and set **Byte3** is set with the hexadecimal value of the ASCII character. The character number is defined from right to left (when read), with the right-hand most character = character 1. Up to 9 characters are allowed in any label.

To request the character of a label, define **Byte2** as above, and set the RQ bit. The unit responds by setting **Byte3** appropriately.

For example:

- To label input 3 as "KRAMER", send the following data:
0x26 0x83 0xcb 0x88 ("K" defined to character 6)
0x25 0x83 0xd2 0x88 ("R" defined to character 5)
0x24 0x83 0xc1 0x88 ("A" defined to character 4)
0x23 0x83 0xcd 0x88 ("M" defined to character 3)
0x22 0x83 0xc5 0x88 ("E" defined to character 2)
0x21 0x83 0xd2 0x88 ("R" defined to character 1)
- To request character number 5 defined to input 3 in the example above (ASCII "R", ie. 0x52), send 0x25 0xc3 0x80 0x88. The unit responds by sending 0x65 0xc3 0xd2 0x88.

Instruction 0x31: OSD

Send this instruction to select whether or not to display the OSD (On-Screen-Display). Note that the front-panel LCD is independent of the OSD status.

To inquire if the OSD is on, set the RQ bit. The unit responds by setting **Byte3** appropriately.

For example:

- To turn on the OSD, send 0x31 0x80 0x81 0x88.
- To inquire about the OSD setting, send 0x31 0xc0 0x80 0x88. In this case the unit would respond by sending 0x71 0xc0 0x81 0x88.

Instruction 0x39: Auto-save

Send this instruction to select whether or not to recall the unit's last settings when cycling power.

To inquire if the auto-save option is on, set the RQ bit. The unit responds by setting **Byte3** appropriately.

For example:

- To turn on the auto-save option, send 0x39 0x80 0x81 0x88.
- To inquire about the auto-save setting, send 0x39 0xc0 0x80 0x88. In this case the unit would respond by sending 0x79 0xc0 0x81 0x88.

Instruction 0x3d: Identify machine

This instruction (inquiry) is used for machine identification. It can only be used with the RQ bit set. The user sends the inquiry with the **INSTRUCTION** and **Byte3** as defined above, and the unit answers with the appropriate value of **Byte3**.

For example:

- If 0x3d 0xc1 0x80 0x88 is sent to a PIP-300, it would reply by sending 0x7d 0xc1 0x83 0x88
- If 0x3d 0xc1 0x80 0x88 is sent to a PIP-400, it would reply by sending 0x7d 0xc1 0x84 0x88
- If 0x3d 0xc3 0x80 0x88 is sent to a unit with version number 6.3, it would reply by sending 0x7d 0xc6 0x83 0x88

LIMITED WARRANTY

Kramer Electronics (hereafter *Kramer*) warrants this product free from defects in material and workmanship under the following terms.

HOW LONG IS THE WARRANTY

Labor and parts are warranted for seven years from the date of the first customer purchase.

WHO IS PROTECTED?

Only the first purchase customer may enforce this warranty.

WHAT IS COVERED AND WHAT IS NOT COVERED

Except as below, this warranty covers all defects in material or workmanship in this product. The following are not covered by the warranty:

1. Any product which is not distributed by Kramer, or which is not purchased from an authorized Kramer dealer. If you are uncertain as to whether a dealer is authorized, please contact Kramer at one of the agents listed in the web site www.kramerelectronics.com.
2. Any product, on which the serial number has been defaced, modified or removed.
3. Damage, deterioration or malfunction resulting from:
 - i) Accident, misuse, abuse, neglect, fire, water, lightning or other acts of nature
 - ii) Product modification, or failure to follow instructions supplied with the product
 - iii) Repair or attempted repair by anyone not authorized by Kramer
 - iv) Any shipment of the product (claims must be presented to the carrier)
 - v) Removal or installation of the product
 - vi) Any other cause, which does not relate to a product defect
 - vii) Cartons, equipment enclosures, cables or accessories used in conjunction with the product

WHAT WE WILL PAY FOR AND WHAT WE WILL NOT PAY FOR

We will pay labor and material expenses for covered items. We will not pay for the following:

1. Removal or installations charges.
2. Costs of initial technical adjustments (set-up), including adjustment of user controls or programming. These costs are the responsibility of the Kramer dealer from whom the product was purchased.
3. Shipping charges.

HOW YOU CAN GET WARRANTY SERVICE

1. To obtain service on your product, you must take or ship it prepaid to any authorized Kramer service center.
2. Whenever warranty service is required, the original dated invoice (or a copy) must be presented as proof of warranty coverage, and should be included in any shipment of the product. Please also include in any mailing a contact name, company, address, and a description of the problem(s).
3. For the name of the nearest Kramer authorized service center, consult your authorized dealer.

LIMITATION OF IMPLIED WARRANTIES

All implied warranties, including warranties of merchantability and fitness for a particular purpose, are limited in duration to the length of this warranty.

EXCLUSION OF DAMAGES

The liability of Kramer for any effective products is limited to the repair or replacement of the product at our option. Kramer shall not be liable for:

1. Damage to other property caused by defects in this product, damages based upon inconvenience, loss of use of the product, loss of time, commercial loss; or;
2. Any other damages, whether incidental, consequential or otherwise. Some countries may not allow limitations on how long an implied warranty lasts and/or do not allow the exclusion or limitation of incidental or consequential damages, so the above limitations and exclusions may not apply to you.

This warranty gives you specific legal rights, and you may also have other rights, which vary from place to place.

NOTE: All products returned to Kramer for service must have prior approval. This may be obtained from your dealer.

This equipment has been tested to determine compliance with the requirements of:

- EN-50081: "Electromagnetic compatibility (EMC);
generic emission standard.
Part 1: Residential, commercial and light industry"
- EN-50082: "Electromagnetic compatibility (EMC) generic immunity standard.
Part 1: Residential, commercial and light industry environment".
- CFR-47:
FCC Rules and Regulations:
Part 15: "Radio frequency devices
Subpart B – Unintentional radiators"

CAUTION!

- ☒ Servicing the machines can only be done by an authorized Kramer technician. Any user who makes changes or modifications to the unit without the expressed approval of the manufacturer will void user authority to operate the equipment.
- ☒ Use the supplied DC power supply to feed power to the machine.
- ☒ Please use recommended interconnection cables to connect the machine to other components.



For the latest information on our products and a list of Kramer distributors, visit our Web site: www.kramerelectronics.com, where updates to this user manual may be found. We welcome your questions, comments and feedback.



Caution

Safety Warning:

Disconnect the unit from the power supply before opening/servicing.



Kramer Electronics, Ltd.

Web site: www.kramerelectronics.com

E-mail: info@kramerel.com

P/N: 2900-000081 REV 2