

Kramer Electronics, Ltd.



USER MANUAL

Model:

SID-X1

Step-In Commander

Contents

1	Introduction	1
2	Getting Started	1
2.1	Quick Start	1
3	Overview	3
3.1	DDC Support	3
3.2	Defining EDID	3
3.3	About HDMI	4
3.4	Using Twisted Pair Cable	5
4	Defining the SID-X1 Step-In Commander	6
5	Connecting the SID-X1 Step-In Commander	8
5.1	Connecting the Remote Step-In Switch and LED	9
5.2	Connecting the Remote Select Switch and LED	9
5.3	Connecting the Remote Input Selection LEDs	10
6	Operating the SID-X1 Locally via the Front Panel Buttons	11
6.1	Selecting an Input	11
6.2	Taking Control of the Switcher Input	11
6.3	Audio Stream Priority	11
7	Technical Specifications	12
8	Default EDID	13
8.1	HDMI, DisplayPort and DVI Default EDID	13
8.2	PC-UXGA Default EDID	14
Figures		
	Figure 1: SID-X1 Step-In Commander Front Panel	6
	Figure 2: SID-X1 Step-In Commander Rear Panel	7
	Figure 3: Connecting the SID-X1 Step-In Commander	8
	Figure 4: REMOTE STEP-IN Switch and LED Wiring	9
	Figure 5: REMOTE SELECT Switch and LED Wiring	9
	Figure 6: Remote Input Indicator LED Wiring	10
	Figure 7: Remote Input Indicator LED Wiring for the DVI Input	10
Tables		
	Table 1: SID-X1 Step-In Commander Front Panel Features	6
	Table 2: SID-X1 Step-In Commander Rear Panel Features	7
	Table 3: Technical Specifications of the SID-X1	12

1 Introduction

Welcome to Kramer Electronics! Since 1981, Kramer Electronics has been providing a world of unique, creative, and affordable solutions to the vast range of problems that confront the video, audio, presentation, and broadcasting professional on a daily basis. In recent years, we have redesigned and upgraded most of our line, making the best even better! Our 1,000-plus different models now appear in 11 groups¹ that are clearly defined by function.

Congratulations on purchasing your Kramer **SID-X1 Step-In Commander**.

The **SID-X1** is ideal for:

- Display systems requiring simple input selection
- Remote monitoring of computer activity in schools and businesses
- Rental/staging applications
- Multimedia and presentation source selection

The package includes the following items:

- **SID-X1 Step-In Commander**
- Power adapter (12V DC output)
- This user manual²

2 Getting Started

We recommend that you:

- Unpack the equipment carefully and save the original box and packaging materials for possible future shipment
- Review the contents of this user manual
- Use Kramer high performance high resolution cables³

2.1 Quick Start

This quick start chart summarizes the basic setup and operation steps.

1 GROUP 1: Distribution Amplifiers; GROUP 2: Switchers and Matrix Switchers; GROUP 3: Control Systems; GROUP 4: Format/Standards Converters; GROUP 5: Range Extenders and Repeaters; GROUP 6: Specialty AV Products; GROUP 7: Scan Converters and Scalers; GROUP 8: Cables and Connectors; GROUP 9: Room Connectivity; GROUP 10: Accessories and Rack Adapters; GROUP 11: Sierra Products

2 Download up-to-date Kramer user manuals from <http://www.kramerelectronics.com>

3 The complete list of Kramer cables is available from <http://www.kramerelectronics.com>

Step 1: Mount the device - see Section 5

Mount the machine in a rack (using the optional kit) or stick the 4 rubber feet to the underside and place on a shelf



Step 2: Connect the inputs and output - see Section 6

- 1 Connect the inputs
- 2 Connect the output
- 3 Optional - Connect a remote step-in switch and LED
- 4 Optional - Connect a remote input selection switch and LED
- 5 Optional - Connect the input indicator LEDs

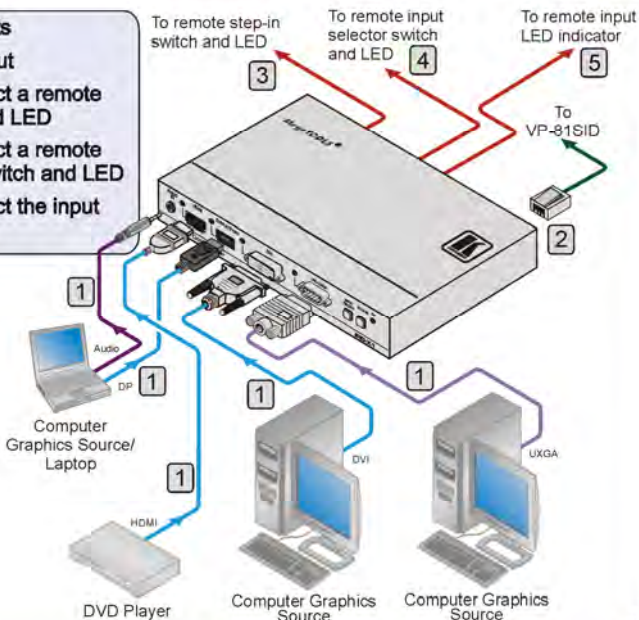

Step 3: Connect the power adapter

Step 4: Operate the device - see Section 7

Press STEP-IN to activate the switcher Input for the SID-X1

Press the INPUT SELECT button repeatedly until the required input is active as indicated by the relevant LED

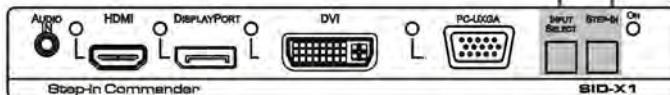

3 Overview

The **SID-X1** accepts an HDMI, DisplayPort, DVI and PC graphics video input, as well as an unbalanced stereo audio input (which is embedded into the output signal), and transmits the signal via TP (Twisted Pair) cable to a compatible switcher (for example, the **VP-81SID**). The step-in function of the **SID-X1** also controls the input and output selection of the switcher it is connected to.

In particular, the **SID-X1**:

- Supports DDC (Display Data Channel) communication between the selected input and output on 15-pin HD connector pins 12 and 15
- Provides EDID capture – Copies and stores the EDID from a display device
- Supports HDMI with Deep Color, x.v.Color™ and 3D
- Can be installed up to 50m (164ft) from the switcher
- Features automatic live input detection when connected to a single input

You can control the **SID-X1** using the front panel buttons, or remotely via contact closure switches.

To achieve the best performance:

- Connect only good quality connection cables, thus avoiding interference, deterioration in signal quality due to poor matching, and elevated noise levels (often associated with low quality cables)
- Avoid interference from neighboring electrical appliances that may adversely influence signal quality and position your **SID-X1** away from moisture, excessive sunlight and dust

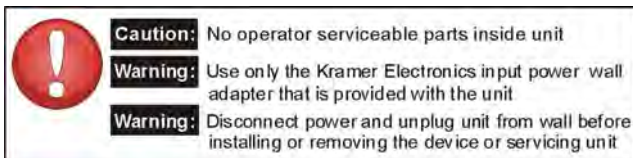

3.1 DDC Support

When establishing a VGA connection between a PC or laptop and a display device, a set of parameters known as EDID which is carried over the DDC channel is exchanged between them. In some PC graphic cards and laptops, this information exchange is essential for proper VGA OUT operation.

3.2 Defining EDID

The Extended Display Identification Data (EDID¹) is a data-structure, provided by a display that describes its capabilities to a graphics card (that is connected to the

¹ Defined by a standard published by the Video Electronics Standards Association (VESA)

display's source). The EDID enables the PC or laptop to "know" what kind of monitor is connected to the output. The EDID includes the manufacturer's name, product type, timing data supported by the display, display size, luminance data and (for digital displays only) pixel mapping data.

3.3 About HDMI

High-Definition Multimedia Interface (HDMI) is an uncompressed all-digital¹ audio/video interface, widely supported in the entertainment and home cinema industry. It delivers the highest high-definition image and sound quality. Note that Kramer Electronics Limited is an HDMI Adopter and an HDCP Licensee.

In particular, HDMI²:

- Provides a simple³ interface between any audio/video source, such as a set-top box, DVD player, or A/V receiver and video monitor, such as a digital flat LCD / plasma television (DTV), over a single lengthy⁴ cable
- Supports standard, enhanced, high-definition video, and multi-channel digital audio⁵ on a single cable
- Transmits all ATSC HDTV standards and supports 8-channel digital audio, with bandwidth to spare to accommodate future enhancements and requirements
- Benefits consumers by providing superior, uncompressed digital video quality via a single cable⁶, and user-friendly connector
- Is backward-compatible with DVI (Digital Visual Interface)
- Supports two-way CEC communication between the video source (such as a DVD player) and the digital television, enabling new functionality such as automatic configuration and one-button play

HDMI has the capacity to support existing high-definition video formats (720p, 1080i, and 1080p, 2K and 4K), standard definition formats such as NTSC or PAL, as well as 480p and 576p.

1 Ensuring an all-digital rendering of video without the losses associated with analog interfaces and their unnecessary digital-to-analog conversions

2 HDMI, the HDMI logo and High-Definition Multimedia Interface are trademarks or registered trademarks of HDMI licensing LLC

3 With video and multi-channel audio combined into a single cable, the cost, complexity, and confusion of multiple cables currently used in A/V systems is reduced

4 HDMI technology has been designed to use standard copper cable construction at up to 15m

5 HDMI supports multiple audio formats, from standard stereo to multi-channel surround-sound HDMI has the capacity to support Dolby 5.1 audio and high-resolution audio formats

6 HDMI provides the quality and functionality of a digital interface while also supporting uncompressed video formats in a simple, cost-effective manner

3.4 Using Twisted Pair Cable

Kramer engineers have developed special twisted pair cables to best match our digital twisted pair products; the Kramer **BC-DGKat623** (CAT 6 23 AWG cable), and the Kramer **BC-DGKat7a23** (CAT 7a 23 AWG cable). These specially built cables significantly outperform regular CAT 5/CAT 6/CAT 7a cables.

4 Defining the SID-X1 Step-In Commander

[Figure 1](#) and [Table 1](#) define the front panel of the **SID-X1 Step-In Commander**.

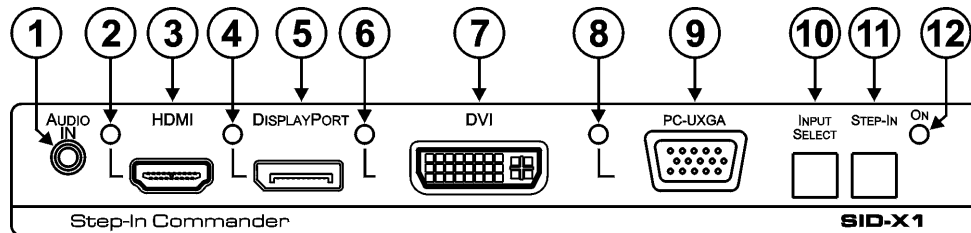

Figure 1: SID-X1 Step-In Commander Front Panel

Table 1: SID-X1 Step-In Commander Front Panel Features

#	Feature	Function
1	AUDIO IN 3.5mm Mini Jack	Connect to an unbalanced stereo audio source
2	HDMI LED	Lights green when the HDMI input is selected
3	HDMI Connector	Connect to an HDMI source
4	DisplayPort LED	Lights green when the DisplayPort input is selected
5	DisplayPort Connector	Connect to a DisplayPort source
6	DVI LED	Lights green when the DVI input is selected
7	DVI Connector	Connect to a DVI source
8	PC-UXGA LED	Lights green when the PC-UXGA input is selected
9	PC-UXGA 15-pin HD Connector (F)	Connect to a PC graphics source
10	INPUT SELECT Button	Press repeatedly to cycle and select one of the inputs to switch to the output
11	STEP-IN Button	Press to activate the input on the switcher that the SID-X1 is connected to
12	ON LED	Lights green when the device is powered on

Defining the SID-X1 Step-In Commander

[Figure 2](#) and [Table 2](#) define the rear panel of the **SID-X1 Step-In Commander**.

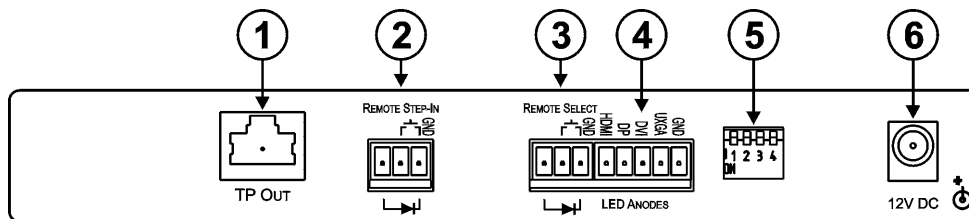

Figure 2: SID-X1 Step-In Commander Rear Panel

Table 2: SID-X1 Step-In Commander Rear Panel Features

#	Feature	Function
1	TP OUT RJ-45 Connector	Connect to a compatible switcher, for example, VP-81SID using CAT 6 or higher specification cable
2	REMOTE STEP-IN 3-way Terminal Block	Connect to the remote, contact closure step-in switch and LED (see Section 5.1)
3	REMOTE SELECT 3-way Terminal Block	Connect to the remote, contact closure input selection switch and LED (see Section 5.2)
4	HDMI, DP, DVI, UXGA, GND, LED ANODES 5-way Terminal Block	Connect to the remote input indicator LEDs (see Section 5.3)
5	DIP-switch	For the use of Kramer service personnel only. Has no effect during normal operation
6	12V DC Power Connector	Connect to supplied power adapter, center pin positive

5 Connecting the SID-X1 Step-In Commander

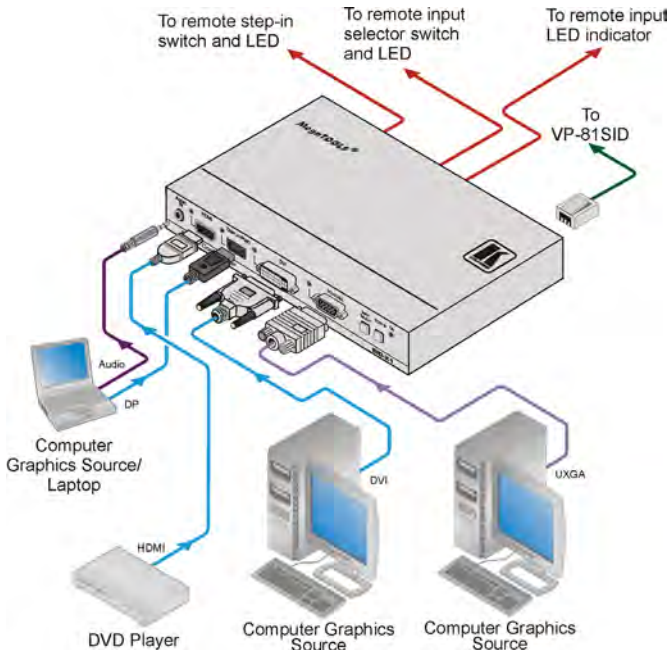

Figure 3: Connecting the SID-X1 Step-In Commander

To connect¹ the SID-X1, as illustrated in the example in [Figure 3](#):

1. Connect up to four video sources (HDMI, DisplayPort, DVI and PC graphics) to the video input connectors.
Note: If only one live input is connected, the device automatically detects the live port and activates it.
2. Connect the unbalanced stereo audio source to the AUDIO IN 3.5mm mini jack connector.
3. Connect the TP OUT RJ-45 connector to a compatible switcher (for example, **VP-81SID**) up to 50m (164ft) away.
4. Optional—Connect the REMOTE STEP-IN 3-way terminal block to a contact closure switch and LED (see [Section 5.1](#)).
5. Optional—Connect the REMOTE SELECT 3-way terminal block to a contact closure switch and LEDs (see [Section 5.2](#)).
6. Optional—Connect the LED ANODES 5-way terminal block to the remote input indicator LEDs (see [Section 5.3](#)).

¹ Be sure that the power is switched off on each device before connecting it to your SID-X1. After connecting all the devices to your SID-X1, switch on the power of the SID-X1, and then switch on the power of each device.

7. Connect the power adapter to the **SID-X1** and to the mains power.

5.1 Connecting the Remote Step-In Switch and LED

You can connect a remote, contact closure step-in switch to take control of the input of the attached switcher, as well as a remote step-in LED to the REMOTE STEP-IN terminal block on the rear panel of the **SID-X1**.

[Figure 4](#) illustrates the connections from the terminal block to the switch and LED.

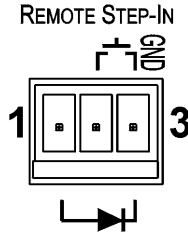

Figure 4: REMOTE STEP-IN Switch and LED Wiring

To connect a remote step-in switch and LED as illustrated in the example in [Figure 4](#):

1. Connect pins 2 and 3 from the terminal block to the remote step-in switch.
2. Connect pin 1 from the terminal block to the anode of the remote step-in LED.
3. Connect pin 3 from the terminal block to the cathode of the remote step-in LED.

5.2 Connecting the Remote Select Switch and LED

You can connect a remote, contact closure, input selection switch to activate an input, as well as an indicator LED to the terminal block on the rear panel of the **SID-X1**.

[Figure 5](#) illustrates the connections from the terminal block to the switch and LED.

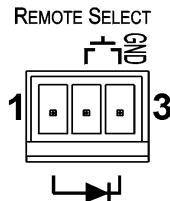

Figure 5: REMOTE SELECT Switch and LED Wiring

To connect a remote selection switch and LED as illustrated in the example in [Figure 5](#):

1. Connect pins 2 and 3 from the terminal block to the remote selection switch.
2. Connect pin 1 from the terminal block to the anode of the remote selection LED.
3. Connect pin 3 from the terminal block to the cathode of the remote selection LED.

5.3 Connecting the Remote Input Selection LEDs

You can connect remote, input selection LEDs to the LED terminal block on the rear panel of the **SID-X1** to indicate which is the active input. Momentary connection is sufficient to switch inputs.

[Figure 6](#) illustrates the connections from the terminal block to the LEDs.

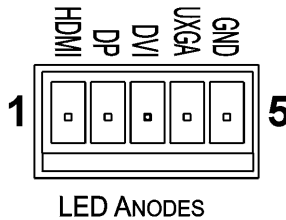

Figure 6: Remote Input Indicator LED Wiring

To connect remote input indicator LEDs:

1. Connect pin 1 from the terminal block to the anode of the remote HDMI indicator LED.
2. Connect pin 2 from the terminal block to the anode of the remote DP indicator LED.
3. Connect pin 3 from the terminal block to the anode of the remote DVI indicator LED (see the example in [Figure 7](#)).
4. Connect pin 4 from the terminal block to the anode of the remote UXGA indicator LED.
5. Connect pin 5 from the terminal block to the cathodes of each LED.

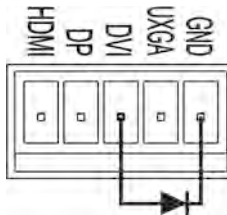

Figure 7: Remote Input Indicator LED Wiring for the DVI Input

6 Operating the SID-X1 Locally via the Front Panel Buttons

Powering up the **SID-X1** recalls the last settings (that is, the configuration of the device when it was powered down) from the non-volatile memory.

6.1 Selecting an Input

To select an input, press the INPUT SELECT button repeatedly until the required input is active as indicated by the associated LED.

Note: If only one live input is connected, the device automatically detects the live port and activates it. If more than one input is connected, you must select the required input by pressing the INPUT SELECT button until the associated LED lights.

6.2 Taking Control of the Switcher Input

To activate the input of the switcher to which the **SID-X1** is connected, press the STEP-IN button. If the switcher grants the **SID-X1** access to the input, the STEP-IN button lights. If the switcher does not grant access for some reason, the button flashes for a few seconds and then does not light. This may be because the switcher input connected to the **SID-X1** has been set to have a lower priority than the currently active input.

Note: Input priority on the switcher is set using the Kramer Control Software¹.

6.3 Audio Stream Priority

An audio source connected to the 3.5mm mini jack Audio Input takes priority over any other audio stream. This means that if there is an audio source connected to the 3.5mm mini jack and the HDMI and DVI streams also contain audio, only the audio source from the 3.5mm audio jack is transmitted over the TP to the switcher.

¹ Go to <http://www.kramerelectronics.com> to download the latest version of the software

7 Technical Specifications

[Table 3](#) lists the technical specifications¹ of the **SID-X1**.

Table 3: Technical Specifications of the SID-X1

INPUTS:	Video:	1 HDMI on an HDMI connector 1 DP on a DisplayPort connector 1 DVI on a DVI connector 1 VGA on a 15-pin HD (F) connector
	Audio:	1 Unbalanced stereo audio on a 3.5mm mini jack
OUTPUTS:	1 TP on an RJ-45	
STANDARDS:	HDMI with Deep Color, x.v.Color™ and 3D	
MAXIMUM STEP-IN DISTANCE:	50m (164ft) up to 1080p @60Hz	
POWER SOURCE:	12V DC, 800mA	
OPERATING TEMPERATURE:	0° to +55°C (32° to 131°F)	
STORAGE TEMPERATURE:	-45° to +72°C (-49° to 162°F)	
HUMIDITY:	10% to 90%, RHL non-condensing	
DIMENSIONS:	18.8cm x 11.3cm x 2.5cm (7.4" x 4.5" x 1") W, D, H rack-mountable	
WEIGHT:	0.48 kg (1.1lbs) approx.	
ACCESSORIES:	Power adapter	
OPTIONS:	19" Rack adapter RK-T2B, RTBUS-12, RTBUS-21	

¹ Specifications are subject to change without notice

8 Default EDID

Each input on the **SID-X1** is loaded with a factory default EDID.

8.1 HDMI, DisplayPort and DVI Default EDID

```

Monitor
Model name..... S D-X1
Manufacturer..... KRM
Plug and Play D..... KRM1200
Serial number..... 505-709990100
Manufacture date..... 2011, ISO week 255
-----
EDID revision..... 1 3
Input signal type..... Digital
Color bit depth..... Undefined
Display type..... RGB color
Screen size..... 520 x 320 mm (24 0 in)
Power management..... Standby, Suspend, Active off/sleep
Extension blocs..... 1 (CEA-EXT)
-----
DDC/CI..... n/a

Color characteristics
Default color space..... Non-sRGB
Display gamma..... 2.20
Red chromaticity..... Rx 0.674 - Ry 0.319
Green chromaticity..... Gx 0.188 - Gy 0.706
Blue chromaticity..... Bx 0.148 - By 0.064
White point (default).... Wx 0.313 - Wy 0.329
Additional descriptors... None

Timing characteristics
Horizontal scan range.... 30-83kHz
Vertical scan range..... 56-76Hz
Video bandwidth..... 170MHz
CVT standard..... Not supported
GTF standard..... Not supported
Additional descriptors... None
Preferred timing..... Yes
Native/preferred timing.. 1280x720p at 60Hz (16:10)
  Modeline..... "1280x720" 74.250 1280 1390 1430 1650 720 725 730 750 +hsync +vsync

Standard timings supported
  720 x 400p at 70Hz - BM VGA
  640 x 480p at 60Hz - BM VGA
  640 x 480p at 75Hz - VESA
  800 x 600p at 60Hz - VESA
  800 x 600p at 75Hz - VESA
  1024 x 768p at 60Hz - VESA
  1024 x 768p at 75Hz - VESA
  1280 x 1024p at 75Hz - VESA
  1280 x 1024p at 60Hz - VESA STD
  1600 x 1200p at 60Hz - VESA STD
  1152 x 864p at 75Hz - VESA STD

EIA/CEA-861 Information
Revision number..... 3
IT underscan..... Supported
Basic audio..... Supported
YCbCr 4:4:4..... Supported
YCbCr 4:2:2..... Supported
Native formats..... 1
Detailed timing #1..... 1920x1080p at 60Hz (16:10)
  Modeline..... "1920x1080" 148.500 1920 2008 2052 2200 1080 1084 1089 1125 +hsync +vsync
Detailed timing #2..... 1920x1080i at 60Hz (16:10)
  Modeline..... "1920x1080" 74.250 1920 2008 2052 2200 1080 1084 1094 1124 interlace +hsync +vsync
Detailed timing #3..... 1280x720p at 60Hz (16:10)
  Modeline..... "1280x720" 74.250 1280 1390 1430 1650 720 725 730 750 +hsync +vsync
Detailed timing #4..... 720x480p at 60Hz (16:10)

```

Default EDID

Blue chromaticity..... Bx 0.148 - By 0.064
White point (default).... Wx 0.313 - Wy 0.329
Additional descriptors... None

Timing characteristics

Horizontal scan range.... 30-83kHz
Vertical scan range..... 56-76Hz
Video bandwidth..... 170MHz
CVT standard..... Not supported
GTF standard..... Not supported
Additional descriptors... None
Preferred timing..... Yes
Native/preferred timing.. 1280x720p at 60Hz (16:10)
Modeline..... "1280x720" 74.250 1280 1390 1430 1650 720 725 730 750 +hsync +vsync

Standard timings supported

720 x 400p at 70Hz - BM VGA
640 x 480p at 60Hz - BM VGA
640 x 480p at 75Hz - VESA
800 x 600p at 60Hz - VESA
800 x 600p at 75Hz - VESA
1024 x 768p at 60Hz - VESA
1024 x 768p at 75Hz - VESA
1280 x 1024p at 75Hz - VESA
1280 x 1024p at 60Hz - VESA STD
1600 x 1200p at 60Hz - VESA STD
1152 x 864p at 75Hz - VESA STD

EIA/CEA-861 Information

Revision number..... 3
IT underscan..... Supported
Basic audio..... Supported
YCbCr 4:4:4..... Supported
YCbCr 4:2:2..... Supported
Native formats..... 1
Detailed timing #1..... 1920x1080p at 60Hz (16:10)
Modeline..... "1920x1080" 148.500 1920 2008 2052 2200 1080 1084 1089 1125 +hsync +vsync
Detailed timing #2..... 1920x1080i at 60Hz (16:10)
Modeline..... "1920x1080" 74.250 1920 2008 2052 2200 1080 1084 1094 1124 interlace +hsync +vsync
Detailed timing #3..... 1280x720p at 60Hz (16:10)
Modeline..... "1280x720" 74.250 1280 1390 1430 1650 720 725 730 750 +hsync +vsync
Detailed timing #4..... 720x480p at 60Hz (16:10)
Modeline..... "720x480" 27.000 720 736 798 858 480 489 495 525 -hsync -vsync

CE video identifiers (VICs) - timing/formats supported

1920 x 1080p at 60Hz - HDTV (16 9, 1:1)
1920 x 1080i at 60Hz - HDTV (16 9, 1:1)
1280 x 720p at 60Hz - HDTV (16:9, 1:1) [Native]
720 x 480p at 60Hz - EDTV (16:9, 32:27)
720 x 480p at 60Hz - EDTV (4 3, 8:9)
720 x 480i at 60Hz - Doublescan (16 9, 32 27)
720 x 576i at 50Hz - Doublescan (16 9, 64:45)
640 x 480p at 60Hz - Default (4 3, 1:1)
NB: NTSC refresh rate = (Hz*1000)/1001

CE audio data (formats supported)

LPCM 2-channel, 16/20/24 bit depths at 32/44/48 kHz

CE vendor specific data (VSDB)

IEEE registration number. 0x000C03
CEC physical address..... 1.1.0.0
Maximum TMDS clock..... 165MHz

CE speaker allocation data

Channel configuration.... 2.0
Front left/right..... Yes
Front LFE..... No
Front center..... No
Rear left/right..... No
Rear center..... No
Front left/right center.. No
Rear left/right center... No



LIMITED WARRANTY

We warrant this product free from defects in material and workmanship under the following terms.

HOW LONG IS THE WARRANTY

Labor and parts are warranted for seven years from the date of the first customer purchase.

WHO IS PROTECTED?

Only the first purchase customer may enforce this warranty.

WHAT IS COVERED AND WHAT IS NOT COVERED

Except as below, this warranty covers all defects in material or workmanship in this product. The following are not covered by the warranty:

1. Any product which is not distributed by us or which is not purchased from an authorized Kramer dealer. If you are uncertain as to whether a dealer is authorized, please contact Kramer at one of the agents listed in the Web site www.kramerelectronics.com.
2. Any product, on which the serial number has been defaced, modified or removed, or on which the WARRANTY VOID IF TAMPERED sticker has been torn, reattached, removed or otherwise interfered with.
3. Damage, deterioration or malfunction resulting from:
 - i) Accident, misuse, abuse, neglect, fire, water, lightning or other acts of nature
 - ii) Product modification, or failure to follow instructions supplied with the product
 - iii) Repair or attempted repair by anyone not authorized by Kramer
 - iv) Any shipment of the product (claims must be presented to the carrier)
 - v) Removal or installation of the product
 - vi) Any other cause, which does not relate to a product defect
 - vii) Cartons, equipment enclosures, cables or accessories used in conjunction with the product

WHAT WE WILL PAY FOR AND WHAT WE WILL NOT PAY FOR

We will pay labor and material expenses for covered items. We will not pay for the following:

1. Removal or installations charges.
2. Costs of initial technical adjustments (set-up), including adjustment of user controls or programming. These costs are the responsibility of the Kramer dealer from whom the product was purchased.
3. Shipping charges.

HOW YOU CAN GET WARRANTY SERVICE

1. To obtain service on your product, you must take or ship it prepaid to any authorized Kramer service center.
2. Whenever warranty service is required, the original dated invoice (or a copy) must be presented as proof of warranty coverage, and should be included in any shipment of the product. Please also include in any mailing a contact name, company, address, and a description of the problem(s).
3. For the name of the nearest Kramer authorized service center, consult your authorized dealer.

LIMITATION OF IMPLIED WARRANTIES

All implied warranties, including warranties of merchantability and fitness for a particular purpose, are limited in duration to the length of this warranty.

EXCLUSION OF DAMAGES

The liability of Kramer for any effective products is limited to the repair or replacement of the product at our option. Kramer shall not be liable for:

1. Damage to other property caused by defects in this product, damages based upon inconvenience, loss of use of the product, loss of time, commercial loss; or:
2. Any other damages, whether incidental, consequential or otherwise. Some countries may not allow limitations on how long an implied warranty lasts and/or do not allow the exclusion or limitation of incidental or consequential damages, so the above limitations and exclusions may not apply to you.

This warranty gives you specific legal rights, and you may also have other rights, which vary from place to place.

NOTE: All products returned to Kramer for service must have prior approval. This may be obtained from your dealer.

This equipment has been tested to determine compliance with the requirements of:

- EN-50081: "Electromagnetic compatibility (EMC); generic emission standard.
Part 1: Residential, commercial and light industry"
- EN-50082: "Electromagnetic compatibility (EMC) generic immunity standard.
Part 1: Residential, commercial and light industry environment".
- CFR-47: FCC* Rules and Regulations:
Part 15: "Radio frequency devices
Subpart B Unintentional radiators"

CAUTION

- Servicing the machines can only be done by an authorized Kramer technician. Any user who makes changes or modifications to the unit without the expressed approval of the manufacturer will void user authority to operate the equipment.
 - Use the supplied DC power supply to feed power to the machine.
 - Please use recommended interconnection cables to connect the machine to other components.
- * FCC and CE approved using STP cable (for twisted pair products)



For the latest information on our products and a list of Kramer distributors, visit www.kramerelectronics.com where updates to this user manual may be found. We welcome your questions, comments and feedback.



Caution

Safety Warning:

Disconnect the unit from the power supply before opening/servicing.



Kramer Electronics, Ltd.

Web site: www.kramerelectronics.com

E-mail: info@kramereel.com

P/N: 2900-000754 REV 1