

Kramer Electronics, Ltd.



USER MANUAL

Model:

TP-205A

XGA/Audio/RS-232 Line Transmitter/DA

Contents

1	Introduction	1
2	Getting Started	1
2.1	Quick Start	2
3	Overview	3
3.1	About the Power Connect Feature	3
3.2	Shielded Twisted Pair (STP)/Unshielded Twisted Pair (UTP)	3
3.3	Recommendations for Achieving the Best Performance	4
4	Your TP-205A	5
5	Configuring the TP-205A	6
5.1	Connecting the TP-205A	7
5.2	Looping the TP-205A	9
5.3	Wiring the CAT 5 LINE IN / LINE OUT RJ-45 Connectors	10
5.4	Controlling via RS-232 (for example, using a PC)	10
6	Technical Specifications	11

Figures

Figure 1:	TP-205A	5
Figure 2:	TP-205A Underside	6
Figure 3:	Connecting the XGA/Audio/Data Line Transmitter/Receiver System	8
Figure 4:	Looping the TP-205A	9
Figure 5:	CAT 5 PINOUT	10
Figure 6:	RS-232 PINOUT Connection	10

Tables

Table 1:	TP-205A Features	5
Table 2:	Features of the TP-205A Underside	6
Table 3:	CAT 5 PINOUT	10
Table 4:	RS-232 PINOUT Connection	10
Table 5:	Technical Specifications of the TP-205A	11

1 Introduction

Welcome to Kramer Electronics! Since 1981, Kramer Electronics has been providing a world of unique, creative, and affordable solutions to the vast range of problems that confront the video, audio, presentation, and broadcasting professional on a daily basis. In recent years, we have redesigned and upgraded most of our line, making the best even better! Our 1,000-plus different models now appear in 11 groups¹ that are clearly defined by function.

Thank you for purchasing the Kramer **TP-205A XGA/Audio/RS-232 Line Transmitter/DA**, which is ideal for:

- Presentation and multimedia applications
- Long-range graphics distribution for schools, hospitals, security, and stores

The package includes the following items:

- **TP-205A XGA/Audio/RS-232 Line Transmitter/DA**
- Power supply (12V DC)
- This user manual²

2 Getting Started

We recommend that you:

- Unpack the equipment carefully and save the original box and packaging materials for possible future shipment
- Review the contents of this user manual
- Use Kramer high performance high-resolution cables³

1 GROUP 1: Distribution Amplifiers; GROUP 2: Switchers and Matrix Switchers; GROUP 3: Control Systems; GROUP 4: Format/Standards Converters; GROUP 5: Range Extenders and Repeaters; GROUP 6: Specialty AV Products; GROUP 7: Scan Converters and Scalers; GROUP 8: Cables and Connectors; GROUP 9: Room Connectivity; GROUP 10: Accessories and Rack Adapters; GROUP 11: Sierra Products

2 Download up-to-date Kramer user manuals from our Web site at <http://www.kramerelectronics.com>

3 The complete list of Kramer cables is on our Web site at <http://www.kramerelectronics.com>

2.1 Quick Start

The quick start charts summarize the basic setup and operation steps of the TP-205A.

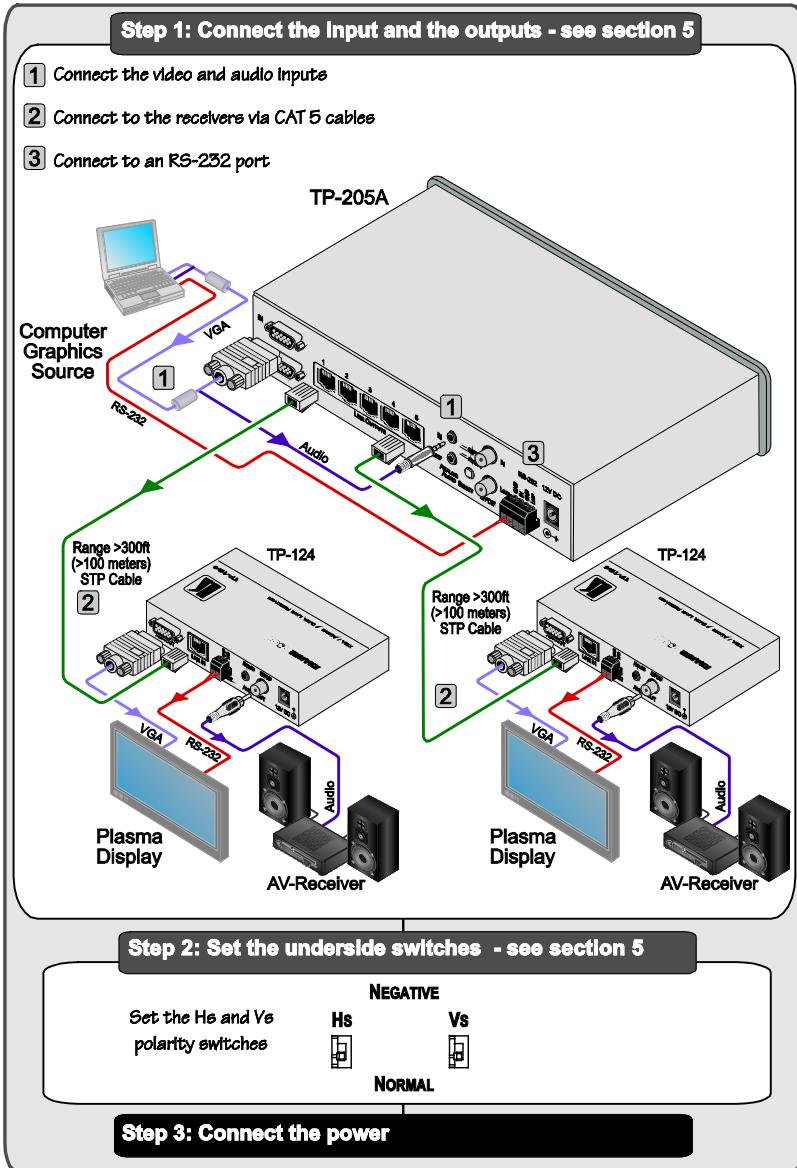

3 Overview

The **TP-205A** is a high-performance transmitter. It accepts a computer graphics input signal, a selectable unbalanced stereo analog audio signal or a digital audio (S/PDIF) signal, and unidirectional (TxD) RS-232 control commands (that can be embedded when the S/PDIF ANALOG Selector Button is set to the analog state). It transmits to up to five receivers (via CAT 5 cables).

In addition, the **TP-205A**:

- Has a resolution of up to UXGA
- Can be looped to an additional **TP-205A** transmitter
- Has a transmission range of more than 300feet (more than 100 meters) over UTP cabling
- Can power the receivers over the same CAT 5 cable, and is 12V DC fed

3.1 About the Power Connect Feature

The Power Connect feature applies as long as the cable can carry power. This feature is available when using STP cable and the distance does not exceed 50m on standard CAT 5 cable. For longer distances, heavy gauge cable should be used¹. For units which are connected via RJ-45 connectors, make sure that the shield of the STP cable is connected to the metal casing of the connectors on both ends of the cable. For units which are connected via terminal block connectors, the shield of the STP cable must be connected to a ground terminal on the units at both ends (use the ground terminal of the power supply connection if necessary).

For a CAT 5 cable exceeding a distance of 50m, separate power supplies should be connected to the transmitter and to the receiver simultaneously.

3.2 Shielded Twisted Pair (STP)/Unshielded Twisted Pair (UTP)

We recommend that you use Shielded Twisted Pair (STP) cable. There are different levels of STP cable available, and we advise you to use the best quality STP cable that you can afford. Our non-skew-free cable, Kramer **BC-STP** is intended for analog signals where skewing is not an issue. For cases where there is skewing, our UTP skew-free cable, Kramer **BC-XTP**, may be used. Bear in mind, though, that we advise using STP cables where possible, since the compliance to electromagnetic interference was tested using those cables.

¹ CAT 5 cable is still suitable for the video/audio transmission, but not for feeding the power at these distances

Although Unshielded Twisted Pair (UTP) cable might be preferred for long range applications, the UTP cable should be installed far away from electric cables, motors and so on, which are prone to create electrical interference. However, since the use of UTP cable might cause inconformity to electromagnetic standards, Kramer does not commit to meeting the standard with UTP cable.

3.3 Recommendations for Achieving the Best Performance

To achieve the best performance:

- Use only good quality connection cables¹ to avoid interference, deterioration in signal quality due to poor matching, and elevated noise levels (often associated with low quality cables).
- Avoid interference from neighboring electrical appliances that may adversely influence signal quality and position your Kramer **TP-205A** away from moisture, excessive sunlight and dust

	Caution: No operator serviceable parts inside unit
	Warning: Use only the Kramer Electronics input power wall adapter that is provided with the unit
	Warning: Disconnect power and unplug unit from wall before installing or removing the device or servicing unit

¹ Available from Kramer Electronics on our Web site at <http://www.kramerelectronics.com>

4 Your TP-205A

[Figure 1](#) and [Table 1](#) define the **TP-205A**:

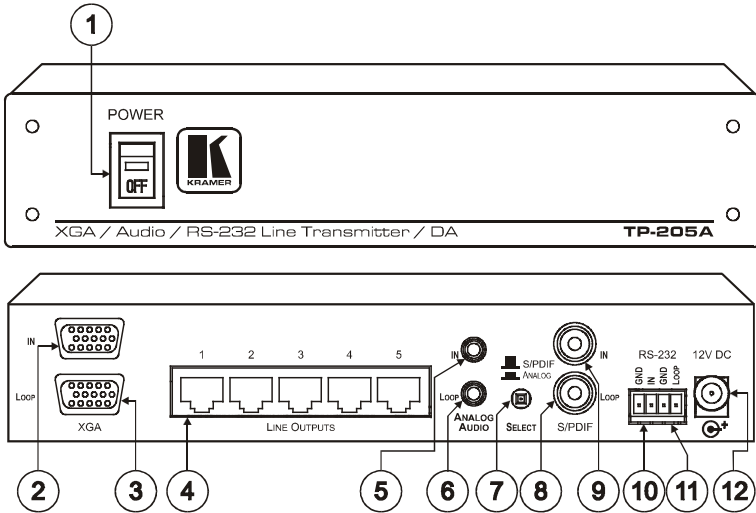

Figure 1: TP-205A

Table 1: TP-205A Features

#	Feature	Function	
1	POWER Switch	Illuminated switch for turning the unit ON or OFF	
2	XGA 15-pin HD Connector	IN	Connect to the computer graphics source
3		LOOP	Connect to a display or to the XGA IN connector of an additional TP-205A unit
4	LINE OUTPUTS RJ-45 Connectors	Connect to ¹ the LINE IN RJ-45 connector on a receiver ² (from 1 to 5)	
5	ANALOG AUDIO 3.5mm Mini Jack	IN	Connects to the unbalanced stereo analog audio source
6		LOOP	Connect to an unbalanced stereo analog audio acceptor or to the ANALOG AUDIO IN connector of an additional TP-205A unit
7	S/PDIF – ANALOG SELECT Selector Button ³	Release to select digital audio (S/PDIF) Press to select analog audio	
8	S/PDIF RCA Connector	LOOP	Connect to a digital audio acceptor or to the S/PDIF IN connector of an additional TP-205A unit
9		IN	Connect to the digital audio source
10	RS-232 Terminal Block Connector	IN	Connect the two connectors on the left (GND and IN) to a PC or remote controller (see section 5.3)
11		LOOP	Connect the two connectors on the right (GND and LOOP) to the GND and IN connectors of an additional TP-205A
12	12V DC	+12V DC connector for powering the unit	

1 Using a UTP CAT 5 cable with RJ-45 connectors at both ends (the PINOUT is defined in [Table 3](#) and [Figure 5](#))

2 For example, the Kramer TP-124, the Kramer TP-46, and so on

3 RS-232 can be embedded only when the S/PDIF ANALOG Selector Button is set to the analog state

[Figure 2](#) and [Table 2](#) define the underside of the **TP-205A**

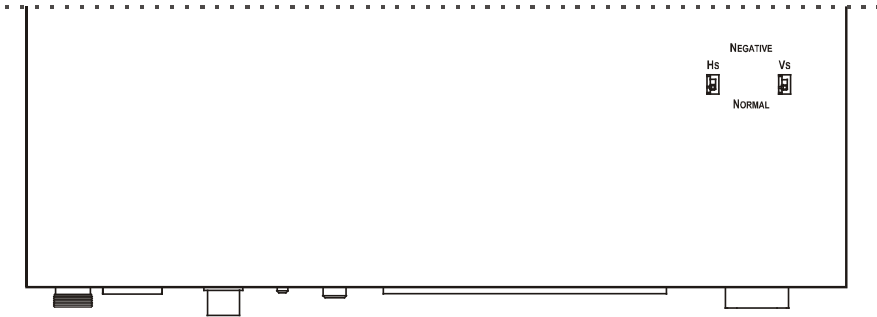

Figure 2: TP-205A Underside

Table 2: Features of the TP-205A Underside

Feature	Function
HS Switch ¹	Slide the switch up, to set the H SYNC to negative polarity (NEGATIVE) Slide the switch down, to set the H SYNC to its input polarity (NORMAL)
VS Switch ¹	Slide the switch up, to set the V SYNC to negative polarity (NEGATIVE) Slide the switch down, to set the V SYNC to its input polarity (NORMAL)

5 Configuring the TP-205A

This section describes how to:

- Connect the **TP-205A** (see section [5.1](#))
- Connect an additional **TP-205A** (see section [5.2](#))
- Wire the CAT 5 LINE IN/LINE OUT RJ-45 Connectors (see section [5.3](#))
- Control via RS-232 (see section [5.4](#))

¹ By default, both switches are set down (for normal V SYNC and H SYNC polarity)

5.1 Connecting the TP-205A

You can connect the **TP-205A** to up to five receivers. Use it to transmit the video, audio and RS-232 control signals via CAT 5 UTP cable.

To connect the **TP-205A** as illustrated in the example in [Figure 3](#), do the following:

1. Connect an XGA source (for example, a laptop's graphics card) to the XGA IN 15-pin HD connector and an audio source to the ANALOG AUDIO IN 3.5mm mini jack¹, for example, using a Kramer C-GMA/GMA cable (VGA 15-pin HD (M) +audio jack to VGA 15-pin HD (M) +audio jack)².
2. Press the SELECT button to select the ANALOG input³.
3. Connect an RS-232 cable with a 9-pin D-sub connector at one end to the laptop, and the other end to the 2 left-hand pins of the terminal block connector⁴ (GND and IN) on the **TP-205A** RS-232 port⁵.
4. Connect the LINE OUTPUT CAT 5 connectors as follows⁶:
 - The LINE OUT 1 RJ-45 connector on the TP-205A to the LINE IN RJ-45 connector on the TP-1247 via UTP cabling⁸ (with a range of more than 300ft (>100m))⁹
 - The LINE OUT 5 RJ-45 connector on the **TP-205A** to the LINE IN RJ-45 connector on the **TP-1247**, via UTP cabling⁸ (with a range of more than 300ft (>100m))
5. Connect the 12V DC power adapter to the power socket and connect the adapter to the mains electricity.
6. If necessary, set the H SYNC and V SYNC switches¹⁰ on the underside.

1 Or alternatively to the digital audio S/PDIF IN RCA connector

2 Not supplied. The full list of Kramer cables is on our Web site at <http://www.kramerelectronics.com>. Alternatively, you can connect an XGA source to the XGA IN 15-pin HD connector, and a separate audio source to the AUDIO IN 3.5mm mini jack

3 If the digital audio input is selected, release the SELECT button

4 The two right pins (GND and LOOP) can be connected to the GND and IN connectors on an additional TP-205A unit

5 As defined in [Figure 6](#) and [Table 4](#) (see section [5.3](#))

6 You do not have to connect all the outputs

7 Refer to the separate user manual, which can be downloaded from the Internet at <http://www.kramerelectronics.com>

8 For details of how to wire a CAT 5 LINE IN/LINE OUT RJ-45 connector, see section [5.3](#)

9 The TP-46 is connected to an additional TP-46 unit for transmitting the signal further

10 By default, both switches are set down (for normal V SYNC and H SYNC polarity)

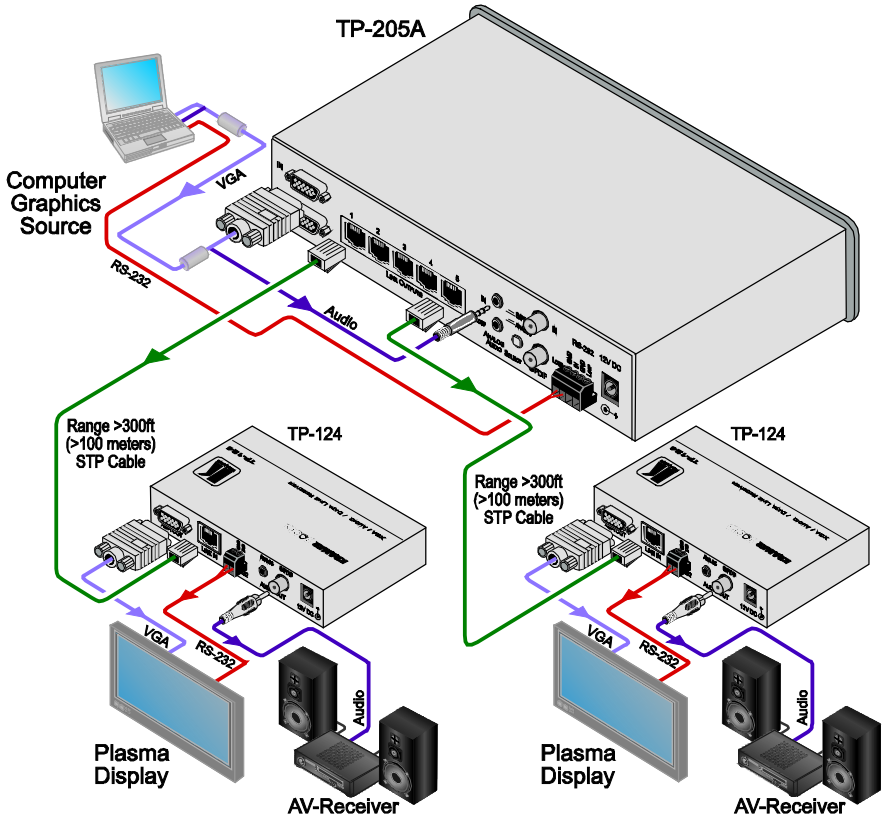

Figure 3: Connecting the XGA/Audio/Data Line Transmitter/Receiver System

5.2 Looping the TP-205A

You can loop two¹ TP-205A units to add further output signals to the system, as illustrated in the example in [Figure 4](#). In this example:

1. Connect the XGA LOOP 15-pin HD connector of the first TP-205A to the XGA IN 15-pin HD connector of the second TP-205A.
2. Connect the S/PDIF LOOP RCA connector of the first TP-205A to the S/PDIF LOOP RCA connector of the second TP-205A.
3. Connect the GND and LOOP right terminal block connectors of the first TP-205A to the GND and IN left terminal block connectors of the second TP-205A.
4. Connect the LINE OUTPUT RJ-45 connectors on each TP-205A unit, to the LINE IN RJ-45 connectors of various receivers, as illustrated in [Figure 4](#).
5. On each TP-205A unit, connect the 12V DC power adapter to the power socket and connect the adapter to the mains electricity.

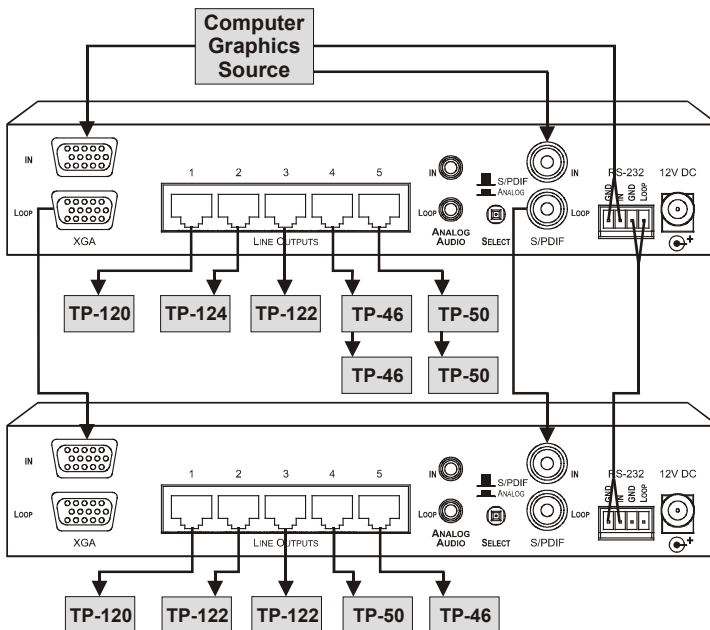

Figure 4: Looping the TP-205A

¹ The number of TP-205A units that can be looped depends upon the quality of the input signal that you require and the distance between the machines. We do not recommend cascading more than five TP-205A units

5.3 Wiring the CAT 5 LINE IN / LINE OUT RJ-45 Connectors

[Table 3](#) and [Figure 5](#) define the UTP CAT 5 PINOUT, using a straight pin to pin cable with RJ-45 connectors:

Table 3: CAT 5 PINOUT

EIA /TIA 568A		EIA /TIA 568B	
PIN	Wire Color	PIN	Wire Color
1	Green / White	1	Orange / White
2	Green	2	Orange
3	Orange / White	3	Green / White
4	Blue	4	Blue
5	Blue / White	5	Blue / White
6	Orange	6	Green
7	Brown / White	7	Brown / White
8	Brown	8	Brown
Pair 1	4 and 5	Pair 1	4 and 5
Pair 2	3 and 6	Pair 2	1 and 2
Pair 3	1 and 2	Pair 3	3 and 6
Pair 4	7 and 8	Pair 4	7 and 8

Figure 5: CAT 5 PINOUT

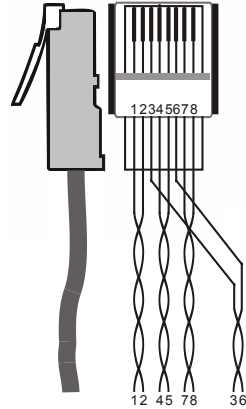

5.4 Controlling via RS-232 (for example, using a PC)

Prepare an RS-232 cable with a 9-pin D-sub connector at one end, and a 2 PIN terminal block connector at the other end, as defined in [Figure 6](#) and [Table 4](#):

Table 4: RS-232 PINOUT Connection

Attach the 9-pin D-sub Connector	To the Terminal Block Connector PIN:
PIN 3	IN
PIN 5	GND (on the left)

PC (Controller) to TP-205A

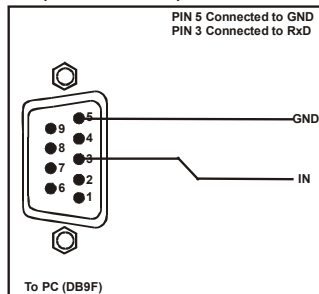

Figure 6: RS-232 PINOUT Connection

6 Technical Specifications

[Table 5](#) includes the technical specifications¹ of the **TP-205A**:

Table 5: Technical Specifications of the TP-205A

INPUTS:	Video: 1 VGA/UXGA on an 15-pin HD connector Audio: 1 audio ANALOG 3.5mm mini jack, 1 audio S/PDIF RCA connector
OUTPUTS:	1 RJ-45 OUT connector
MAX. OUTPUT LEVEL:	Video: 1V; Audio: 2.3V
RESOLUTION:	Up to UXGA
BANDWIDTH (-3dB) ² :	Audio: 20Hz – 20kHz @0.5dB
S/N RATIO:	Audio: >80dB
TOTAL GAIN:	Audio: Analog/analog: 0dB Analog/SPDIF: -12dBFS
TND+N:	Audio: <0.01%
POWER SOURCE:	12V DC 2A
DIMENSIONS:	21.46cm x 16.25cm x 4.36cm (8.45" x 6.4" x 1.72"), W, D, H
WEIGHT:	1.2kg (2.65lbs) approx.
ACCESSORIES:	Power supply
OPTIONS:	RK-1 19" rack adapter

¹ Specifications are subject to change without notice

² For the transmitter/receiver pair

LIMITED WARRANTY

Kramer Electronics (hereafter *Kramer*) warrants this product free from defects in material and workmanship under the following terms.

HOW LONG IS THE WARRANTY

Labor and parts are warranted for seven years from the date of the first customer purchase.

WHO IS PROTECTED?

Only the first purchase customer may enforce this warranty.

WHAT IS COVERED AND WHAT IS NOT COVERED

Except as below, this warranty covers all defects in material or workmanship in this product. The following are not covered by the warranty:

1. Any product which is not distributed by Kramer, or which is not purchased from an authorized Kramer dealer. If you are uncertain as to whether a dealer is authorized, please contact Kramer at one of the agents listed in the Web site www.kramerelectronics.com.
2. Any product, on which the serial number has been defaced, modified or removed, or on which the WARRANTY VOID IF TAMPERED sticker has been torn, reattached, removed or otherwise interfered with.
3. Damage, deterioration or malfunction resulting from:
 - i) Accident, misuse, abuse, neglect, fire, water, lightning or other acts of nature
 - ii) Product modification, or failure to follow instructions supplied with the product
 - iii) Repair or attempted repair by anyone not authorized by Kramer
 - iv) Any shipment of the product (claims must be presented to the carrier)
 - v) Removal or installation of the product
 - vi) Any other cause, which does not relate to a product defect
 - vii) Cartons, equipment enclosures, cables or accessories used in conjunction with the product

WHAT WE WILL PAY FOR AND WHAT WE WILL NOT PAY FOR

We will pay labor and material expenses for covered items. We will not pay for the following:

1. Removal or installations charges.
2. Costs of initial technical adjustments (set-up), including adjustment of user controls or programming. These costs are the responsibility of the Kramer dealer from whom the product was purchased.
3. Shipping charges.

HOW YOU CAN GET WARRANTY SERVICE

1. To obtain service on you product, you must take or ship it prepaid to any authorized Kramer service center.
2. Whenever warranty service is required, the original dated invoice (or a copy) must be presented as proof of warranty coverage, and should be included in any shipment of the product. Please also include in any mailing a contact name, company, address, and a description of the problem(s).
3. For the name of the nearest Kramer authorized service center, consult your authorized dealer.

LIMITATION OF IMPLIED WARRANTIES

All implied warranties, including warranties of merchantability and fitness for a particular purpose, are limited in duration to the length of this warranty.

EXCLUSION OF DAMAGES

The liability of Kramer for any effective products is limited to the repair or replacement of the product at our option. Kramer shall not be liable for:

1. Damage to other property caused by defects in this product, damages based upon inconvenience, loss of use of the product, loss of time, commercial loss; or
2. Any other damages, whether incidental, consequential or otherwise. Some countries may not allow limitations on how long an implied warranty lasts and/or do not allow the exclusion or limitation of incidental or consequential damages, so the above limitations and exclusions may not apply to you.

This warranty gives you specific legal rights, and you may also have other rights, which vary from place to place.

NOTE: All products returned to Kramer for service must have prior approval. This may be obtained from your dealer.

This equipment has been tested to determine compliance with the requirements of:

- EN-50081: "Electromagnetic compatibility (EMC);
generic emission standard.
Part 1: Residential, commercial and light industry"
- EN-50082: "Electromagnetic compatibility (EMC) generic immunity standard.
Part 1: Residential, commercial and light industry environment".
- CFR-47: FCC* Rules and Regulations:
Part 15: "Radio frequency devices
Subpart B Unintentional radiators"

CAUTION!

- Servicing the machines can only be done by an authorized Kramer technician. Any user who makes changes or modifications to the unit without the expressed approval of the manufacturer will void user authority to operate the equipment.
- Use the supplied DC power supply to feed power to the machine.
- Please use recommended interconnection cables to connect the machine to other components.

* FCC and CE approved using STP cable (for twisted pair products)



For the latest information on our products and a list of Kramer distributors, visit our Web site: www.kramerelectronics.com, where updates to this user manual may be found. We welcome your questions, comments and feedback.



Caution

Safety Warning:

Disconnect the unit from the power supply before opening/servicing.



P/N:



2900-000331

Rev:



5

Kramer Electronics, Ltd.

Web site: www.kramerelectronics.com

E-mail: info@kramerel.com

P/N: 2900-000331 REV 5