



KRAMER ELECTRONICS LTD.

USER MANUAL

MODEL:

TP-45EDID

Component/UXGA/Audio
Transmitter

P/N: 2900-300126 Rev 2



TP-45EDID Quick Start Guide

This guide helps you install and use your product for the first time. For more detailed information, go to http://www.kramerelectronics.com/support/product_downloads.asp to download the latest manual or scan the QR code on the left.

Step 1: Check what's in the box

- TP-45EDID Component/UXGA/ Audio Transmitter
- 4 Rubber feet
- 1 Power supply (12V DC)
- 1 Quick Start sheet

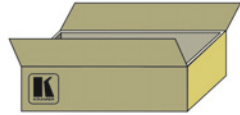

Save the original box and packaging in case your TP-45EDID needs to be returned to the factory for service.

Step 2: Install the TP-45EDID

Attach the rubber feet and place on a table or mount the machine in a rack (using an optional RK-1 rack mount).

Step 3: Connect the inputs and outputs

Always switch off the power on each device before connecting it to your TP-45EDID.

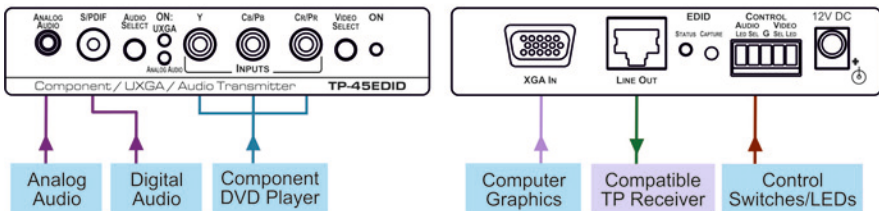

Always use Kramer high-performance cables for connecting AV equipment to the TP-45EDID.

Step 4: Connect the power

Connect the 12V DC power adapter to the TP-45EDID and plug the adapter into the mains electricity.



Step 5: Operate the TP-45EDID

Select the audio input and the video input.

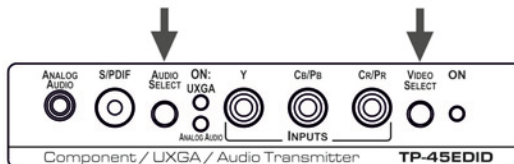

Contents

1	Introduction	1
2	Getting Started	2
2.1	Achieving the Best Performance	2
2.2	Safety Instructions	3
2.3	Recycling Kramer Products	3
3	Overview	4
3.1	Shielded Twisted Pair (STP)/Unshielded Twisted Pair (UTP)	5
3.2	About the Power Connect™ Feature	5
3.3	Defining EDID	6
4	Defining the TP-45EDID Component/UXGA/Audio Transmitter	7
5	Connecting a Component/XGA – Audio Distribution System	9
5.1	Connecting the System in XGA Mode	10
5.2	Connecting the System in Component Video Mode	11
5.3	Connecting the TP-45EDID Remote Control	13
5.4	Wiring the CAT 5 LINE IN / LINE OUT RJ-45 Connectors	14
6	Acquiring the EDID	15
7	Technical Specifications	16

Figures

Figure 1:	TP-45EDID Component/UXGA/Audio Transmitter	7
Figure 2:	Component/XGA – Audio Distribution System, XGA Mode	11
Figure 3:	Component/XGA – Audio Distribution System, Component Video Mode	13
Figure 4:	The TP-45EDID Remote Control Connection	14
Figure 5:	CAT 5 PINOUT	14

1 Introduction

Welcome to Kramer Electronics! Since 1981, Kramer Electronics has been providing a world of unique, creative, and affordable solutions to the vast range of problems that confront the video, audio, presentation, and broadcasting professional on a daily basis. In recent years, we have redesigned and upgraded most of our line, making the best even better!

Our 1,000-plus different models now appear in 11 groups that are clearly defined by function: GROUP 1: Distribution Amplifiers; GROUP 2: Switchers and Matrix Switchers; GROUP 3: Control Systems; GROUP 4: Format/Standards Converters; GROUP 5: Range Extenders and Repeaters; GROUP 6: Specialty AV Products; GROUP 7: Scan Converters and Scalers; GROUP 8: Cables and Connectors; GROUP 9: Room Connectivity; GROUP 10: Accessories and Rack Adapters and GROUP 11: Sierra Products.

Congratulations on purchasing your Kramer **TP-45EDID** *Component/UXGA/Audio Transmitter* that uses existing UTP cabling to create an efficient, fast and uncluttered environment for:

- Presentation and multimedia applications
- Long-range graphics distribution for schools, hospitals, security, and stores
- Security and military applications

2 Getting Started

We recommend that you:

- Unpack the equipment carefully and save the original box and packaging materials for possible future shipment
- Review the contents of this user manual



Go to <http://www.kramerelectronics.com> to check for up-to-date user manuals, application programs, and to check if firmware upgrades are available (where appropriate).

2.1 Achieving the Best Performance

To achieve the best performance:

- Use only good quality connection cables (we recommend Kramer high-performance, high-resolution cables) to avoid interference, deterioration in signal quality due to poor matching, and elevated noise levels (often associated with low quality cables)
- Do not secure the cables in tight bundles or roll the slack into tight coils
- Avoid interference from neighboring electrical appliances that may adversely influence signal quality
- Position your Kramer **TP-45EDID** away from moisture, excessive sunlight and dust



This equipment is to be used only inside a building. It may only be connected to other equipment that is installed inside a building.

2.2 Safety Instructions



Caution: There are no operator serviceable parts inside the unit

Warning: Use only the Kramer Electronics input power wall adapter that is provided with the unit

Warning: Disconnect the power and unplug the unit from the wall before installing

2.3 Recycling Kramer Products

The Waste Electrical and Electronic Equipment (WEEE) Directive 2002/96/EC aims to reduce the amount of WEEE sent for disposal to landfill or incineration by requiring it to be collected and recycled. To comply with the WEEE Directive, Kramer Electronics has made arrangements with the European Advanced Recycling Network (EARN) and will cover any costs of treatment, recycling and recovery of waste Kramer Electronics branded equipment on arrival at the EARN facility. For details of Kramer's recycling arrangements in your particular country go to our recycling pages at <http://www.kramerelectronics.com/support/recycling/>.

3 Overview

The **TP-45EDID** is a high-performance twisted pair transmitter for computer graphics or component video and unbalanced stereo audio signals. It converts the input signals to a twisted pair signal and transmits them over CAT 5 cable to a compatible receiver.

The **TP-45EDID** has two SELECT buttons that let you choose the video signal input (XGA or component) as well as the audio input (digital or analog signal). (The term XGA used throughout this manual implies resolutions exceeding UXGA.) By selecting the required video input signal, the **TP-45EDID** with the **TP-46N** can constitute either a component video (Y, CB/PB, CR/PR) or an XGA video – audio transmitter / receiver system:

The TP-45EDID does not convert the video signal format. Thus computer graphics sources must be routed to computer graphics outputs. Similarly, component video sources must be routed to component video outputs.

- If XGA is selected, the **TP-45EDID** receives an XGA and audio signal and transmits it over the CAT 5 cable to the XGA output on the **TP-46N** receiver
- If component video is selected, the component video signal is transmitted over the CAT 5 cable to the COMP outputs on the **TP-46N** receiver
- The analog audio or S/PDIF (digital audio)—as selected via the audio SELECT button—is transmitted together with the video signal over the CAT 5 cable to the **TP-46N** receiver
- The **TP-45EDID** can execute these control functions also remotely using simple pushbuttons (see [Section 5.3](#))

The audio signal is distributed simultaneously to the analog or digital audio outputs.

The **TP-45EDID** Component/XGA – Audio Transmitter features:

- Transmission range of more than 300ft (more than 100m)
- YUV input (also known as Y, Cb, Cr, or Y, B-Y, R-Y, or Y, Pb, Pr) on 3 RCA connectors and a computer graphics input on a 15-pin HD (F) connector
- Digital audio input (S/PDIF) on an RCA connector and a stereo analog input on a 3.5mm mini jack

- EDID capture that copies and stores the EDID from a display device
- The Power Connect™ feature where one unit can power the other over the same CAT 5 cable
- 12V DC power
- Toggling push-button selector switches and status LEDs connected by a remote selector input terminal block

3.1 Shielded Twisted Pair (STP)/Unshielded Twisted Pair (UTP)

We recommend that you use Shielded Twisted Pair (STP) cable, and stress that the compliance to electromagnetic interference was tested using STP cable. There are different levels of STP cable available, and we advise you to use the best quality STP cable that you can afford. Our non-skew-free cable, Kramer **BC-STP** is intended for analog signals where skewing is not an issue.

In cases where there is skewing, our Unshielded Twisted Pair (UTP) skew-free cable, Kramer **BC-XTP**, may be advantageous, and UTP cable might also be preferable for long range applications. In any event when using UTP cable, it is advisable to ensure that the cable is installed far away from electric cables, motors and so on, which are prone to create electrical interference.

3.2 About the Power Connect™ Feature

The Power Connect feature applies as long as the cable can carry power. This feature is available when using STP cable and the distance does not exceed 50m (164ft) on standard CAT 5 cable. For longer distances, heavy gauge cable should be used (TP cable is still suitable for the video/audio transmission, but not for feeding the power at these distances). For units which are connected via RJ-45 connectors, make sure that the shield of the STP cable is connected to the metal casing of the connectors on both ends of the cable. For units which are connected via terminal block connectors, the shield of the STP cable must be connected to a ground terminal on the units at both ends (use the ground terminal of the power supply connection if necessary).

For a TP cable exceeding a distance of 50m, separate power supplies should be connected to the transmitter and to the receiver simultaneously.

3.3 Defining EDID

The Extended Display Identification Data (EDID) is a data-structure provided by a display, to describe its capabilities to a graphics card (that is connected to the display's source). The EDID enables the **TP-45EDID** to "know" what kind of monitor is connected to the output. The EDID includes the manufacturer's name, the product type, the timing data supported by the display, the display size, luminance data and (for digital displays only) the pixel mapping data. EDID is defined by a standard published by the Video Electronics Standards Association (VESA).

4 Defining the TP-45EDID Component/UXGA/Audio Transmitter

This section defines the **TP-45EDID**.

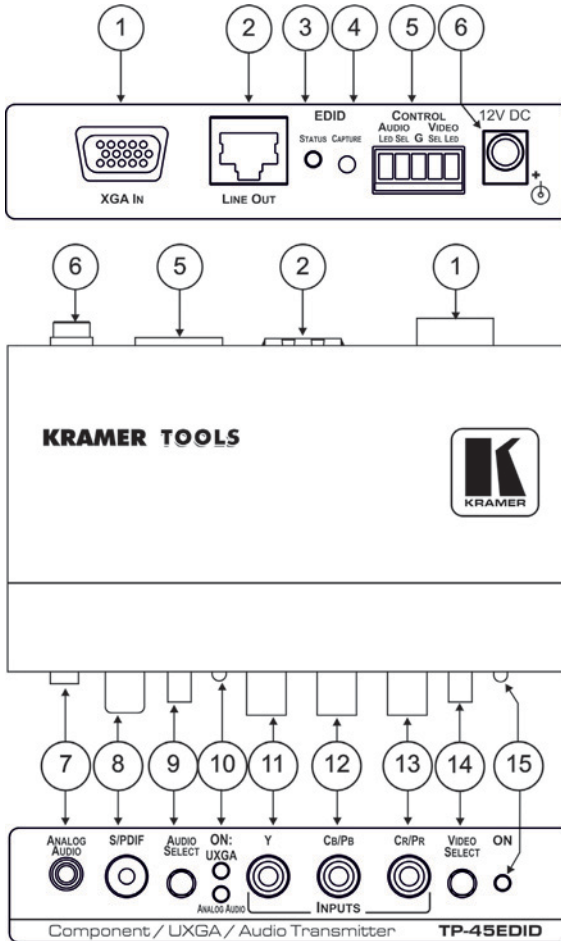

Figure 1: TP-45EDID Component/UXGA/Audio Transmitter

#	Feature		Function
1	XGA IN 15-pin HD (F) Connector		Connect to the XGA source
2	LINE OUT RJ-45 Connector		Connect to the LINE IN connector of the receiver
3	EDID Status LED		Illuminates during normal operation; flashes when acquiring the EDID
4	EDID CAPTURE Button		Press to acquire the EDID information from the display
5	CONTROL AUDIO/VIDEO Terminal Block		Connect to remote push-button switches and status LEDs
6	12V DC		+12V DC connector for powering the unit
7	ANALOG AUDIO 3.5mm Mini Connector		Connect to the stereo analog audio source
8	S/PDIF RCA Connector		Connect to the digital audio source
9	AUDIO SELECT Button	ANALOG AUDIO	Press to toggle between analog audio and digital S/PDIF audio
		S/PDIF	
10	ON LEDES	UXGA	Lights when computer graphics video is selected
		ANALOG AUDIO	Lights when analog audio is selected
11	INPUTS	Y RCA Connector	Connect to the component video source
12		CB/PB RCA Connector	
13		CR/PR RCA Connector	
14	VIDEO SELECT Input Button		Press to toggle between component video and computer graphics video
15	ON LED		Lights when receiving power

5 Connecting a Component/XGA – Audio Distribution System

The Component/XGA – Audio Distribution System can be configured to operate in one of two **video** modes:

- In the XGA mode, a computer graphics source is connected to the input and transmitted to a display connected to the receiver (see [Section 5.1](#))
- In the component video mode, a component video source is connected to the input and transmitted to a TV set connected to the receiver (see [Section 5.2](#))

The Component/XGA – Audio Distribution System can be configured to operate in one of two **audio** modes:

- In the analog mode, an analog audio source is connected to the input and transmitted to an acceptor connected to the receiver (see [Section 5.1](#))
- In the digital audio mode, an S/PDIF audio source is connected to the input and transmitted to a digital acceptor connected to the receiver (see [Section 5.2](#))

Thus, there are four possible system configurations: computer graphics/analog audio, computer graphics/digital audio, component video/analog audio, and component video/digital audio.

The modes of the system are determined by setting the VIDEO SELECT and AUDIO SELECT switches on the **TP-45EDID**. Whatever modes are set at the transmitter the video and audio signals are sent to the receiver and any additional cascaded receivers.

There is no signal conversion; a component input cannot be sent to a computer graphics output, nor can a digital audio input be sent to an analog audio output.

5.1 Connecting the System in XGA Mode

To configure a **TP-45EDID** and **TP-46N** Component/XGA – Audio distribution system (using up to 300ft (100m) of UTP cabling) in the XGA mode, as illustrated in the example in [Figure 2](#), do the following:

1. On the **TP-45EDID**, connect the following:
 - An XGA source (for example, the graphics card on a laptop) to the XGA 15-pin HD (F) connector
 - An analog audio source to the ANALOG AUDIO 3.5mm mini jack (or a digital audio source to the S/PDIF RCA connector), for example, using a Kramer C-GMA/GMA cable (VGA 15-pin HD (M) with audio jack to VGA 15-pin HD (M) with audio jack)
2. On the **TP-45EDID**, use the SELECT buttons as follows:
 - Momentarily press the video SELECT button. The UXGA LED lights when the UXGA input is selected
 - Momentarily press the AUDIO SELECT button to toggle between the S/PDIF and analog audio inputs
3. On the **TP-46N**, connect the following:
 - The XGA OUT 15-pin HD (F) connector to the XGA acceptor (for example, a display)
 - The ANALOG AUDIO 3.5mm mini jack to the analog audio acceptor (for example, powered speakers)
4. Connect the LINE OUTPUT RJ-45 connector on the **TP-45EDID** to the LINE IN RJ-45 connector on the **TP-46N**, via CAT 5 cabling, see [Figure 5](#).
5. Connect the 12V DC power adapter to the power socket and connect the adapter to the mains electricity on both the **TP-45EDID** and the **TP-46N** (not shown).

The signal from the XGA source is transmitted via CAT 5 cable, decoded and converted at the XGA OUT 15-pin HD (F) connector to the XGA acceptor.
6. If required, connect the LINE OUT RJ-45 connector on the **TP-46N** to an additional **TP-46N**.

7. On the **TP-46N** underside:

- Using a screwdriver to carefully rotate the trimmer, adjust the video output signal level and/or cable compensation equalization level, if required

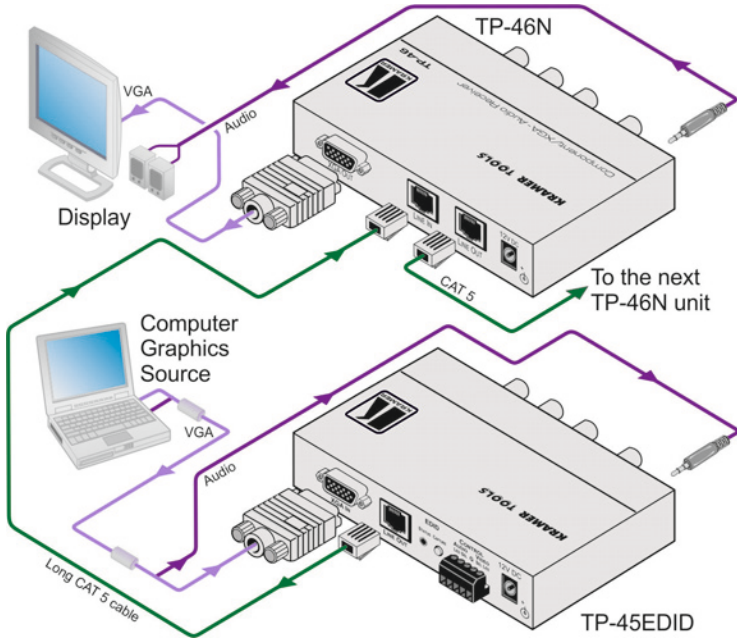

Figure 2: Component/XGA – Audio Distribution System, XGA Mode

5.2 Connecting the System in Component Video Mode

To configure a **TP-45EDID/TP-46N** Component/XGA – Audio distribution system in the component video mode, as the example in [Figure 3](#) illustrates, do the following:

1. On the **TP-45EDID**, connect the following:
 - A component video source (for example, a DVD player) to the Y, Cb/Pb, Cr/Pr RCA connectors
 - A digital audio source to the S/PDIF RCA connector using up to 300ft (100m) of UTP cabling

2. On the **TP-45EDID**, use the SELECT buttons as follows:
 - Momentarily press the VIDEO SELECT button. The UXGA LED turns off when the component video input is selected
 - Momentarily press the AUDIO SELECT button to toggle between the S/PDIF and analog audio inputs
3. On the **TP-46N**, connect the following:
 - The Y, CB/PB, CR/PR RCA connectors to a component video acceptor (for example, a plasma display)
 - The S/PDIF RCA connector to the digital audio acceptor (for example, the audio input on the plasma display)
4. Connect the LINE OUTPUT RJ-45 connector on the **TP-45EDID** to the LINE IN RJ-45 connector on the **TP-46N**, via CAT 5 cabling, see [Figure 5](#).
5. Connect the 12V DC power adapter to the power socket and connect the adapter to the mains electricity on both the **TP-45EDID** and the **TP-46N** (not shown in [Figure 3](#)).

The signal from the component video source is transmitted via the CAT 5 cable; decoded and converted to component video and outputted on the Y, CB/PB, CR/PR OUTPUTS RCA connectors to the component video acceptor.
6. Connect the LINE OUT RJ-45 connector on the **TP-46N** to a second **TP-46N** unit (optional).
7. If required, connect the LINE OUT RJ-45 connector on the **TP-46N** to additional **TP-46N** units.

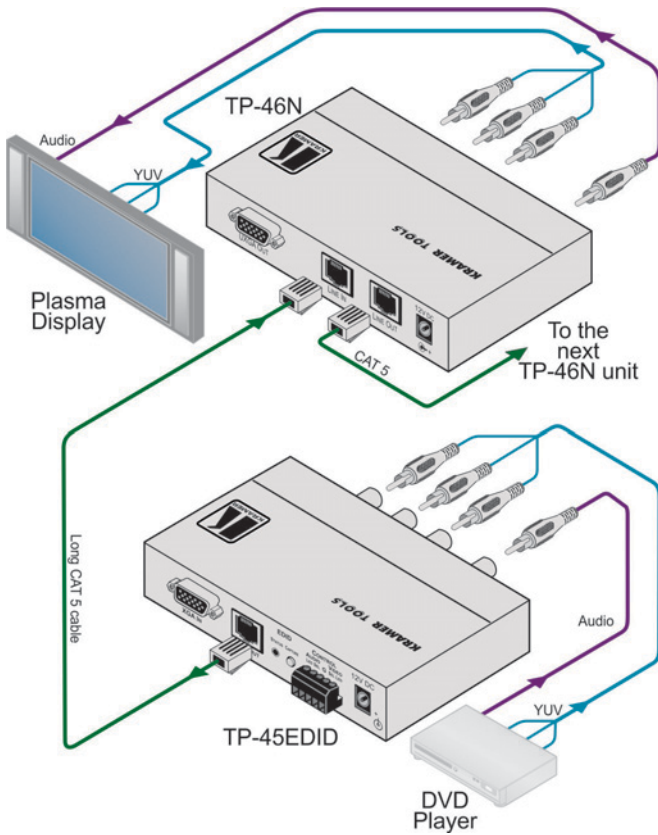

Figure 3: Component/XGA – Audio Distribution System, Component Video Mode

5.3 Connecting the TP-45EDID Remote Control

Connect momentary push-buttons and LEDs (each LED is driven by a 5V source and a 392Ω series resistor) to a cable and attach the cable to a 5-pin terminal block for connection to the **TP-45EDID** control port as shown in [Figure 4](#).

Each press of the selector button toggles the audio or video system mode and turns on or off the remote and panel status LEDs according to the active mode.

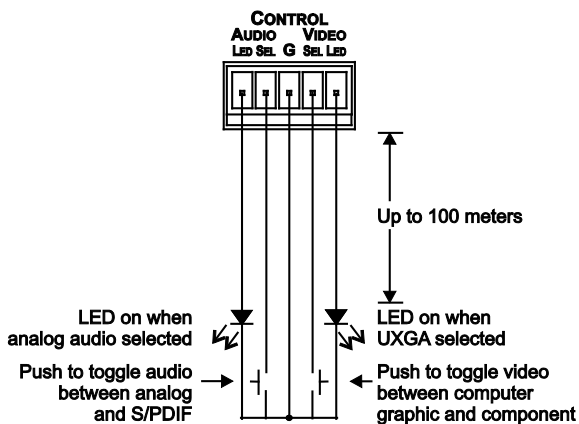

Figure 4: The TP-45EDID Remote Control Connection

5.4 Wiring the CAT 5 LINE IN / LINE OUT RJ-45 Connectors

This section defines the CAT 5 pinout, using a straight pin-to-pin cable with RJ-45 connectors.



Note, that the cable Ground shielding must be connected / soldered to the connector shield.

EIA /TIA 568B	
PIN	Wire Color
1	Orange / White
2	Orange
3	Green / White
4	Blue
5	Blue / White
6	Green
7	Brown / White
8	Brown
Pair 1	4 and 5
Pair 2	1 and 2
Pair 3	3 and 6
Pair 4	7 and 8

Figure 5: CAT 5 PINOUT

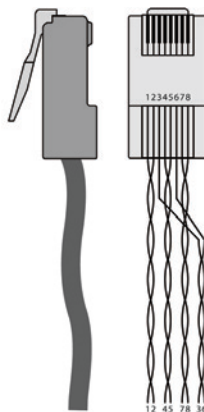

6 Acquiring the EDID

The transmitter can acquire the EDID information from the display connected to the transmitter or acquire the default EDID.

To acquire the display EDID, do the following:

1. Connect the XGA INPUT 15-pin HD connector to the input XGA connector of the display, using a short cable.
The EDID is carried over pins 12 and 15 of the VGA connector. It is essential that the cable used for capturing the EDID passes all 15 pins
2. Connect power to the display.
3. On the transmitter, connect the 12V DC power adapter to the power socket and connect the adapter to the mains electricity.
4. Press the EDID CAPTURE button.
5. Once the EDID STATUS LED flashes slowly several times, the EDID is captured.
6. Disconnect the display.

To acquire the default EDID:

Do not connect the display to the transmitter when acquiring the default EDID.

1. On the transmitter, connect the 12V DC power adapter to the power socket and connect the adapter to the mains electricity.
2. Press the EDID CAPTURE button.
3. Once the EDID STATUS flashes rapidly several times, the default EDID is captured.

Alternatively, you can press the EDID CAPTURE button after connecting the transmitter receiver system. When the EDID STATUS LED flashes rapidly several times, the default EDID information is acquired.

7 Technical Specifications

INPUTS:	Video: 1 component 1Vpp/75Ω (Y,Pb,Pr) on 3 RCA connectors, 1 XGA on a 15-pin HD connector; Audio: 1 unbalanced stereo audio, 0dBu/50kΩ, on a 3.5mm jack; 1 S/PDIF audio on an RCA connector
OUTPUT:	1 CAT 5 on an RJ-45 connector (video/audio)
MAX. INPUT LEVEL:	XGA: 1.7Vpp on 75Ω, DC coupling; Y,Pb,Pr: 1.05Vpp on 75Ω, AC coupling
RETURN LOSS:	-18dB
VIDEO RESOLUTION:	Up to UXGA, 1080p
*S/N RATIO:	69dB RMS @5MHz
*K-FACTOR:	0.2%
*ISOLATION (CROSSTALK):	-43dB @ 5MHz
*AUDIO BANDWIDTH:	20Hz to 20kHz
*TND+NOISE:	0.33% @ 1kHz
SAMPLE RATE CONVERSION:	48kHz
RESOLUTION CONVERSION:	24 bits
OPERATING TEMPERATURE:	0° to +40°C (32° to 104°F)
STORAGE TEMPERATURE:	-40° to +70°C (-40° to 158°F)
HUMIDITY:	10% to 90%, RHL non-condensing
POWER SOURCE:	12V DC, 920mA max. (TP-46N, TP-45EDID pair when powered from the TP-45EDID via power connect, CAT 5, 60m); TP-45EDID self current:110mA
DIMENSIONS:	12cm x 7.15cm x 2.76cm (4.7" x 2.81" 1.09") W, D, H
WEIGHT:	0.3 kg (0.67 lbs) approx
ACCESSORIES:	Power supply
Specifications are subject to change without notice at http://www.kramerelectronics.com	

* Starred specifications are measured using a **TP-45EDID** and **TP-46N** pair unless otherwise stated.

LIMITED WARRANTY

The warranty obligations of Kramer Electronics for this product are limited to the terms set forth below:

What is Covered

This limited warranty covers defects in materials and workmanship in this product.

What is Not Covered

This limited warranty does not cover any damage, deterioration or malfunction resulting from any alteration, modification, improper or unreasonable use or maintenance, misuse, abuse, accident, neglect, exposure to excess moisture, fire, improper packing and shipping (such claims must be presented to the carrier), lightning, power surges, or other acts of nature. This limited warranty does not cover any damage, deterioration or malfunction resulting from the installation or removal of this product from any installation, any unauthorized tampering with this product, any repairs attempted by anyone unauthorized by Kramer Electronics to make such repairs, or any other cause which does not relate directly to a defect in materials and/or workmanship of this product. This limited warranty does not cover cartons, equipment enclosures, cables or accessories used in conjunction with this product.

Without limiting any other exclusion herein, Kramer Electronics does not warrant that the product covered hereby, including, without limitation, the technology and/or integrated circuit(s) included in the product, will not become obsolete or that such items are or will remain compatible with any other product or technology with which the product may be used.

How Long Does this Coverage Last

Seven years as of this printing; please check our Web site for the most current and accurate warranty information.

Who is Covered

Only the original purchaser of this product is covered under this limited warranty. This limited warranty is not transferable to subsequent purchasers or owners of this product.

What Kramer Electronics will do

Kramer Electronics will, at its sole option, provide one of the following three remedies to whatever extent it shall deem necessary to satisfy a proper claim under this limited warranty:

1. Elect to repair or facilitate the repair of any defective parts within a reasonable period of time, free of any charge for the necessary parts and labor to complete the repair and restore this product to its proper operating condition. Kramer Electronics will also pay the shipping costs necessary to return this product once the repair is complete.
2. Replace this product with a direct replacement or with a similar product deemed by Kramer Electronics to perform substantially the same function as the original product.
3. Issue a refund of the original purchase price less depreciation to be determined based on the age of the product at the time remedy is sought under this limited warranty.

What Kramer Electronics will not do Under This Limited Warranty

If this product is returned to Kramer Electronics or the authorized dealer from which it was purchased or any other party authorized to repair Kramer Electronics products, this product must be insured during shipment, with the insurance and shipping charges prepaid by you. If this product is returned uninsured, you assume all risks of loss or damage during shipment. Kramer Electronics will not be responsible for any costs related to the removal or re-installation of this product from or into any installation. Kramer Electronics will not be responsible for any costs related to any setting up this product, any adjustment of user controls or any programming required for a specific installation of this product.

How to Obtain a Remedy under this Limited Warranty

To obtain a remedy under this limited warranty, you must contact either the authorized Kramer Electronics reseller from whom you purchased this product or the Kramer Electronics office nearest you. For a list of authorized Kramer Electronics resellers and/or Kramer Electronics authorized service providers, please visit our web site at www.kramerelectronics.com or contact the Kramer Electronics office nearest you.

In order to pursue any remedy under this limited warranty, you must possess an original, dated receipt as proof of purchase from an authorized Kramer Electronics reseller. If this product is returned under this limited warranty, a return authorization number, obtained from Kramer Electronics, will be required. You may also be directed to an authorized reseller or a person authorized by Kramer Electronics to repair the product.

If it is decided that this product should be returned directly to Kramer Electronics, this product should be properly packed, preferably in the original carton, for shipping. Cartons not bearing a return authorization number will be refused.

Limitation on Liability

THE MAXIMUM LIABILITY OF KRAMER ELECTRONICS UNDER THIS LIMITED WARRANTY SHALL NOT EXCEED THE ACTUAL PURCHASE PRICE PAID FOR THE PRODUCT. TO THE MAXIMUM EXTENT PERMITTED BY LAW, KRAMER ELECTRONICS IS NOT RESPONSIBLE FOR DIRECT, SPECIAL, INCIDENTAL OR CONSEQUENTIAL DAMAGES RESULTING FROM ANY BREACH OF WARRANTY OR CONDITION, OR UNDER ANY OTHER LEGAL THEORY. Some countries, districts or states do not allow the exclusion or limitation of relief, special, incidental, consequential or indirect damages, or the limitation of liability to specified amounts, so the above limitations or exclusions may not apply to you.

Exclusive Remedy

TO THE MAXIMUM EXTENT PERMITTED BY LAW, THIS LIMITED WARRANTY AND THE REMEDIES SET FORTH ABOVE ARE EXCLUSIVE AND IN LIEU OF ALL OTHER WARRANTIES, REMEDIES AND CONDITIONS, WHETHER ORAL OR WRITTEN, EXPRESS OR IMPLIED. TO THE MAXIMUM EXTENT PERMITTED BY LAW, KRAMER ELECTRONICS SPECIFICALLY DISCLAIMS ANY AND ALL IMPLIED WARRANTIES, INCLUDING, WITHOUT LIMITATION, WARRANTIES OF MERCHANTABILITY AND FITNESS FOR A PARTICULAR PURPOSE. IF KRAMER ELECTRONICS CANNOT LAWFULLY DISCLAIM OR EXCLUDE IMPLIED WARRANTIES UNDER APPLICABLE LAW, THEN ALL IMPLIED WARRANTIES COVERING THIS PRODUCT, INCLUDING WARRANTIES OF MERCHANTABILITY AND FITNESS FOR A PARTICULAR PURPOSE, SHALL APPLY TO THIS PRODUCT AS PROVIDED UNDER APPLICABLE LAW.

IF ANY PRODUCT TO WHICH THIS LIMITED WARRANTY APPLIES IS A "CONSUMER PRODUCT" UNDER THE MAGNUSON-MOSS WARRANTY ACT (15 U.S.C.A. §2301, ET SEQ.) OR OTHER APPLICABLE LAW, THE FOREGOING DISCLAIMER OF IMPLIED WARRANTIES SHALL NOT APPLY TO YOU, AND ALL IMPLIED WARRANTIES ON THIS PRODUCT, INCLUDING WARRANTIES OF MERCHANTABILITY AND FITNESS FOR THE PARTICULAR PURPOSE, SHALL APPLY AS PROVIDED UNDER APPLICABLE LAW.

Other Conditions

This limited warranty gives you specific legal rights, and you may have other rights which vary from country to country or state to state.

This limited warranty is void if (i) the label bearing the serial number of this product has been removed or defaced, (ii) the product is not distributed by Kramer Electronics or (iii) this product is not purchased from an authorized Kramer Electronics reseller. If you are unsure whether a reseller is an authorized Kramer Electronics reseller, please visit our Web site at www.kramerelectronics.com or contact a Kramer Electronics office from the list at the end of this document.

Your rights under this limited warranty are not diminished if you do not complete and return the product registration form or complete and submit the online product registration form. Kramer Electronics thanks you for purchasing a Kramer Electronics product. We hope it will give you years of satisfaction.



For the latest information on our products and a list of Kramer distributors, visit our Web site where updates to this user manual may be found.

We welcome your questions, comments, and feedback.

Web site: www.kramerelectronics.com

E-mail: info@kramerel.com



SAFETY WARNING

Disconnect the unit from the power supply before opening and servicing



P/N: 2900-300126



Rev: 2