



KRAMER ELECTRONICS LTD.

USER MANUAL

MODEL:

VP-1608

16x8 RGBHV/Balanced Audio
Matrix

P/N: 2900-001608 Rev 5

VP-1608 Quick Start Guide

This page guides you through a basic installation and first-time use of your **VP-1608**. For more detailed information, see the **VP-1608** User Manual. You can download the latest manual at <http://www.kramerelectronics.com>.

Step 1: Check what's in the box

- VP-1608** 16x8 RGBHV/
Balanced Audio Matrix
- 1 Power cord
- 1 Set of rack "ears"
- 4 Rubber feet
- 1 User Manual
- Windows®-based Kramer control software
- Kramer **RC-IR3** Infrared Remote Control
Transmitter with batteries and user manual
- 1 Quick Start sheet

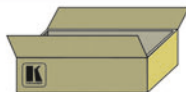

Save the original box and packaging in case your **VP-1608** needs to be returned to the factory for service.

Step 2: Install the VP-1608

Mount the machine in a rack (using the included rack "ears") or place on a table.

Step 3: Connect the inputs and outputs

Always switch off the power on each device before connecting it to your **VP-1608**.

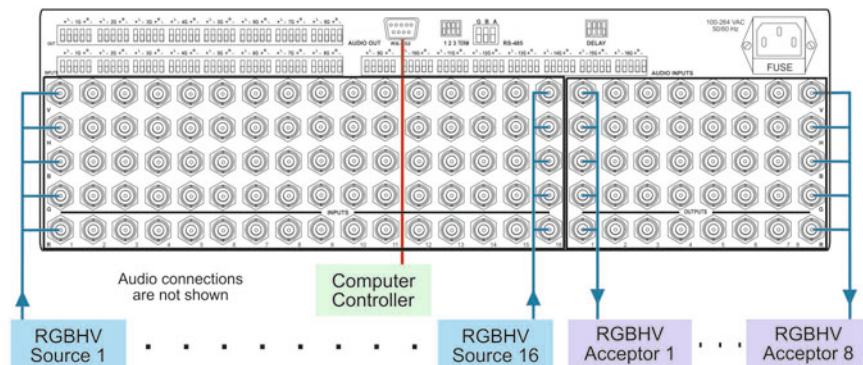

Always use Kramer high-performance cables for connecting AV equipment to the **VP-1608**.

Step 4: Connect the power

Connect the power cord to the **VP-1608** and plug it into the mains electricity.



Step 5: Operate the VP-1608

Operate from the front panel buttons, IR remote control or an RS-232 or RS-485 controller.

Contents

1	Introduction	1
2	Getting Started	2
2.1	Achieving the Best Performance	2
3	Overview	3
3.1	Defining the VP-1608 16x8 RGBHV/Balanced Audio Matrix	3
4	Installing in a Rack	8
5	Connecting a Single VP-1608	9
5.1	Connecting a Balanced/Unbalanced Stereo Audio Input/Output	11
5.2	Connecting to the VP-1608 via RS-232	11
5.3	Connecting a PC or Controller to the RS-485 Port	11
5.4	Setting the MACHINE # DIP-Switches	12
5.5	Setting the DELAY DIP-Switches	13
6	Connecting Multiple VP-1608 Units	14
6.1	Connecting via a PC or Serial Controller	14
6.2	Connecting via an RS-485 Controller	15
7	Operating Your VP-1608 16x8 RGBHV/Balanced Audio Matrix	17
7.1	Using the Audio-Follow-Video or Breakaway Option	17
7.2	Switching OUT-IN Combinations	18
7.3	Confirming Settings	19
7.4	Storing/Recalling Input/Output Configurations	20
7.5	Adjusting the Audio Gain Control	22
7.6	Locking and Unlocking the Front Panel	22
7.7	Resetting the VP-1608 16x8 RGBHV/Balanced Audio Matrix	22
7.8	Displaying Unit Characteristics	23
8	Flash Memory Upgrade	24
8.1	Downloading from the Internet	24
8.2	Connecting the PC to the RS-232 Port	24
8.3	Upgrading the Firmware	25
9	Technical Specifications	30
10	Table of Hex Codes for Serial Communication	31
11	Hex Tables for Audio Input/Output Gain Control	33
11.1	Hex Tables for Audio Input Gain Control	33
11.2	Hex Tables for Audio Output Gain Control	35
12	Kramer Protocol 2000	37

Figures

Figure 1: VP-1608 16x8 RGBHV/Balanced Audio Matrix Front Panel	4
Figure 2: VP-1608 16x8 RGBHV/Balanced Audio Matrix Rear Panel	6
Figure 3: VP-1608 Underside Flash Program Switches	7
Figure 4: Connecting the VP-1608	10
Figure 5: Balanced Stereo Audio Connection	11
Figure 6: Unbalanced Stereo Audio Input Connection	11
Figure 7: Unbalanced Stereo Audio Output Connection	11
Figure 8: Control Configuration via RS-232 and RS-485	15
Figure 9: DIP-Switch Setup on a Single Machine	17
Figure 10: VP-1608 Unit Characteristics	23
Figure 11: VP-1608 Underside Flash Program Switches Set for Upgrade	25
Figure 12: Splash Screen	25
Figure 13: Atmel – Flip Window	26
Figure 14: Device Selection Window	26
Figure 15: Device Selection Window	27
Figure 16: Loading the Hex	27
Figure 17: RS-232 Window	28
Figure 18: Atmel – Flip Window (Connected)	28
Figure 19: Atmel – Flip Window (Operation Completed)	29

1 Introduction

Welcome to Kramer Electronics! Since 1981, Kramer Electronics has been providing a world of unique, creative, and affordable solutions to the vast range of problems that confront the video, audio, presentation, and broadcasting professional on a daily basis. In recent years, we have redesigned and upgraded most of our line, making the best even better!

Our 1,000-plus different models now appear in 11 groups that are clearly defined by function: GROUP 1: Distribution Amplifiers; GROUP 2: Switchers and Matrix Switchers; GROUP 3: Control Systems; GROUP 4: Format/Standards Converters; GROUP 5: Range Extenders and Repeaters; GROUP 6: Specialty AV Products; GROUP 7: Scan Converters and Scalers; GROUP 8: Cables and Connectors; GROUP 9: Room Connectivity; GROUP 10: Accessories and Rack Adapters and GROUP 11: Sierra Products.

Congratulations on purchasing your Kramer **VP-1608** *16x8 RGBHV/Balanced Audio Matrix*, which is ideal for the following typical applications:

- Any professional system requiring outstanding value in a 16x8 matrix
- Production and duplications facilities

2 Getting Started

We recommend that you:

- Unpack the equipment carefully and save the original box and packaging materials for possible future shipment
- Review the contents of this user manual
- Use Kramer high-performance, high-resolution cables
- Use only the power cord that is supplied with this machine



Go to <http://www.kramerelectronics.com> to check for up-to-date user manuals, application programs, and to check if firmware upgrades are available (where appropriate).

2.1 Achieving the Best Performance

To achieve the best performance:

- Use only good quality connection cables to avoid interference, deterioration in signal quality due to poor matching, and elevated noise levels (often associated with low quality cables)
- Do not secure the cables in tight bundles or roll the slack into tight coils
- Avoid interference from neighboring electrical appliances that may adversely influence signal quality
- Position your Kramer **VP-1608** away from moisture, excessive sunlight and dust

3 Overview

The **VP-1608** *16x8 RGBHV/Balanced Audio Matrix* is a true matrix switcher, routing any input to any or all outputs. The **VP-1608** includes 16 input and 8 output selector buttons.

The unit features:

- A bandwidth of 400MHz (fully loaded) for RGB signals
- A unique vertical and horizontal sync-pulse solution
- Audio-follow-video or audio breakaway option (to switch audio independently from video)
- 15 preset memory locations for quick access to common configurations
- A “TAKE” button for precise switch control, letting you place multiple switches in a queue, and then activate them, with one touch of this button or a single serial command
- A delayed switching mode (ranging from 0 to 3.5sec in increments of 0.5sec), for clean transitions when switching between non-genlocked sources

Control the **VP-1608** using the front panel buttons, or remotely via:

- RS-485 or RS-232 serial commands—that also support audio gain adjustments for each input and output—transmitted by a touch screen system, PC, or other serial controller
- The Kramer **RC-IR3** Infrared Remote Control Transmitter

The **VP-1608** is dependable, rugged and fits into three vertical spaces (3U) of a standard 19" rack.

3.1 Defining the VP-1608 16x8 RGBHV/Balanced Audio Matrix

[Figure 1](#) and [Figure 2](#) define the front and rear panels of the **VP-1608**. [Figure 3](#) defines the switches on the underside.

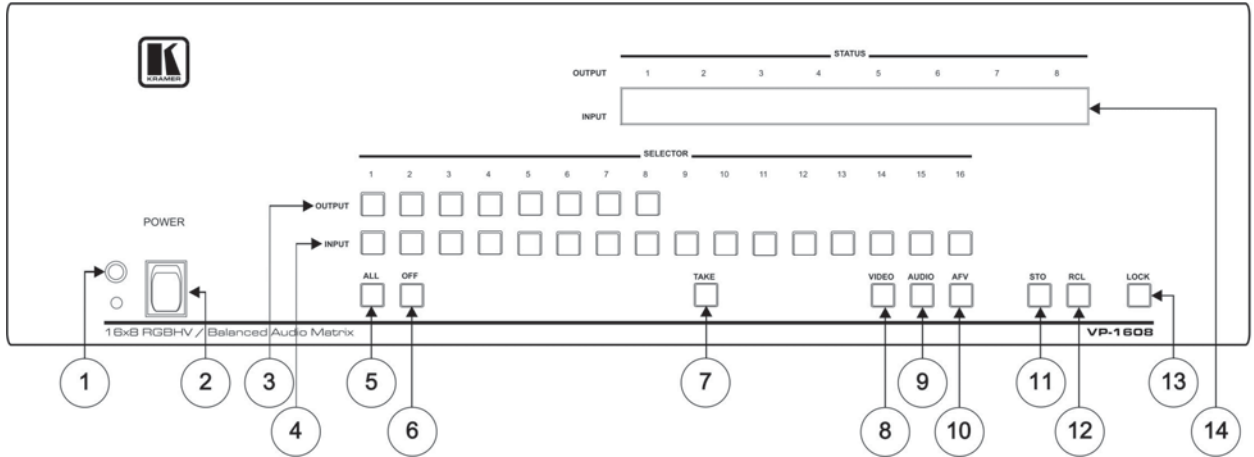

Figure 1: VP-1608 16x8 RGBHV/Balanced Audio Matrix Front Panel

#	Feature	Function
1	IR Receiver	The LED is illuminated when receiving signals from the Kramer Infra-red remote control transmitter
2	POWER Switch	Illuminated switch supplying power to the unit
3	OUTPUT SELECTOR Buttons	Select the output to which the input is switched (from 1 to 8)
4	INPUT SELECTOR Buttons	Select the input to switch to the output (from 1 to 16) Use the INPUT SELECTOR buttons to store/recall the input/output configurations (refer to Section 7.4)
5	ALL Button	Pressing ALL followed by an INPUT button, connects that input to all outputs For example, press ALL and then INPUT button # 2 to connect input # 2 to all the outputs
6	OFF Button	Pressing OFF after pressing an OUTPUT button disconnects that output from the inputs. To disconnect all the outputs, press the ALL button and then the OFF button
7	TAKE Button	Pressing TAKE toggles the mode between the CONFIRM mode and the AT ONCE mode (user confirmation per action is unnecessary)
8	VIDEO Button	When pressed actions relate to video
9	AUDIO Button	When pressed actions relate to audio
10	AFV Button	When pressed audio channels follow the video channels. The button is illuminated when the AFV mode is selected
11	STO Button	Pressing STO (STORE) followed by an input button stores the current setup
12	RCL Button	Pressing the RCL (RECALL) button and the corresponding input button recalls a setup After pressing the button, the stored status flashes. Pressing a different input button lets you view (only view, nothing is implemented at this stage) another setup. After making your choice, pressing the RCL button again implements the new status
13	LOCK Button	Pressing the LOCK button for more than 2 seconds, engages/disengages the front panel switches
14	INPUT STATUS 7-segment Display	Displays the selected input switched to the output (marked above each input) Also displays the number included in the product name and the firmware version number, as Section 7.8 describes

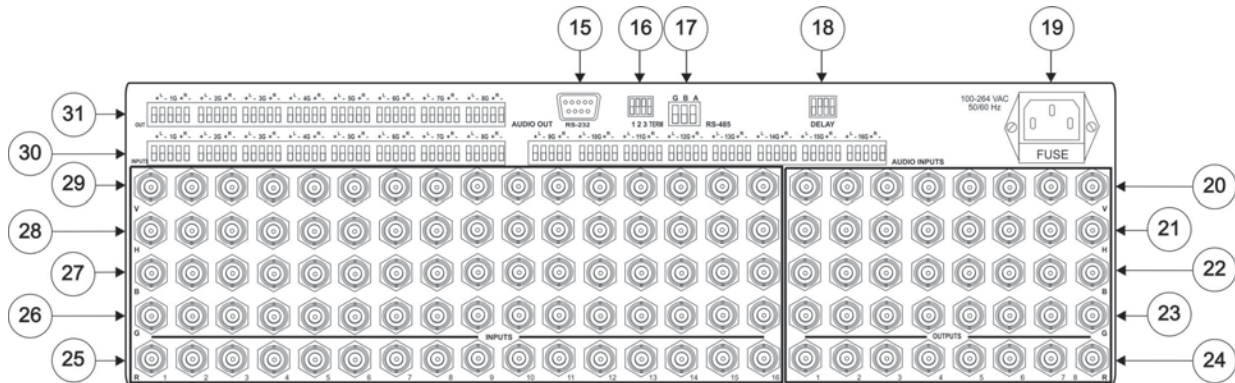

Figure 2: VP-1608 16x8 RGBHV/Balanced Audio Matrix Rear Panel

#	Feature	Function
15	RS-232 9-pin D-sub (F) Connector	Connects to the PC or other Serial Controller
16	Setup DIP-switches	DIPS 1, 2, and 3 for setup of the Machine #; DIP 4 for RS-485 termination
17	RS-485 Connector	RS-485 port on detachable terminal block
18	DELAY DIP-switches	DIP-switches for setup of the delay time ranging from 0sec to 3.5sec (in increments of 0.5sec)
19	Power Connector with Fuse	AC connector enabling power supply to the unit
20	Video Outputs	V (Vertical Sync) OUTPUT BNC Connectors
21		H (Horizontal Sync) OUTPUT BNC Connectors
22		B OUTPUT BNC Connectors
23		G OUTPUT BNC Connectors
24		R OUTPUT BNC Connectors
		Connect to the RGBHV video acceptors (1 to 8) For RGBS applications, one of the sync channels (H or V) may be used for the S channel

#	Feature	Function
25	Video Inputs	R INPUT BNC Connectors
26		G INPUT BNC Connectors
27		B INPUT BNC Connectors
28		H (Horizontal Sync) INPUT BNC Connectors
29		V (Vertical Sync) INPUT BNC Connectors
30	AUDIO INPUTS Terminal Block Connectors	Connect to the audio sources (from 1 to 16)
31	AUDIO OUT Terminal Block Connectors	Connect to the audio acceptors (from 1 to 8)

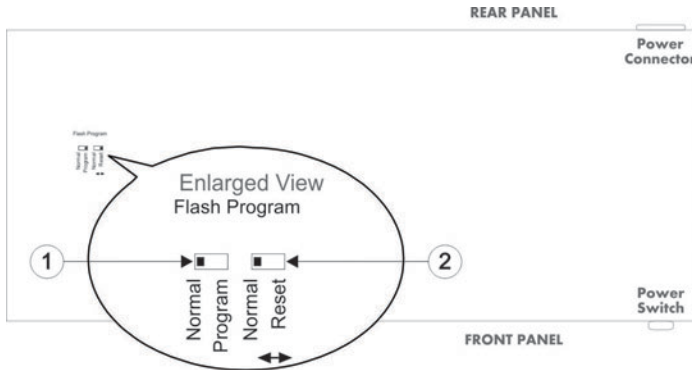

Figure 3: VP-1608 Underside Flash Program Switches

#	Feature	Function
1	Flash Program Switch 1	Slide right for Program (to upgrade firmware see Section 8), or left for Normal (factory default)
2	Flash Program Switch 2	Slide right for Reset (to upgrade firmware see Section 8), or left for Normal (factory default)

4 Installing in a Rack

This section provides instructions for rack mounting the unit.

Before installing in a rack, be sure that the environment is within the recommended range:

OPERATING TEMPERATURE:	0° to +55°C (32° to 131°F)
STORAGE TEMPERATURE:	-45° to +72°C (-49° to 162°F)
HUMIDITY:	10% to 90%, RHL non-condensing



CAUTION!

When installing on a 19" rack, avoid hazards by taking care that:

1. It is located within the recommended environmental conditions, as the operating ambient temperature of a closed or multi unit rack assembly may exceed the room ambient temperature.
2. Once rack mounted, enough air will still flow around the machine.
3. The machine is placed straight in the correct horizontal position.
4. You do not overload the circuit(s). When connecting the machine to the supply circuit, overloading the circuits might have a detrimental effect on overcurrent protection and supply wiring. Refer to the appropriate nameplate ratings for information. For example, for fuse replacement, see the value printed on the product label.
5. The machine is earthed (grounded) in a reliable way and is connected only to an electricity socket with grounding. Pay particular attention to situations where electricity is supplied indirectly (when the power cord is not plugged directly into the socket in the wall), for example, when using an extension cable or a power strip, and that you use only the power cord that is supplied with the machine.

To rack-mount a machine:

1. Attach both ear brackets to the machine. To do so, remove the screws from each side of the machine (5 on each side), and replace those screws through the ear brackets.

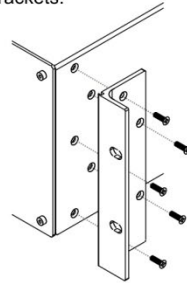

2. Place the ears of the machine against the rack rails, and insert the proper screws (not provided) through each of the four holes in the rack ears.

Note:

- In some models, the front panel may feature built-in rack ears
- Detachable rack ears can be removed for desktop use
- Always mount the machine in the rack before you attach any cables or connect the machine to the power
- If you are using a Kramer rack adapter kit (for a machine that is not 19"), see the Rack Adapters user manual for installation instructions available from our Web site

5 Connecting a Single VP-1608



Always switch off the power to each device before connecting it to your **VP-1608**. After connecting your **VP-1608**, connect its power and then switch on the power to each device.

To connect a single **VP-1608** 16x8 RGBHV/Balanced Audio Matrix as illustrated in [Figure 4](#), do the following:

To connect up to 8 **VP-1608** units to a PC or other RS-232/RS-485 controller (see [Section 6](#)).

1. Connect up to 16 RGBHV sources (such as RGBHV graphics sources) to the RGBHV INPUT BNC connectors.
Not all sources or acceptors need to be connected.
2. Connect up to 8 RGBHV acceptors (such as RGBHV projectors) to the RGBHV OUTPUT BNC connectors.
3. Connect up to 16 stereo audio sources to the AUDIO INPUT terminal block connectors (see [Section 5.1](#)).
4. Connect up to 8 stereo audio acceptors to the AUDIO OUTPUT terminal block connectors (see [Section 5.1](#)).
5. Set the MACHINE # DIP-switches to MACHINE # 1, according to [Figure 9](#), that is, set all switches OFF (see [Section 5.3](#)).
6. Set the DELAY DIP-switches, if required (see [Section 5.5](#)).
7. Connect a PC or other controller, if required, via the RS-232 (see [Section 5.2](#)) or RS-485 ports (see [Section 5.3](#)).
8. Connect the power cord.

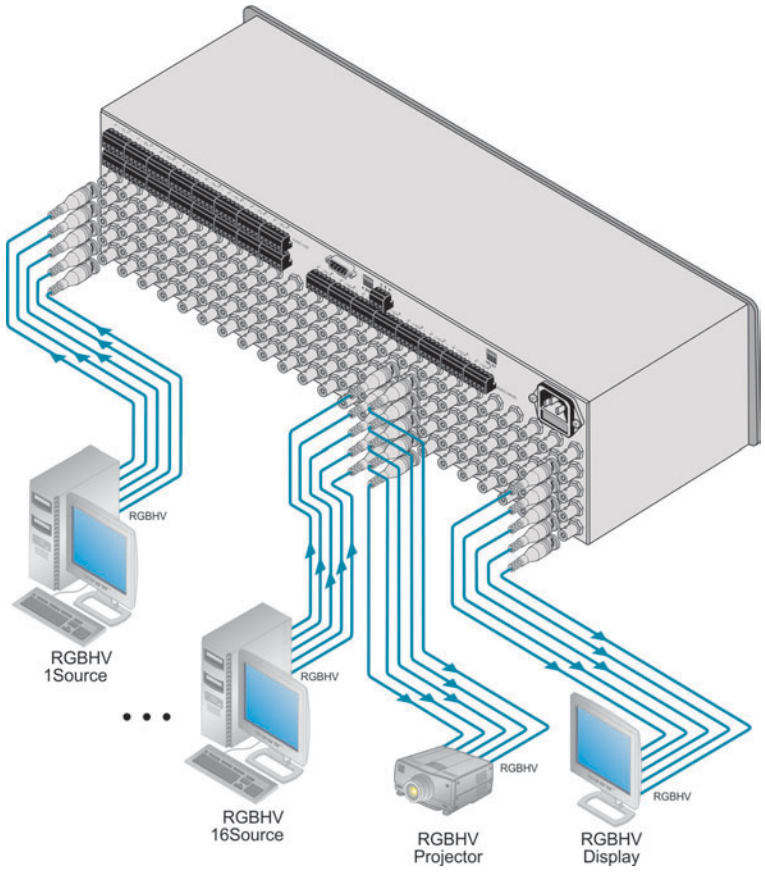

Figure 4: Connecting the VP-1608

5.1 Connecting a Balanced/Unbalanced Stereo Audio Input/Output

This section illustrates how to wire:

- A balanced stereo audio connection, see [Figure 5](#)
- An unbalanced stereo audio input connection, see [Figure 6](#)
- An unbalanced stereo audio output connection, see [Figure 7](#)

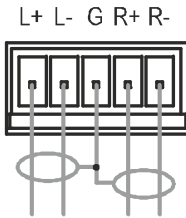

Figure 5: Balanced Stereo Audio Connection

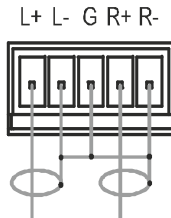

Figure 6: Unbalanced Stereo Audio Input Connection

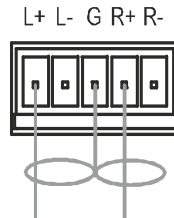

Figure 7: Unbalanced Stereo Audio Output Connection

5.2 Connecting to the VP-1608 via RS-232

You can connect to the **VP-1608** via an RS-232 connection using, for example, a PC. Note that a null-modem adapter/connection is not required.

To connect to the **VP-1608** via RS-232:

- Connect the RS-232 9-pin D-sub rear panel port on the **VP-1608** unit via a 9-wire straight cable (only pin 2 to pin 2, pin 3 to pin 3, and pin 5 to pin 5 need to be connected) to the RS-232 9-pin D-sub port on your PC

5.3 Connecting a PC or Controller to the RS-485 Port

You can operate the **VP-1608** via the RS-485 port from a distance of up to 1200m (3900ft) using any device equipped with an RS-485 port (for example, a PC). For successful communication, you must set the RS-485 machine number and bus termination.

To connect a device with a RS-485 port to the **VP-1608**:

- Connect the A (+) pin on the RS-485 port of the PC to the A (+) pin on the RS-485 port on the rear panel of the **VP-1608**
- Connect the B (-) pin on the RS-485 port of the PC to the B (-) pin on the RS-485 port on the rear panel of the **VP-1608**
- Connect the G pin on the RS-485 port of the PC to the G pin on the RS-485 port on the rear panel of the **VP-1608**

5.4 Setting the MACHINE # DIP-Switches

The MACHINE # determines the address of a **VP-1608** unit when several **VP-1608** units are controlled by a PC or serial controller. Set the MACHINE # on a **VP-1608** unit via DIPS 1, 2, and 3 (DIP 4 is for RS-485 termination), according to the following table:

MACHINE #	DIPS		
	1	2	3
1 Master	OFF	OFF	OFF
2	OFF	OFF	ON
3	OFF	ON	OFF
4	OFF	ON	ON
5	ON	OFF	OFF
6	ON	OFF	ON
7	ON	ON	OFF
8	ON	ON	ON

When using a stand-alone **VP-1608** unit, set the MACHINE # to 1.

When connecting more than one **VP-1608** unit, set the first machine (the Master) connected via RS-232, as MACHINE # 1. The other **VP-1608** slave units (each set to a MACHINE # between 2 and 8) interconnect via their RS-485 ports to the RS-485 port on the Master.

5.5 Setting the DELAY DIP-Switches

To achieve clean transitions when switching between non-genlocked sources, set the delay time—ranging from 0sec to 3.5sec in increments of 0.5sec—via the DELAY DIP-switches, as shown in the following table. The **VP-1608** unit is shipped from the factory set with no delay (0sec).

Sec	DIP 1	DIP 2	DIP 3	DIP 4
0	OFF	OFF	OFF	OFF
0.5	OFF	OFF	OFF	ON
1.0	OFF	OFF	ON	OFF
1.5	OFF	OFF	ON	ON
2.0	OFF	ON	OFF	OFF
2.5	OFF	ON	OFF	ON
3.0	OFF	ON	ON	OFF
3.5	OFF	ON	ON	ON

6 Connecting Multiple VP-1608 Units

You can connect up to eight single **VP-1608** units from a PC or serial controller via RS-232 and RS-485 (see [Section 6.1](#)), or up to seven single **VP-1608** units via RS-485 (see [Section 6.2](#)).

To connect a single **VP-1608** unit to a PC or other RS-232 controller, see [Section 5.2](#).

6.1 Connecting via a PC or Serial Controller

To connect up to eight single **VP-1608** units from a PC or serial controller via RS-232 and RS-485, as shown in [Figure 8](#), do the following:



Always switch off the power to each device before connecting it to your **VP-1608**. After connecting your **VP-1608**, connect its power and then switch on the power to each device.

1. Connect the video sources and acceptors, the appropriate audio sources and acceptors, and the power cord to each **VP-1608** unit.
2. On each **VP-1608** unit, set the MACHINE # DIP-switches, as required (see [Section 5.3](#)).
Set the first unit to MACHINE # 1 (Master), the second unit to MACHINE # 2, and so on - up to MACHINE # 8 for the eighth unit.
3. Connect the RS-232 port on the first **VP-1608** unit to the PC (see [Section 5.1](#)).
4. Interconnect the RS-485 ports on all the **VP-1608** units: from the RS-485 port on the first **VP-1608** unit, to the RS-485 port on the second **VP-1608** unit, and so on – up to the RS-485 port on the eighth **VP-1608** unit.

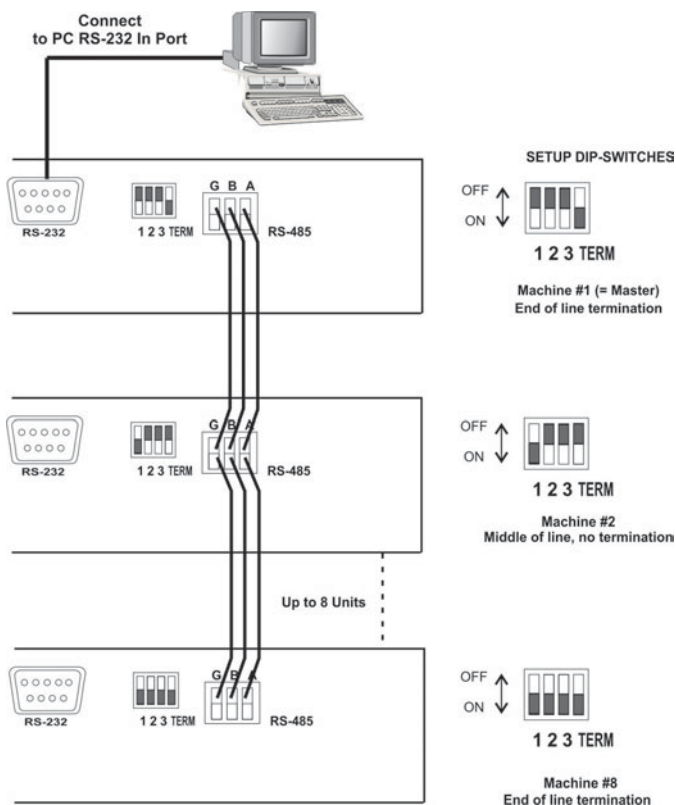

Figure 8: Control Configuration via RS-232 and RS-485

6.2 Connecting via an RS-485 Controller

To connect up to seven single **VP-1608** units via an RS-485 controller, for example, a PC (equipped with an RS-485 interface), do the following:



Always switch off the power to each device before connecting it to your **VP-1608**. After connecting your **VP-1608**, connect its power and then switch on the power to each device.

1. Connect the video sources and acceptors, the appropriate audio sources and acceptors, and the power cord to each **VP-1608** unit.

2. On each **VP-1608** unit, set the MACHINE # DIP-switches, as required. For example, set the first **VP-1608** unit to MACHINE # 2, the second **VP-1608** unit to MACHINE # 3, and so on, up to MACHINE # 8 for the seventh **VP-1608** unit (see [Section 5.3](#)).
3. Terminate the RS-485 line on both the PC and on the last **VP-1608** unit (set DIP 4 to ON).
4. Connect the RS-485 ports from the PC to the RS-485 ports on each of the **VP-1608** units, as follows:
 - Connect the "A" (+) PIN on the RS-485 PC port to the "A" (+) PIN on the RS-485 rear panel ports of the **VP-1608** units
 - Connect the "B" (-) PIN on the RS-485 PC port to the "B" (-) PIN on the RS-485 rear panel ports of the **VP-1608** units
 - If shielded twisted pair cable is used, the shield may be connected to the "G" (Ground) PIN on one of the units

7 Operating Your VP-1608 16x8 RGBHV/Balanced Audio Matrix

This section describes how to operate the **VP-1608**. The section includes:

- Choosing the Audio-Follow-Video or Breakaway option (see [Section 7.1](#))
- Switching OUT-IN combinations (see [Section 7.2](#))
- Confirming settings (see [Section 7.3](#))
- Storing/recalling input/output configurations (see [Section 7.4](#))
- Adjusting the audio gain control (see [section 7.5](#))
- Locking and unlocking the front panel (see [Section 7.6](#))
- Resetting the **VP-1608** (see [Section 7.7](#))
- Displaying unit characteristics (see [Section 7.8](#))

7.1 Using the Audio-Follow-Video or Breakaway Option

By default, the **VP-1608** is setup for use as a single machine. This means that it is a 16x8 RGBHV/Balanced Audio Matrix (in audio-follow-video mode), with all setups empty and each input connected to its corresponding output (for example, input 1 to output 1). The DIP-switches are set up for a typical application using a single machine (see [Figure 9](#)):

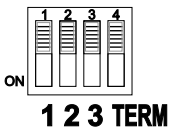

Figure 9: DIP-Switch Setup on a Single Machine

You can switch stereo audio signals in one of two ways, either:

- Audio-follow-video (AFV), where audio and video channels switch together, or
- Breakaway, where audio and video channels switch independently

7.1.1 Setting the Audio-Follow-Video

To set the audio-follow-video (AFV) option, press the AFV button:

- If the AUDIO and VIDEO configurations are the same, the AFV button illuminates. The audio follows the video
- If the AUDIO differs from the VIDEO, the TAKE and the AUDIO buttons flash. Also, the audio outputs in the INPUT STATUS 7-segment display that are changed, flash (warning that you are about to modify the audio configuration for AFV operation). Press the TAKE button to confirm the modification. The audio follows the video

7.1.2 Setting Breakaway

To set the breakaway option:

Press either the AUDIO (for audio control only) or the VIDEO (for video control only) button:

- If the AUDIO button illuminates, switching operations relate to audio
- If the VIDEO button illuminates, switching operations relate to video

7.2 Switching OUT-IN Combinations

To switch a video/audio input to a video/audio output, do the following:

1. Press an OUTPUT SELECTOR button.
The corresponding input number in the *INPUT STATUS* 7-segment display flashes.
2. Press an INPUT SELECTOR button.
The selected input switches to the selected output.

For example, press the ALL button and then INPUT SELECTOR button # 2 to connect input # 2 to all the outputs.

7.3 Confirming Settings

Choose to work in the AT ONCE or the CONFIRM mode, as explained in [Section 7.3.1](#). When the **VP-1608** operates in the AT ONCE mode, pressing an OUT-IN combination implements the switch immediately. In the CONFIRM mode, the TAKE button must be pressed to authorize the switch.

In the AT ONCE mode, you save time as execution is immediate and actions require no user confirmation. However, no protection is offered against changing an action in error.

In the CONFIRM mode:

- You can key-in several actions and then confirm them by pressing the TAKE button, to simultaneously activate the multiple switches
- Every action requires user confirmation, to protect against erroneous switching
- Execution is delayed until the user confirms the action
Failure to press the TAKE button within one minute (the timeout) aborts the action.

7.3.1 Toggling between the AT ONCE and CONFIRM Modes

To toggle between the AT ONCE and CONFIRM modes, do the following:

1. Press the TAKE button to toggle from the AT ONCE mode (the TAKE button does not illuminate) to the CONFIRM mode (the TAKE button illuminates). The TAKE button illuminates and actions now require user confirmation.
2. Press the illuminated TAKE button to toggle from the CONFIRM mode back to the AT ONCE mode. The TAKE button turns off and actions no longer require user confirmation.

7.3.2 Confirming a Switching Action

To confirm a switching action (in CONFIRM mode), do the following:

1. Press an OUT-IN combination.
The corresponding input number that is displayed in the *INPUT STATUS* 7-segment display flashes. The TAKE button also flashes.
2. Press the flashing TAKE button to confirm the action.
The corresponding input number that is displayed in the *INPUT STATUS* 7-segment display no longer flashes. The TAKE button illuminates.

To confirm several actions (in CONFIRM mode), do the following:

1. Press each OUT-IN combination in sequence.
The corresponding input numbers that are displayed in the *INPUT STATUS* 7-segment display blink. The TAKE button also flashes.
2. Press the flashing TAKE button to confirm all the actions.
The corresponding input numbers that are displayed in the *INPUT STATUS* 7-segment display no longer blink. The TAKE button illuminates.

7.4 Storing/Recalling Input/Output Configurations

You can store and recall up to 15 input/output configurations (or presets) in non-volatile memory, using the INPUT SELECTOR buttons 1 to 15. The 15 input/output configurations also include the relevant audio-follow-video/breakaway option definition, the video configurations, the audio configurations, the audio gain level for each of the 16 inputs, and the audio gain level for each of the eight outputs.

7.4.1 Storing an Input/Output Configuration

To store the current status in memory, do the following:

1. Press the STO button.
The STO button flashes.

2. Press one of the INPUT SELECTOR buttons from 1 to 15 (this becomes the setup # in which the current status is stored). If in the CONFIRM mode, press the flashing TAKE button to confirm the action.

The memory stores the data at that reference.

7.4.2 Recalling an Input/Output Configuration

To recall an input/output configuration, do the following:

1. Press the RCL button.
The RCL button flashes.
2. Press the appropriate INPUT SELECTOR button (the INPUT SELECTOR button # corresponding to the setup #). If in the CONFIRM mode, the setup flashes on the display and is only implemented after pressing the TAKE button.

The memory recalls the stored data from that reference.

To view the saved input/output configurations, set the **VP-1608** to the CONFIRM mode and manually scan all the input/output configurations.

Press RCL followed by an INPUT SELECTOR button to display a configuration. To recall this configuration, press TAKE to select it. If not, repeat the above to display another configuration.

7.4.3 Deleting an Input/Output Configuration

To delete an input/output configuration, do the following:

1. Press the STO and RCL buttons simultaneously.
Both the STO and RCL buttons blink.
2. Press the appropriate INPUT SELECTOR button.
This erases that specific input/output configuration from the memory, leaving it empty and available.

Storing a new configuration over a previous configuration (without deleting it first) replaces the previous configuration.

7.5 Adjusting the Audio Gain Control

You can adjust the gain control for each input and output signal using the latest K-Router Windows®-based control software (provided). See the Hex Tables for Audio Input/Output Gain Control in [Section 11](#).

7.6 Locking and Unlocking the Front Panel

To prevent changing the settings accidentally or tampering with the unit via the front panel buttons, lock your **VP-1608**. Unlocking releases the protection mechanism.

Nevertheless, even though the front panel is locked you can still operate via RS-232 or RS-485 serial (remote controller or PC), as well as via the Kramer RC-IR3 Infrared Remote Control Transmitter.

To lock the VP-1608:

- Press the LOCK button for more than two seconds
The front panel is locked and the LOCK button flashes

To unlock the VP-1608:

- Press the LOCK button for more than two seconds
The front panel unlocks and the LOCK button no longer flashes

7.7 Resetting the VP-1608 16x8 RGBHV/Balanced Audio Matrix

You can reset the **VP-1608** unit to the:

- Current status (“soft reset”) (reloads the current setup without having to switch the power off and on)
- Factory default (resets to the pre-installed factory default state)

Each **VP-1608** unit ships in its factory default state that is a 16x8 RGBHV/Balanced Audio Matrix (in audio-follow-video mode), with all setups empty and each input connected to its corresponding output (for example, 1-to-1).

7.7.1 Resetting to the Current Status

You can reset the **VP-1608** unit to the current status (reloads the current setup)

To reset a VP-1608 unit to the current status, do the following:

- Press INPUT buttons 1 and 5 simultaneously for 3 seconds
The **VP-1608** unit resets to the current status, momentarily displaying the unit characteristics, as described in [Section 7.8](#). In addition, the unit characteristics also appear immediately (and automatically) after switching on the power

7.7.2 Resetting to the Factory Default State

You can reset the **VP-1608** unit to the factory default state.

To reset a VP-1608 unit to the factory default state, do the following:

- Press OUTPUT buttons 1 and 5 simultaneously for 3 seconds
The **VP-1608** unit resets to its factory default state, momentarily displaying the unit characteristics, as described in [Section 7.8](#)

7.8 Displaying Unit Characteristics

Switching on and/or resetting to the Current Status (see [Section 7.7.1](#)) or to the Factory Default State (see [Section 7.7.2](#)), the **VP-1608** unit momentarily displays the following characteristics on the front panel (as [Figure 10](#) illustrates):

- The number included in the product name (for example, **1608**)
- The firmware version number

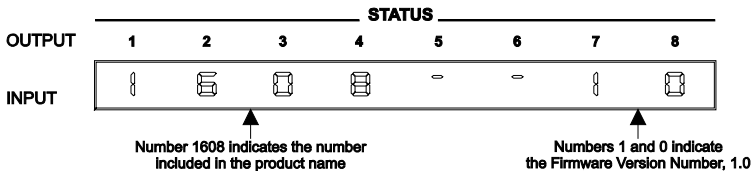

Figure 10: VP-1608 Unit Characteristics

8 Flash Memory Upgrade

The **VP-1608** firmware is located in FLASH memory, which lets you upgrade to the latest Kramer firmware version in minutes! The process involves:

- Downloading from the Internet (see [Section 8.1](#))
- Connecting the PC to the RS-232 port (see [Section 8.2](#))
- Upgrading the firmware (see [Section 8.3](#))

8.1 Downloading from the Internet

To download the up-to-date file from the Internet:

1. Go to our Web site at <http://www.kramerelectronics.com> and download the file: “*FLIP_VP1608.zip*” from the Technical Support section.
2. Extract the file: “*FLIP_VP1608.zip*” to a folder (for example, C:\Program Files\Kramer Flash).
3. Create a shortcut on your desktop to the file: “*FLIP.EXE*”.

8.2 Connecting the PC to the RS-232 Port

Before installing the latest Kramer firmware version on a **VP-1608** unit, do the following:

1. Connect the RS-232 9-pin D-sub (F) rear panel port on the **VP-1608** to the RS-232 9-pin D-sub (F) COM port on your PC (see [Section 5.1](#)) with a 9-wire flat cable.
2. Connect the power on the **VP-1608** unit and switch it ON.
3. Set the underside Flash Program switches (see [Figure 11](#)), as follows:
 - Set Flash Program switch 1 to **Program**
 - Set Flash Program switch 2 to **Reset**
 - Set Flash Program switch 2 to **Normal**

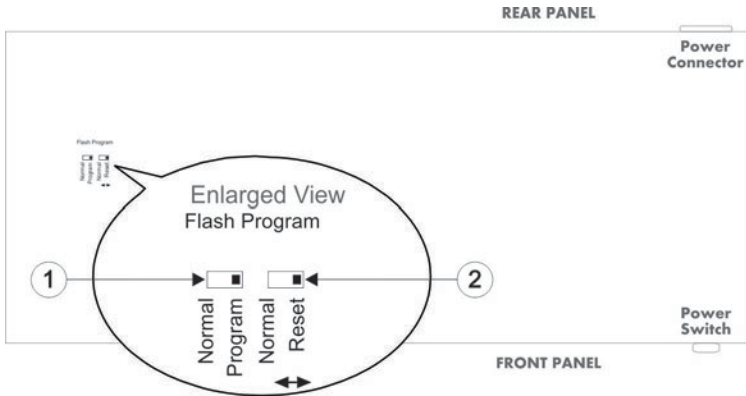

Figure 11: VP-1608 Underside Flash Program Switches Set for Upgrade

8.3 Upgrading the Firmware

To upgrade the firmware, follow these steps:

1. Double-click the desktop icon: “Shortcut to FLIP.EXE”.

The Splash screen appears as follows:



Figure 12: Splash Screen

2. After a few seconds, the Splash screen is replaced by the “Atmel – Flip” window:



Figure 13: Atmel – Flip Window

3. Press the keyboard shortcut key **F2** (or select the “*Select*” command from the *Device* menu, or press the integrated circuit icon in the upper right corner of the window).

The “*Device Selection*” window appears:



Figure 14: Device Selection Window

4. Click the button next to the name of the device and select from the list:
AT89C51RD2.

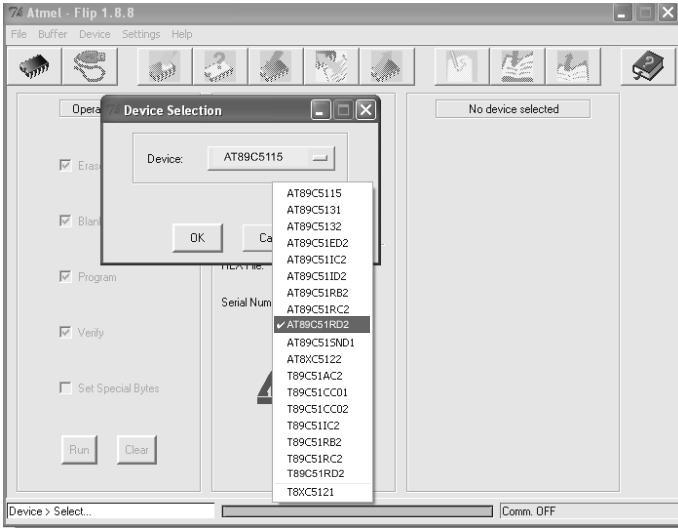

Figure 15: Device Selection Window

5. Click **OK** and select “Load Hex” from the File menu.

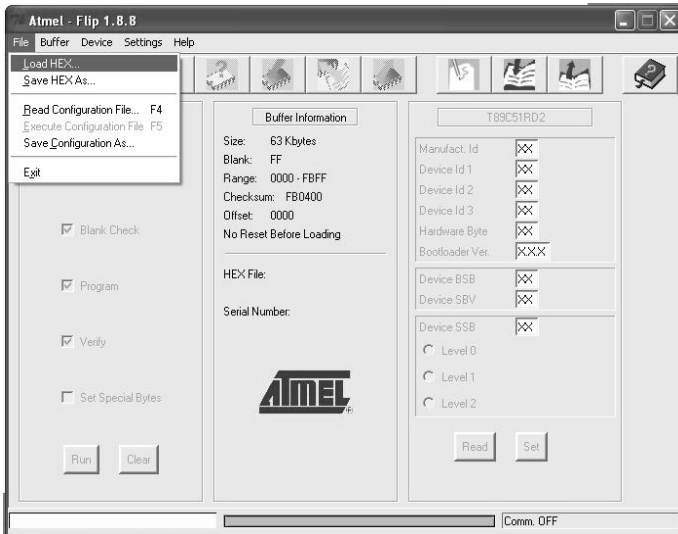

Figure 16: Loading the Hex

- The Open File window opens. Select the correct HEX file that contains the updated version of the firmware for the **VP-1608** (for example 1608M_V1p2.hex) and click **Open**.
- Press the keyboard shortcut key **F3** (or select the “Communication/RS232” command from the Settings menu, or press the keys: Alt- SCR). The “RS232” window appears. Change the COM port according to the configuration of your computer and select the 9600 baud rate:

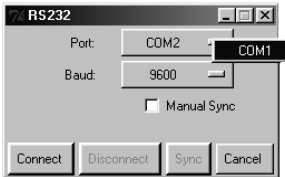

Figure 17: RS-232 Window

- Click **Connect**.

In the “Atmel – Flip” window, in the Operations Flow column, the Run button is active, and the name of the chip appears as the name of the third column: AT89C51RD2.

Verify that in the Buffer Information column, the “HEX File: *VP1608.hex*” appears.

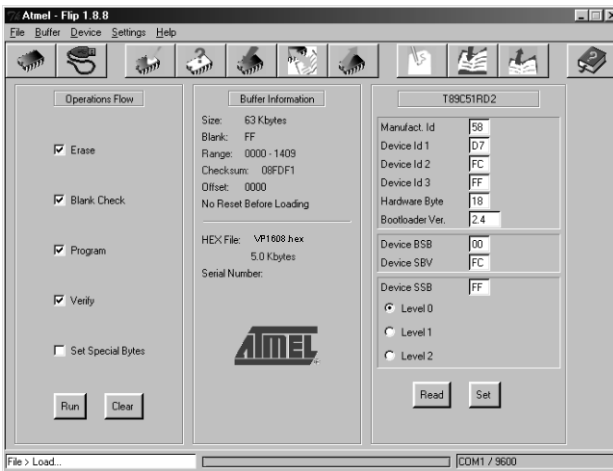

Figure 18: Atmel – Flip Window (Connected)

- Click Run. After each stage of the operation is completed, the check-box for that stage becomes colored green (see also the blue progress indicator on the status bar).

When the operation is completed, all 4 check-boxes are colored green and the status bar message: Memory Verify Pass appears:

If an error message: "Not Finished" shows, click Run again.

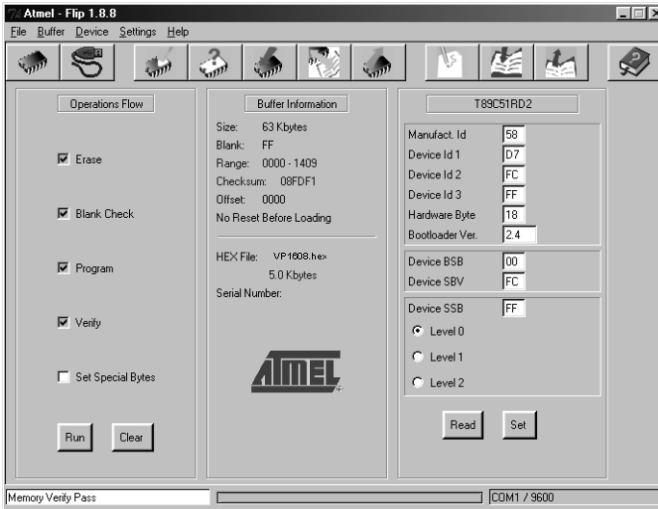

Figure 19: Atmel – Flip Window (Operation Completed)

- Close the "Atmel – Flip" window.
- Disconnect the power on the **VP-1608**.
- Set both the underside switches: Flash Program switch 1 and Flash Program switch 2 (see [Figure 3](#)) to Normal.
- Connect the power on the **VP-1608**.
Upon initialization, the new **VP-1608** software version shows in the INPUT STATUS 7-segment Display.

9 Technical Specifications

INPUTS:	16 x 3 video (RGB) 0.7Vpp/75Ω on BNC connectors. 16 x 2 H&V, TTL level on BNC connectors 16 balanced audio stereo on detachable terminal blocks
OUTPUTS:	8 x 3 video (RGB) 0.7Vpp/75Ω on BNC connectors 8 x 2 H&V, TTL level/75Ω on BNC connectors 8 balanced audio stereo on detachable terminal blocks
VIDEO BANDWIDTH (-3dB):	400MHz
AUDIO BANDWIDTH (-3dB):	30kHz
VIDEO S/N RATIO:	71.7dB
AUDIO S/N RATIO:	74.5dB unweighted (1Vpp)
VIDEO CROSSTALK:	-62.5dB @5MHz
CONTROL:	Front panel switches and IR. RS-232 and RS-485 may also control input and output audio levels
AUDIO CONTROL:	Mute, -46dB to +10dB gain range, via RS-232, RS-485, IR
AUDIO THD:	0.028% (1kHz)
POWER SOURCE:	230V AC, 50/60Hz (115V AC, USA), 28VA
OPERATING TEMPERATURE:	0° to +55°C (32° to 131°F)
STORAGE TEMPERATURE:	-45° to +72°C (-49° to 162°F)
HUMIDITY:	10% to 90%, RHL non-condensing
DIMENSIONS:	19" x 7" x 3U W, D, H, rack mountable
WEIGHT:	5.5kg, (12.2lbs) approx.
ACCESSORIES:	Power cord, Windows®-based Kramer control software, IR remote control
Specifications are subject to change without notice at http://www.kramerelectronics.com	

10 Table of Hex Codes for Serial Communication

This table lists the hex values for switching a single machine (MACHINE # 1) via RS-232/RS-485 in breakaway mode:

OUT	Switching Video Channels								Switching Audio Channels							
	1	2	3	4	5	6	7	8	1	2	3	4	5	6	7	8
IN 1	01	01	01	01	01	01	01	01	02	02	02	02	02	02	02	02
	81	81	81	81	81	81	81	81	81	81	81	81	81	81	81	81
	81	82	83	84	85	86	87	88	81	82	83	84	85	86	87	88
	81	81	81	81	81	81	81	81	81	81	81	81	81	81	81	81
IN 2	01	01	01	01	01	01	01	01	02	02	02	02	02	02	02	02
	82	82	82	82	82	82	82	82	82	82	82	82	82	82	82	82
	81	82	83	84	85	86	87	88	81	82	83	84	85	86	87	88
	81	81	81	81	81	81	81	81	81	81	81	81	81	81	81	81
IN 3	01	01	01	01	01	01	01	01	02	02	02	02	02	02	02	02
	83	83	83	83	83	83	83	83	83	83	83	83	83	83	83	83
	81	82	83	84	85	86	87	88	81	82	83	84	85	86	87	88
	81	81	81	81	81	81	81	81	81	81	81	81	81	81	81	81
IN 4	01	01	01	01	01	01	01	01	02	02	02	02	02	02	02	02
	84	84	84	84	84	84	84	84	84	84	84	84	84	84	84	84
	81	82	83	84	85	86	87	88	81	82	83	84	85	86	87	88
	81	81	81	81	81	81	81	81	81	81	81	81	81	81	81	81
IN 5	01	01	01	01	01	01	01	01	02	02	02	02	02	02	02	02
	85	85	85	85	85	85	85	85	85	85	85	85	85	85	85	85
	81	82	83	84	85	86	87	88	81	82	83	84	85	86	87	88
	81	81	81	81	81	81	81	81	81	81	81	81	81	81	81	81
IN 6	01	01	01	01	01	01	01	01	02	02	02	02	02	02	02	02
	86	86	86	86	86	86	86	86	86	86	86	86	86	86	86	86
	81	82	83	84	81	82	83	84	81	82	83	84	81	82	83	84
	81	81	81	81	81	81	81	81	81	81	81	81	81	81	81	81
IN 7	01	01	01	01	01	01	01	01	02	02	02	02	02	02	02	02
	87	87	87	87	87	87	87	87	87	87	87	87	87	87	87	87
	81	82	83	84	85	86	87	88	81	82	83	84	85	86	87	88
	81	81	81	81	81	81	81	81	81	81	81	81	81	81	81	81
IN 8	01	01	01	01	01	01	01	01	02	02	02	02	02	02	02	02
	88	88	88	88	88	88	88	88	88	88	88	88	88	88	88	88
	81	82	83	84	85	86	87	88	81	82	83	84	85	86	87	88
	81	81	81	81	81	81	81	81	81	81	81	81	81	81	81	81
IN 9	01	01	01	01	01	01	01	01	02	02	02	02	02	02	02	02
	89	89	89	89	89	89	89	89	89	89	89	89	89	89	89	89
	81	82	83	84	85	86	87	88	81	82	83	84	85	86	87	88
	81	81	81	81	81	81	81	81	81	81	81	81	81	81	81	81
IN 10	01	01	01	01	01	01	01	01	02	02	02	02	02	02	02	02
	8A	8A	8A	8A	8A	8A	8A	8A	8A	8A	8A	8A	8A	8A	8A	8A
	81	82	83	84	85	86	87	88	81	82	83	84	85	86	87	88
	81	81	81	81	81	81	81	81	81	81	81	81	81	81	81	81
IN 11	01	01	01	01	01	01	01	01	02	02	02	02	02	02	02	02
	8B	8B	8B	8B	8B	8B	8B	8B	8B	8B	8B	8B	8B	8B	8B	8B
	81	82	83	84	85	86	87	88	81	82	83	84	85	86	87	88
	81	81	81	81	81	81	81	81	81	81	81	81	81	81	81	81
IN 12	01	01	01	01	01	01	01	01	02	02	02	02	02	02	02	02
	8C	8C	8C	8C	8C	8C	8C	8C	8C	8C	8C	8C	8C	8C	8C	8C
	81	82	83	84	85	86	87	88	81	82	83	84	85	86	87	88
	81	81	81	81	81	81	81	81	81	81	81	81	81	81	81	81
IN 13	01	01	01	01	01	01	01	01	02	02	02	02	02	02	02	02
	8D	8D	8D	8D	8D	8D	8D	8D	8D	8D	8D	8D	8D	8D	8D	8D
	81	82	83	84	85	86	87	88	81	82	83	84	85	86	87	88
	81	81	81	81	81	81	81	81	81	81	81	81	81	81	81	81
IN 14	01	01	01	01	01	01	01	01	02	02	02	02	02	02	02	02
	8E	8E	8E	8E	8E	8E	8E	8E	8E	8E	8E	8E	8E	8E	8E	8E
	81	82	83	84	85	86	87	88	81	82	83	84	85	86	87	88
	81	81	81	81	81	81	81	81	81	81	81	81	81	81	81	81

	Switching Video Channels								Switching Audio Channels							
OUT	1	2	3	4	5	6	7	8	1	2	3	4	5	6	7	8
IN 15	01	01	01	01	01	01	01	01	02	02	02	02	02	02	02	02
	8F	8F	8F	8F	8F	8F	8F	8F	8F	8F	8F	8F	8F	8F	8F	8F
	81	82	83	84	85	86	87	88	81	82	83	84	85	86	87	88
	81	81	81	81	81	81	81	81	81	81	81	81	81	81	81	81
IN 16	01	01	01	01	01	01	01	01	02	02	02	02	02	02	02	02
	90	90	90	90	90	90	90	90	90	90	90	90	90	90	90	90
	81	82	83	84	85	86	87	88	81	82	83	84	85	86	87	88
	81	81	81	81	81	81	81	81	81	81	81	81	81	81	81	81

11 Hex Tables for Audio Input/Output Gain Control

[Sections 11.1](#) and [11.2](#) contain the tables of hex codes for input and output signal gain control adjustment, respectively.

11.1 Hex Tables for Audio Input Gain Control

Before adjusting the audio inputs gain, instruction 42, the AUDIO PARAMETER SETTINGS FOR INSTRUCTIONS 22, 24, 25 is sent. This command is sent once, and the “audio inputs gain adjustment” mode continues until instruction 42 changes to the “audio outputs gain adjustment” mode:

2A	86	80	81
----	----	----	----

The next table lists the hex values for the audio gain control of the 16 inputs:

		INPUTS																
		1	2	3	4	5	6	7	8	9	10	11	12	13	14	15	16	ALL
Instruction # 22	Audio Level = 0	16	16	16	16	16	16	16	16	16	16	16	16	16	16	16	16	16
		81	82	83	84	85	86	87	88	89	8A	8B	8C	8D	8E	8F	90	80
		80	80	80	80	80	80	80	80	80	80	80	80	80	80	80	80	80
Instruction # 22	Audio Level = 1	81	81	81	81	81	81	81	81	81	81	81	81	81	81	81	81	81
		16	16	16	16	16	16	16	16	16	16	16	16	16	16	16	16	16
		81	82	83	84	85	86	87	88	89	8A	8B	8C	8D	8E	8F	90	80
Instruction # 22	Audio Level = 10	81	81	81	81	81	81	81	81	81	81	81	81	81	81	81	81	81
		16	16	16	16	16	16	16	16	16	16	16	16	16	16	16	16	16
		8A	8A	8A	8A	8A	8A	8A	8A	8A	8A	8A	8A	8A	8A	8A	8A	8A
Instruction # 22	Audio Level = 127	81	81	81	81	81	81	81	81	81	81	81	81	81	81	81	81	81
		16	16	16	16	16	16	16	16	16	16	16	16	16	16	16	16	16
		FF	FF	FF	FF	FF	FF	FF	FF	FF	FF	FF	FF	FF	FF	FF	FF	FF
Instruction # 63	Audio Level = 128	81	81	81	81	81	81	81	81	81	81	81	81	81	81	81	81	81
		3F	3F	3F	3F	3F	3F	3F	3F	3F	3F	3F	3F	3F	3F	3F	3F	3F
		80	80	80	80	80	80	80	80	80	80	80	80	80	80	80	80	80
Instruction # 22	Audio Level = 216 (1:1)	81	81	81	81	81	81	81	81	81	81	81	81	81	81	81	81	81
		16	16	16	16	16	16	16	16	16	16	16	16	16	16	16	16	16
		81	82	83	84	85	86	87	88	89	8A	8B	8C	8D	8E	8F	90	80
Instruction # 63	Audio Level = 255 (3:1)	81	81	81	81	81	81	81	81	81	81	81	81	81	81	81	81	81
		3F	3F	3F	3F	3F	3F	3F	3F	3F	3F	3F	3F	3F	3F	3F	3F	3F
		80	80	80	80	80	80	80	80	80	80	80	80	80	80	80	80	80
Instruction # 22	Audio Level = 255 (3:1)	81	81	81	81	81	81	81	81	81	81	81	81	81	81	81	81	81
		16	16	16	16	16	16	16	16	16	16	16	16	16	16	16	16	16
		FF	FF	FF	FF	FF	FF	FF	FF	FF	FF	FF	FF	FF	FF	FF	FF	FF

11.2 Hex Tables for Audio Output Gain Control

Before adjusting the audio outputs gain, instruction 42, the AUDIO PARAMETER SETTINGS FOR INSTRUCTIONS 22, 24, 25 is sent. The command sends once, and the “audio outputs gain adjustment” mode continues until instruction 42 changes to the “audio inputs gain adjustment” mode:

2A	87	80	81
----	----	----	----

The next table lists the hex values for the audio gain control of the eight outputs:

		OUTPUTS								
		1	2	3	4	5	6	7	8	ALL
Instruction # 22	Audio Level = 0 (Mute*)	16	16	16	16	16	16	16	16	16
		81	82	83	84	85	86	87	88	80
		80	80	80	80	80	80	80	80	80
		81	81	81	81	81	81	81	81	81
Instruction # 22	Audio Level = 1	16	16	16	16	16	16	16	16	16
		81	82	83	84	85	86	87	88	80
		81	81	81	81	81	81	81	81	81
		81	81	81	81	81	81	81	81	81
Instruction # 22	Audio Level = 10	16	16	16	16	16	16	16	16	16
		81	82	83	84	85	86	87	88	80
		8A	8A	8A	8A	8A	8A	8A	8A	8A
		81	81	81	81	81	81	81	81	81
Instruction # 22	Audio Level = 127	16	16	16	16	16	16	16	16	16
		81	82	83	84	85	86	87	88	80
		FF	FF	FF	FF	FF	FF	FF	FF	FF
		81	81	81	81	81	81	81	81	81
Instruction # 63	Audio Level = 128	3F	3F	3F	3F	3F	3F	3F	3F	3F
		80	80	80	80	80	80	80	80	80
		81	81	81	81	81	81	81	81	81
		81	81	81	81	81	81	81	81	81
Instruction # 22	Audio Level = 216 (1:1)	16	16	16	16	16	16	16	16	16
		81	82	83	84	85	86	87	88	80
		80	80	80	80	80	80	80	80	80
		81	81	81	81	81	81	81	81	81
Instruction # 63	Audio Level = 216 (1:1)	3F	3F	3F	3F	3F	3F	3F	3F	3F
		80	80	80	80	80	80	80	80	80
		81	81	81	81	81	81	81	81	81
		81	81	81	81	81	81	81	81	81
Instruction # 22	Audio Level = 255 (3:1)	16	16	16	16	16	16	16	16	16
		81	82	83	84	85	86	87	88	80
		D8	D8	D8	D8	D8	D8	D8	D8	D8
		81	81	81	81	81	81	81	81	81
Instruction # 63	Audio Level = 255 (3:1)	3F	3F	3F	3F	3F	3F	3F	3F	3F
		80	80	80	80	80	80	80	80	80
		81	81	81	81	81	81	81	81	81
		81	81	81	81	81	81	81	81	81
Instruction # 22	Audio Level = 255 (3:1)	16	16	16	16	16	16	16	16	16
		81	82	83	84	85	86	87	88	80
		FF	FF	FF	FF	FF	FF	FF	FF	FF
		81	81	81	81	81	81	81	81	81

*In the Mute state, the audio output is physically disconnected from the input

12 Kramer Protocol 2000

The Kramer Protocol 2-000 RS-232/RS-485 communication uses four bytes of information as defined below.

MSB								LSB
		DESTINATION	INSTRUCTION					
0	D	N5	N4	N3	N2	N1	N0	
7	6	5	4	3	2	1	0	

1st byte

		INPUT					
1	I6	I5	I4	I3	I2	I1	I0
7	6	5	4	3	2	1	0

2nd byte

		OUTPUT					
1	O6	O5	O4	O3	O2	O1	O0
7	6	5	4	3	2	1	0

3rd byte

		MACHINE NUMBER					
1	OVN	X	M4	M3	M2	M1	M0
7	6	5	4	3	2	1	0

4th byte

1st BYTE: Bit 7 – Defined as 0.

D – "DESTINATION": 0 - for sending information to the switchers (from the PC);

1 - for sending to the PC (from the switcher).

N5...N0 – "INSTRUCTION"

The function that is to be performed by the switcher(s) is defined by the INSTRUCTION (6 bits). Similarly, if a function is performed via the machine's keyboard, then these bits are set with the INSTRUCTION NO., which was performed. The instruction codes are defined according to the table below (INSTRUCTION NO. is the value to be set for N5...N0).

2nd BYTE: Bit 7 – Defined as 1.
I6...I0 – "INPUT".

When switching (ie. instruction codes 1 and 2), the INPUT (7 bits) is set as the input number which is to be switched.

Similarly, if switching is done via the machine's front-panel, then these bits are set with the INPUT NUMBER which was switched. For other operations, these bits are defined according to the table.

3rd BYTE: Bit 7 – Defined as 1.
O6...O0 – "OUTPUT".

When switching (ie. instruction codes 1 and 2), the OUTPUT (7 bits) is set as the output number which is to be switched.

Similarly, if switching is done via the machine's front-panel, then these bits are set with the OUTPUT NUMBER which was switched. For other operations, these bits are defined according to the table.

4th BYTE: Bit 7 – Defined as 1.
Bit 5 – Don't care.
OVN – Machine number override.
M4...M0 – MACHINE NUMBER.

Used to address machines in a system via their machine numbers. When several machines are controlled from a single serial port, they are usually configured together with each machine having an individual machine number. If the OVR bit is set, then all machine numbers accept (implement) the command, and the addressed machine replies. For a single machine controlled via the serial port, always set M4...M0 = 1, and make sure that the machine itself is configured as MACHINE NUMBER = 1.



All the values in the table are decimal, unless otherwise stated

INSTRUCTION		DEFINITION FOR SPECIFIC INSTRUCTION		NOTE
#	DESCRIPTION	INPUT	OUTPUT	
0	RESET VIDEO	0	0	1
1	SWITCH VIDEO	Set equal to video input which is to be switched (0 = disconnect)	Set equal to video output which is to be switched (0 = to all the outputs)	2, 15
2	SWITCH AUDIO	Set equal to audio input which is to be switched (0 = disconnect)	Set equal to audio output which is to be switched (0 = to all the outputs)	2
3	STORE VIDEO STATUS	Set as SETUP #	0 - to store 1 - to delete	2, 3, 15
4	RECALL VIDEO STATUS	Set as SETUP #	0	2, 3, 15
5	REQUEST STATUS OF A VIDEO OUTPUT	Set as SETUP #	Equal to output number whose status is reqd	4, 3
6	REQUEST STATUS OF AN AUDIO OUTPUT	Set as SETUP #	Equal to output number whose status is reqd	4, 3
8	BREAKAWAY SETTING	0	0 - audio-follow-video 1 - audio breakaway	2
		1	0 - FOLLOW mode 1 - Normal mode	15
11	REQUEST BREAKAWAY SETTING	Set as SETUP #, or set to 126 or 127 to request if machine has this function	0 - Request audio breakaway setting 1 - Request "FOLLOW" setting	3, 4, 6, 15
12	REQUEST VIDEO/AUDIO TYPE SETTING	Set as SETUP #, or set to 126 or 127 to request if machine has this function	0 - for video 1 - for audio 2 - for VGA	3, 4, 6
15	REQUEST WHETHER SETUP IS DEFINED	Set as SETUP #	0	8
16	ERROR/BUSY	0	0 - error 1 - invalid instruction 2 - out of range 3 - machine busy	9
17	RESERVED	----	----	10
18	RESET AUDIO	0	0	1
19	STORE AUDIO STATUS	Set as SETUP #	0 - to store 1 - to delete	2, 3
20	RECALL AUDIO STATUS	Set as SETUP #	0	2, 3
22	SET AUDIO PARAMETER	Equal to input/output number whose gain is to be set (0 = all)	Set as parameter value	2, 11, 23
24	INCREASE/DECREASE AUDIO PARAMETER	Equal to input/output number whose parameter is to be increased/decreased (0 = all)	0 - increase output 1 - decrease output 2 - increase left output 3 - decrease left output 4 - increase right output 5 - decrease right output 6 - increase input 7 - decrease input 8 - increase left input 9 - decrease left input 10 - increase right input 11 - decrease right input	23
25	REQUEST AUDIO PARAMETER	Equal to input/output number whose parameter is requested	0	6, 23
30	LOCK FRONT PANEL	0 - Panel unlocked 1 - Panel locked	0	2
31	REQUEST WHETHER PANEL IS LOCKED	0	0	16
42	AUDIO PARAMETER SETTINGS FOR INSTRUCTIONS 22, 24, 25	INPUT Bit: I0 - 0=input, 1=output I1 - Left I2 - Right	0 - Gain 1 - Bass 2 - Treble 3 - Midrange	23
57	SET AUTO-SAVE	I3 - no save I4 - auto-save	0	12, 2

INSTRUCTION		DEFINITION FOR SPECIFIC INSTRUCTION		NOTE
#	DESCRIPTION	INPUT	OUTPUT	
59	LOAD VIDEO DATA	Set equal to video input (0 = disconnect) (127 = load SETUP #)	Set equal to video output (0 = to all the outputs) or SETUP #	21, 22
60	LOAD AUDIO DATA	Set equal to audio input (0 = disconnect) (127 = load SETUP #)	Set equal to audio output (0 = to all the outputs) or SETUP #	21, 22
61	IDENTIFY MACHINE	1 - video machine name 2 - audio machine name 3 - video software version 4 - audio software version 5 - RS422 controller name 6 - RS422 controller version 7 - remote control name 8 - remote software version 9 - Protocol 2000 revision	0 - Request first 4 digits 1 - Request first suffix 2 - Request second suffix 3 - Request third suffix 10 - Request first prefix 11 - Request second prefix 12 - Request third prefix	13
62	DEFINE MACHINE	1 - number of inputs 2 - number of outputs 3 - number of setups	1 - for video 2 - for audio 3 - for SDI 4 - for remote panel 5 - for RS-422 controller	14
63	EXTENDED DATA	7 MSBs for INPUT data	7 MSBs for OUTPUT data	19

NOTES on the above table:

NOTE 1 - When the master switcher is reset, (e.g. when it is turned on), the reset code is sent to the PC. If this code is sent to the switchers, it resets according to the present power-down settings.

NOTE 2 - These are bi-directional definitions. That is, if the switcher receives the code, it performs the instruction; and if the instruction is performed (due to a keystroke operation on the front panel), then these codes are sent. For example, if the HEX code

01 85 88 83

was sent from the PC, then the switcher (machine 3) switches input 5 to output 8. If the user switched input 1 to output 7 via the front panel keypad, then the switcher sends HEX codes:

41 81 87 83

to the PC.

When the PC sends one of the commands in this group to the switcher, then, if the instruction is valid, the switcher replies by sending to the PC the same four bytes that it was sent (except for the first byte, where the DESTINATION bit is set high).

NOTE 3 - SETUP # 0 is the present setting. SETUP # 1 and higher are the settings saved in the switcher's memory, (i.e. those used for Store and Recall).

NOTE 4 - The reply to a "REQUEST" instruction is as follows: the same instruction and INPUT codes as were sent are returned, and the OUTPUT is assigned the value of the requested parameter. The replies to instructions 10 and 11 are as per the definitions in instructions 7 and 8 respectively. For example, if the present status of machine number 5 is breakaway setting, then the reply to the HEX code

0B 80 80 85

would be HEX codes

4B 80 81 85

NOTE 6 - If INPUT is set to 127 for these instructions, then, if the function is defined on this machine, it replies with OUTPUT=1. If the function is not defined, then the machine replies with OUTPUT=0, or with an error (invalid instruction code).

If the INPUT is set to 126 for these instructions, then, if possible, the machine returns the current setting of this function, even for the case that the function is not defined. For example, for a video switcher which always switches during the VIS of input #1, (and its VIS setting cannot be programmed otherwise), the reply to the HEX code

0A FE 80 81 (i.e. request VIS setting, with INPUT set as 126dec)

would be HEX codes

4A FE 81 81 (i.e. VIS setting = 1, which is defined as VIS from input #1).

NOTE 8 - The reply to the "REQUEST WHETHER SETUP IS DEFINED" is as in TYPE 3 above, except that here the OUTPUT is assigned with the value 0 if the setup is not defined; or 1 if it is defined.

NOTE 9 - An error code is returned to the PC if an invalid instruction code was sent to the switcher, or if a parameter associated with the instruction is out of range (e.g. trying to save to a setup greater than the highest one, or trying to switch an input or output greater than the highest one defined). This code is also returned to the PC if an RS-232 instruction is sent while the machine is being programmed via the front panel. Reception of this code by the switcher is not valid.

NOTE 11 - For machines where the video and/or audio gain is programmable.

NOTE 12 - Under normal conditions, the machine's present status is saved each time a change is made. The "power-down" save (auto-save) may be disabled using this code. Note that whenever the machine is turned on, the auto-save function is set.

NOTE 13 - This is a request to identify the switcher/s in the system. If the OUTPUT is set as 0, and the INPUT is set as 1, 2, 5 or 7, the machine sends its name. The reply is the decimal value of the INPUT and OUTPUT. For example, for a 2216, the reply to the request to send the audio machine name would be (HEX codes):

7D 96 90 81 (i.e. 128dec+ 22dec for 2nd byte, and 128dec+ 16dec for 3rd byte).

If the request for identification is sent with the INPUT set as 3 or 4, the appropriate machine sends its software version number. Again, the reply would be the decimal value of the INPUT and OUTPUT - the INPUT representing the number in front of the decimal point, and the OUTPUT representing the number after it. For example, for version 3.5, the reply to the request to send the version number would be (HEX codes):

7D 83 85 81 (i.e. 128dec+ 3dec for 2nd byte, 128dec+ 5dec for 3rd byte).

If the OUTPUT is set as 1, then the ASCII coding of the lettering following the machine's name is sent. For example, for the VS-7588YC, the reply to the request to send the first suffix would be (HEX codes):

7D D9 C3 81 (i.e. 128dec+ ASCII for "Y"; 128dec+ ASCII for "C").

NOTE 14 - The number of inputs and outputs refers to the specific machine, which is being addressed, not to the system. For example, if six 16X16 matrices are configured to make a 48X32 system (48 inputs, 32 outputs), the reply to the HEX code

3E 82 81 82 (i.e. request the number of outputs)

would be HEX codes

7E 82 90 82

i.e. 16 outputs

NOTE 15 - When the OVR bit (4th byte) is set, then the "video" commands have universal meaning. For example, instruction 1 (SWITCH VIDEO) causes all units (including audio, data, etc.) to switch. Similarly, if a machine is in "FOLLOW" mode, it performs any "video" instruction.

NOTE 16 - The reply to the "REQUEST WHETHER PANEL IS LOCKED" is as in NOTE 4 above, except that here the OUTPUT is assigned with the value 0 if the panel is unlocked, or 1 if it is locked.

NOTE 19 - When data (i.e. the INPUT and/or OUTPUT bytes) of more than 7 bits is required, this instruction is sent before sending the instruction needing the additional bits. The data in this instruction then becomes the Most Significant Bits of that next instruction. For example, to set the audio gain (instruction 22) of output 3 to 681dec (2A9hex), you would first send HEX codes

3F 80 85 81

and then send HEX codes

16 83 A9 81

To set the audio gain of output 6 to 10013dec (271Dhex), first send HEX codes

3F 80 CE 81

followed by HEX codes

16 86 9D 81

NOTE 21 - Instruction 59 and instruction 60 load data for sending to the crosspoint switcher (or for storing in a SETUP), i.e. the data is "lined-up" to be executed later. Instruction 58 executes the loaded data.

NOTE 22 - If the INPUT byte is set as 127dec, then the data stored in a SETUP is loaded. The SETUP # is in the OUTPUT byte.

NOTE 23 - Further information needed in instructions 21, 22, 25 and 26, is sent using instruction 42 - which is sent prior to the instruction. For example, to request the audio gain value of right input # 9, send hex codes

2A 84 80 81

and then send HEX codes

19 89 81 81

LIMITED WARRANTY

The warranty obligations of Kramer Electronics for this product are limited to the terms set forth below:

What is Covered

This limited warranty covers defects in materials and workmanship in this product.

What is Not Covered

This limited warranty does not cover any damage, deterioration or malfunction resulting from any alteration, modification, improper or unreasonable use or maintenance, misuse, abuse, accident, neglect, exposure to excess moisture, fire, improper packing and shipping (such claims must be presented to the carrier), lightning, power surges, or other acts of nature. This limited warranty does not cover any damage, deterioration or malfunction resulting from the installation or removal of this product from any installation, any unauthorized tampering with this product, any repairs attempted by anyone unauthorized by Kramer Electronics to make such repairs, or any other cause which does not relate directly to a defect in materials and/or workmanship of this product. This limited warranty does not cover cartons, equipment enclosures, cables or accessories used in conjunction with this product.

Without limiting any other exclusion herein, Kramer Electronics does not warrant that the product covered hereby, including, without limitation, the technology and/or integrated circuit(s) included in the product, will not become obsolete or that such items are or will remain compatible with any other product or technology with which the product may be used.

How Long Does this Coverage Last

Seven years as of this printing; please check our Web site for the most current and accurate warranty information.

Who is Covered

Only the original purchaser of this product is covered under this limited warranty. This limited warranty is not transferable to subsequent purchasers or owners of this product.

What Kramer Electronics will do

Kramer Electronics will, at its sole option, provide one of the following three remedies to whatever extent it shall deem necessary to satisfy a proper claim under this limited warranty:

1. Elect to repair or facilitate the repair of any defective parts within a reasonable period of time, free of any charge for the necessary parts and labor to complete the repair and restore this product to its proper operating condition. Kramer Electronics will also pay the shipping costs necessary to return this product once the repair is complete.
2. Replace this product with a direct replacement or with a similar product deemed by Kramer Electronics to perform substantially the same function as the original product.
3. Issue a refund of the original purchase price less depreciation to be determined based on the age of the product at the time remedy is sought under this limited warranty.

What Kramer Electronics will not do Under This Limited Warranty

If this product is returned to Kramer Electronics or the authorized dealer from which it was purchased or any other party authorized to repair Kramer Electronics products, this product must be insured during shipment, with the insurance and shipping charges prepaid by you. If this product is returned uninsured, you assume all risks of loss or damage during shipment. Kramer Electronics will not be responsible for any costs related to the removal or re-installation of this product from or into any installation. Kramer Electronics will not be responsible for any costs related to any setting up this product, any adjustment of user controls or any programming required for a specific installation of this product.

How to Obtain a Remedy under this Limited Warranty

To obtain a remedy under this limited warranty, you must contact either the authorized Kramer Electronics reseller from whom you purchased this product or the Kramer Electronics office nearest you. For a list of authorized Kramer Electronics resellers and/or Kramer Electronics authorized service providers, please visit our web site at www.kramerelectronics.com or contact the Kramer Electronics office nearest you.

In order to pursue any remedy under this limited warranty, you must possess an original, dated receipt as proof of purchase from an authorized Kramer Electronics reseller. If this product is returned under this limited warranty, a return authorization number, obtained from Kramer Electronics, will be required. You may also be directed to an authorized reseller or a person authorized by Kramer Electronics to repair the product.

If it is decided that this product should be returned directly to Kramer Electronics, this product should be properly packed, preferably in the original carton, for shipping. Cartons not bearing a return authorization number will be refused.

Limitation on Liability

THE MAXIMUM LIABILITY OF KRAMER ELECTRONICS UNDER THIS LIMITED WARRANTY SHALL NOT EXCEED THE ACTUAL PURCHASE PRICE PAID FOR THE PRODUCT. TO THE MAXIMUM EXTENT PERMITTED BY LAW, KRAMER ELECTRONICS IS NOT RESPONSIBLE FOR DIRECT, SPECIAL, INCIDENTAL OR CONSEQUENTIAL DAMAGES RESULTING FROM ANY BREACH OF WARRANTY OR CONDITION, OR UNDER ANY OTHER LEGAL THEORY. Some countries, districts or states do not allow the exclusion or limitation of relief, special, incidental, consequential or indirect damages, or the limitation of liability to specified amounts, so the above limitations or exclusions may not apply to you.

Exclusive Remedy

TO THE MAXIMUM EXTENT PERMITTED BY LAW, THIS LIMITED WARRANTY AND THE REMEDIES SET FORTH ABOVE ARE EXCLUSIVE AND IN LIEU OF ALL OTHER WARRANTIES, REMEDIES AND CONDITIONS, WHETHER ORAL OR WRITTEN, EXPRESS OR IMPLIED. TO THE MAXIMUM EXTENT PERMITTED BY LAW, KRAMER ELECTRONICS SPECIFICALLY DISCLAIMS ANY AND ALL IMPLIED WARRANTIES, INCLUDING, WITHOUT LIMITATION, WARRANTIES OF MERCHANTABILITY AND FITNESS FOR A PARTICULAR PURPOSE. IF KRAMER ELECTRONICS CANNOT LAWFULLY DISCLAIM OR EXCLUDE IMPLIED WARRANTIES UNDER APPLICABLE LAW, THEN ALL IMPLIED WARRANTIES COVERING THIS PRODUCT, INCLUDING WARRANTIES OF MERCHANTABILITY AND FITNESS FOR A PARTICULAR PURPOSE, SHALL APPLY TO THIS PRODUCT AS PROVIDED UNDER APPLICABLE LAW.

IF ANY PRODUCT TO WHICH THIS LIMITED WARRANTY APPLIES IS A "CONSUMER PRODUCT" UNDER THE MAGNUSON-MOSS WARRANTY ACT (15 U.S.C.A. §2301, ET SEQ.) OR OTHER APPLICABLE LAW, THE FOREGOING DISCLAIMER OF IMPLIED WARRANTIES SHALL NOT APPLY TO YOU, AND ALL IMPLIED WARRANTIES ON THIS PRODUCT, INCLUDING WARRANTIES OF MERCHANTABILITY AND FITNESS FOR THE PARTICULAR PURPOSE, SHALL APPLY AS PROVIDED UNDER APPLICABLE LAW.

Other Conditions

This limited warranty gives you specific legal rights, and you may have other rights which vary from country to country or state to state.

This limited warranty is void if (i) the label bearing the serial number of this product has been removed or defaced, (ii) the product is not distributed by Kramer Electronics or (iii) this product is not purchased from an authorized Kramer Electronics reseller. If you are unsure whether a reseller is an authorized Kramer Electronics reseller, please visit our Web site at www.kramerelectronics.com or contact a Kramer Electronics office from the list at the end of this document.

Your rights under this limited warranty are not diminished if you do not complete and return the product registration form or complete and submit the online product registration form. Kramer Electronics thanks you for purchasing a Kramer Electronics product. We hope it will give you years of satisfaction.



For the latest information on our products and a list of Kramer distributors, visit our Web site where updates to this user manual may be found.

We welcome your questions, comments, and feedback.

Web site: www.kramerelectronics.com

E-mail: info@kramerel.com

CE



SAFETY WARNING

Disconnect the unit from the power supply before opening and servicing



P/N: 2900-001608



Rev: 5