



KRAMER ELECTRONICS LTD.

USER MANUAL

MODEL:

WP-121

XGA/Unbalanced Stereo Audio
Line Transmitter

P/N: 2900-000622 Rev 5

Contents

1	Introduction	1
2	Getting Started	2
2.1	Achieving the Best Performance	2
3	Overview	3
3.1	About the Power Connect™ Feature	3
3.2	Shielded Twisted Pair (STP)/Unshielded Twisted Pair (UTP)	4
3.3	Defining EDID	4
4	Defining the WP-121	5
5	Installing and Connecting the WP-121	7
5.1	Installing the WP-121	7
5.2	Connecting the WP-121	7
5.3	Grounding the Wall Plate	8
5.1	Wiring the TP LINE IN / LINE OUT RJ-45 Connectors	9
5.2	Wiring the 9-Pin Terminal Block Line Output Connector	10
6	Capturing the EDID	11
7	Capturing the EDID from a Display Device	12
8	Technical Specifications	14

Figures

Figure 1:	WP-121 US Version (69mm)	5
Figure 2:	WP-121 Front Panel (80/86mm)	6
Figure 3:	WP-121 Rear Panel (80/86mm)	6
Figure 4:	Installing and Connecting the WP-121	8
Figure 5:	Ground Connection	8
Figure 6:	TP PINOUT	9
Figure 7:	Terminal Block Pinouts	10
Figure 8:	WP-121 PCB Assembly Front View with Face Plate Removed	11

1 Introduction

Welcome to Kramer Electronics! Since 1981, Kramer Electronics has been providing a world of unique, creative, and affordable solutions to the vast range of problems that confront video, audio, presentation, and broadcasting professionals on a daily basis. In recent years, we have redesigned and upgraded most of our line, making the best even better!

Our 1,000-plus different models now appear in 11 groups that are clearly defined by function: GROUP 1: Distribution Amplifiers; GROUP 2: Switchers and Routers; GROUP 3: Control Systems; GROUP 4: Format/Standards Converters; GROUP 5: Range Extenders and Repeaters; GROUP 6: Specialty AV Products; GROUP 7: Scan Converters and Scalers; GROUP 8: Cables and Connectors; GROUP 9: Room Connectivity; GROUP 10: Accessories and Rack Adapters and GROUP 11: Sierra Video Products.

Congratulations on purchasing your Kramer **WP-121 XGA/Unbalanced Stereo Audio Line Transmitter**, which is ideal for the following typical applications:

- Presentation and multimedia applications
- Long range graphics distribution for schools, hospitals, security and stores

The package includes the following items:

- **WP-121 XGA/Unbalanced Stereo Audio Line Transmitter**
- A 12V DC power supply
- This user manual

Download up-to-date Kramer user manuals from our Web site at <http://www.kramerelectronics.com>



All references to **WP-121** in this manual refer to the US version (69mm) as well as to the **WP-121** 80mm and **WP-121** 86mm European versions.

2 Getting Started

We recommend that you:

- Unpack the equipment carefully and save the original box and packaging materials for possible future shipment
- Review the contents of this user manual
- Use Kramer high performance high resolution cables



Go to <http://www.kramerelectronics.com> to check for up-to-date user manuals, application programs, and to check if firmware upgrades are available (where appropriate).



Caution: No operator serviceable parts inside the unit

Warning: Use only the Kramer Electronics input power wall adapter that is provided with the unit

Warning: Disconnect the power and unplug the unit from the wall before installing

2.1 Achieving the Best Performance

To achieve the best performance:

- Use only good quality connection cables to avoid interference, deterioration in signal quality due to poor matching, and elevated noise levels (often associated with low quality cables)
- Do not secure the cables in tight bundles or roll the slack into tight coils
- Avoid interference from neighboring electrical appliances that may adversely influence signal quality
- Position your Kramer **WP-121** away from moisture, excessive sunlight and dust

3 Overview

The Kramer **WP-121** wall plate is a line transmitter that accepts a UXGA video and an unbalanced stereo audio signal, encodes them to a twisted pair (TP) signal and transmits the TP signal to a compatible TP receiver.

For example, the Kramer TP-122/N or TP-122-od.

The **WP-121 XGA/Unbalanced Stereo Audio Line Transmitter** features:

- HDTV compatibility up to 1080p
- The option to use either a 9-pin terminal block or RJ-45 output TP connector
Only one can be connected at a time to a TP receiver. Connecting both simultaneously results in neither operating
- Kramer Power Connect™
- EDID Capture copies and stores the EDID from a display device
- 12V DC power supply

3.1 About the Power Connect™ Feature

The Power Connect feature applies as long as the cable can carry power. This feature is available when using STP cable and the distance does not exceed 50m (164ft) on standard CAT 5 cable. For longer distances, heavy gauge cable should be used (CAT 5 cable is still suitable for the video/audio transmission, but not for feeding the power at these distances). For units which are connected via RJ-45 connectors, make sure that the shield of the STP cable is connected to the metal casing of the connectors on both ends of the cable. For units which are connected via terminal block connectors, the shield of the STP cable must be connected to a ground terminal on the units at both ends (use the ground terminal of the power supply connection if necessary).

For a CAT 5 cable exceeding a distance of 50m, separate power supplies should be connected to the transmitter and to the receiver simultaneously.

3.2 Shielded Twisted Pair (STP)/Unshielded Twisted Pair (UTP)

We recommend that you use Shielded Twisted Pair (STP) cable, and stress that the compliance to electromagnetic interference was tested using STP cable.

There are different levels of STP cable available, and we advise you to use the best quality STP cable that you can afford. Our non-skew-free cable, Kramer **BC-STP** is intended for analog signals where skewing is not an issue.

In cases where there is skewing, our Unshielded Twisted Pair (UTP) skew-free cable, Kramer **BC-XTP**, may be advantageous, and UTP cable might also be preferable for long range applications. In any event when using UTP cable, it is advisable to ensure that the cable is installed far away from electric cables, motors and so on, which are prone to create electrical interference.

3.3 Defining EDID

The Extended Display Identification Data (EDID) is a data-structure provided by a display, to describe its capabilities to a graphics card (that is connected to the display's source). The EDID enables the **WP-121** to "know" what kind of monitor is connected to the output. The EDID includes the manufacturer's name, the product type, the timing data supported by the display, the display size, luminance data and (for digital displays only) the pixel mapping data.

EDID is defined by a standard published by the Video Electronics Standards Association (VESA).

The **WP-121** is supplied with a default EDID but it can also store and recall EDID data in non-volatile memory, allowing convenient and reliable connection to the source.

4 Defining the WP-121

Figure 1 defines the WP-121.

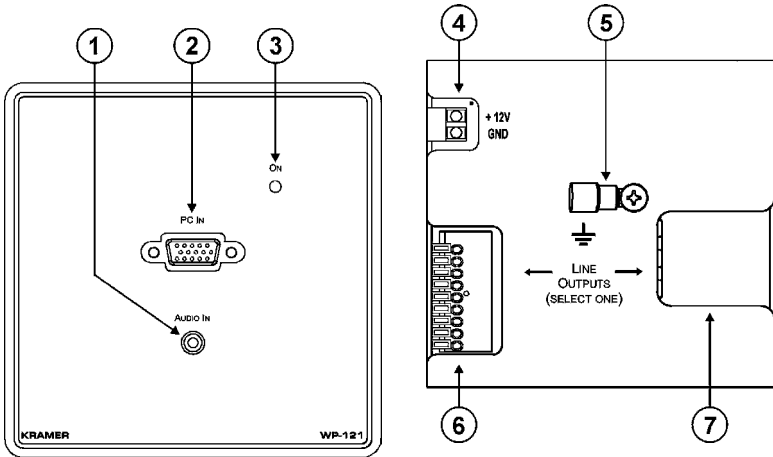

Figure 1: WP-121 US Version (69mm)

#	Feature	Function
1	AUDIO IN 3.5mm Mini Jack	Connect to an unbalanced stereo audio source
2	PC IN XGA 15-Pin HD (F) Connector	Connect to the XGA source
3	ON LED	Lights red when receiving power, lights green when receiving a signal from a video source
4	+12V PIN	Power — Connect to the positive (+) of the power adapter
	GND PIN	Removable Terminal Block Connect to the negative (-) of the power adapter
5		Ground connection. Ring-tongue terminal and grounding screw
6	LINE OUTPUTS	9-Pin TP terminal block
7		RJ-45 TP connector

Figure 2 and Figure 3 define the **WP-121** front and rear panels, respectively, for the European 80mm and 86mm versions.

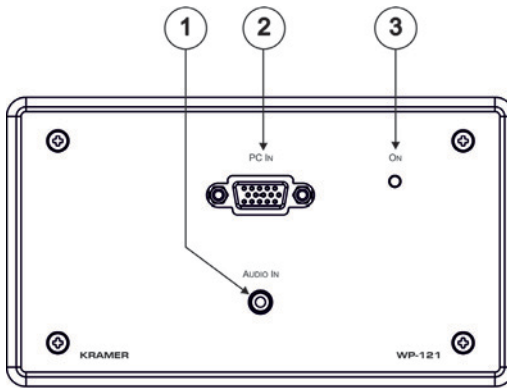

Figure 2: WP-121 Front Panel (80/86mm)

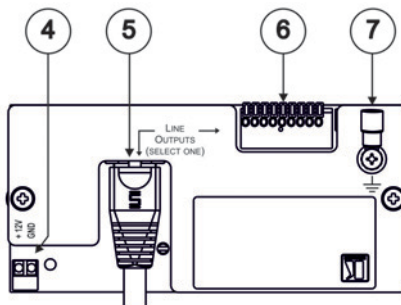



Figure 3: WP-121 Rear Panel (80/86mm)

#	Feature	Function
1	AUDIO IN 3.5mm Mini Jack	Connect to an unbalanced stereo audio source
2	PC IN XGA 15-Pin HD (F) Connector	Connect to the XGA source
3	ON LED	Lights red when receiving power, lights green when receiving a signal from a video source
4	+12V PIN	Power — Connect to the positive (+) of the power adapter
	GND PIN	Removable Terminal Block Connect to the negative (-) of the power adapter
5	LINE OUTPUTS	RJ-45 TP connector
6		9-pin TP terminal block
7		Ground connection. Ring-tongue terminal and grounding screw

5 Installing and Connecting the WP-121

This section explains how to install and connect the **WP-121**.

5.1 Installing the WP-121

To install the **WP-121** as illustrated in the example in [Figure 4](#):

1. Connect either the:
 - Terminal block line output of the **WP-121** to the pre-installed STP wiring in the wall box opening that connects to the TP receiver
—or—
 - RJ-45 line output of the **WP-121** to the pre-installed STP wiring in the wall box opening that connects to the TP receiver
2. Recommended—ground the wall plate (see [Section 5.3](#)).
3. Connect the 12V DC power supply to the power terminal block taking care that the polarity is correct.
Connect the wire labeled “+” to the +12V pin, and the wire labeled “-” to the GND pin.
4. Insert the **WP-121** into the wall box opening and secure the **WP-121** front panel using the screws.

5.2 Connecting the WP-121

To connect the **WP-121** as illustrated in the example in [Figure 4](#):

Note: Do **not** connect both the RJ-45 and terminal block connectors to receivers. If you do so, neither will work.

1. Connect the UXGA source to the PC IN connector (for example, a computer graphics source).
2. Connect the unbalanced stereo source to the AUDIO IN connector (for example, the audio signal from the computer graphics source).

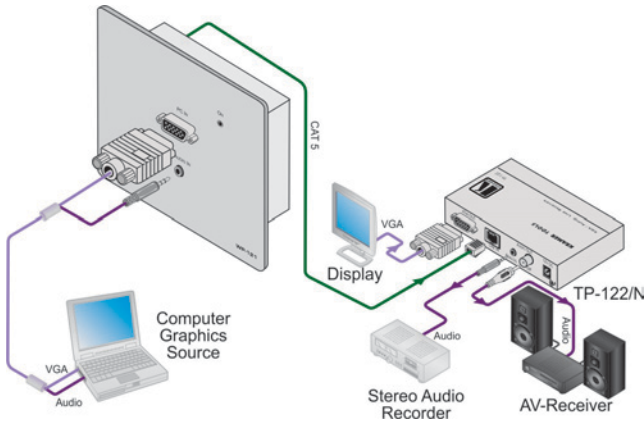

Figure 4: Installing and Connecting the WP-121

5.3 Grounding the Wall Plate

Grounding the **WP-121** is recommended. The grounding wire is connected to the rear of the chassis of the unit. The grounding screw is used to earth the unit to the ground of the building. This helps prevent static electricity from interfering with product performance.

To connect the grounding to the **WP-121** as shown in [Figure 5](#):

1. Crimp the ring-tongue terminal to the building grounding point wire.
(We recommend that you use a green-yellow #18 AWG wire (0.82mm²) crimped with a proper hand-tool).
2. Insert the M3x6 screw through the toothed lock washers and the ring-tongue terminal in the order shown above.
3. Insert the M3x6 screw (with the two toothed lock washers and ring-tongue terminal in place) into the grounding screw hole on the rear of the **WP-121** and tighten the screw.

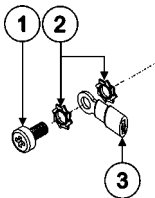

#	Item
1	M3x6 Screw
2	M3 Toothed lock washers
3	M3 Ring tongue terminal

Figure 5: Ground Connection

5.1 Wiring the TP LINE IN / LINE OUT RJ-45 Connectors

This section defines the TP pinout, using a **straight** pin-to-pin cable with RJ-45 connectors.



Note, that the cable Ground shielding must be connected / soldered to the connector shield.

EIA /TIA 568B	
PIN	Wire Color
1	Orange / White
2	Orange
3	Green / White
4	Blue
5	Blue / White
6	Green
7	Brown / White
8	Brown

Figure 6: TP PINOUT

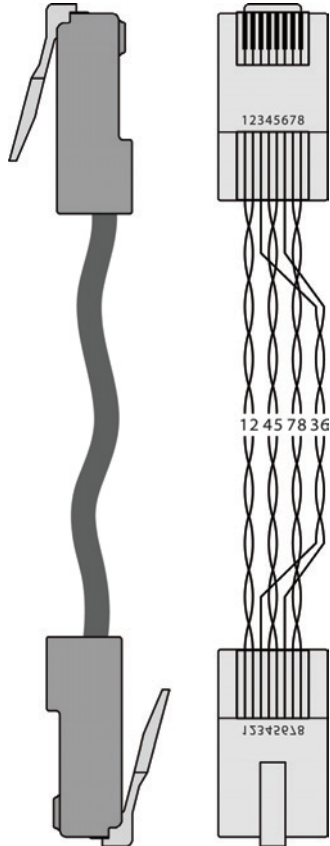

5.2 Wiring the 9-Pin Terminal Block Line Output Connector

The 9-pin terminal block is a plug-in connector for attaching the STP cable. Follow the colors of the color-coded sticker on these terminals for proper connection of the cable.

[Figure 7](#) defines the pinouts for the terminal block.

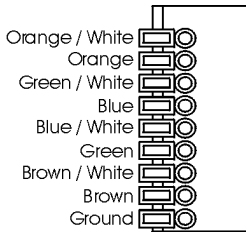

Figure 7: Terminal Block Pinouts

Notes:

- Use the connector clips only when removing wires, not when inserting them
- Each wire should protrude 9mm (0.35") from the plastic insulation so that it can be easily connected. To prevent the wires crossing, be sure that each wire is fully inserted

6 Capturing the EDID

The EDID can either be captured automatically by the **WP-121** transmitter, or you can set it manually with one of the preconfigured values (see [Section 7](#)).

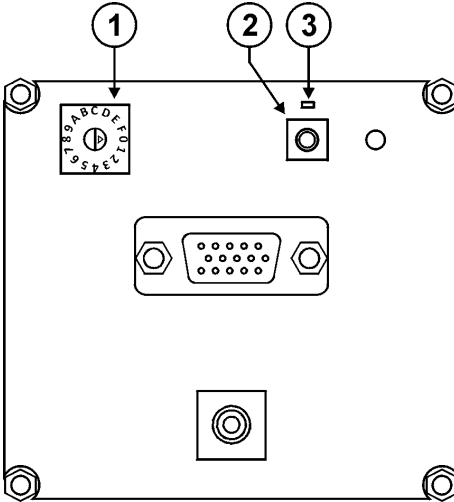

Figure 8: WP-121 PCB Assembly Front View with Face Plate Removed

#	Feature	Function
1	16 Position Rotary Switch	Turn to select the EDID resolution and refresh rate (see Section 7)
2	EDID Capture Button	Press to capture the EDID
3	EDID Status LED	Flashes slowly when capturing a valid display EDID, Lights solid when EDID has been successfully captured, Flashes rapidly when setting a preconfigured EDID

7 Capturing the EDID from a Display Device

To capture the EDID from a display device:

1. Using a Philips screwdriver, remove the four screws holding the faceplate to the PCB assembly.
2. Using a short cable (for example, Kramer model number C-MGM/MGM-1), connect the PC IN input 15-pin HD connector on the **WP-121** to the XGA connector of the display and turn the display on.
3. Ensure that the rotary switch (see [Figure 8](#)) is in position 0. If it is not, use a small screwdriver to turn it to 0.
4. Connect the 12V DC power adapter to the power terminal block (see [Figure 4](#)) on the **WP-121** and connect the adapter to the mains electricity.
5. Press the EDID capture button (see [Figure 8](#)).
The EDID status LED flashes slowly several times. The new EDID is captured when the LED stops flashing and lights solid.
6. Unplug the power adapter from the mains and disconnect it from the **WP-121**.
7. Replace the faceplate and secure the four screws removed in Step 1.

To set a preconfigured EDID:

1. Using a Philips screwdriver, remove the four screws holding the front panel to the rear PCB assembly.
2. Using a small screwdriver, turn the rotary switch (see [Figure 8](#)) to the required position as defined in the table below.
3. Connect the 12V DC power adapter to the power terminal block (see [Figure 4](#)) on the **WP-121** and connect the adapter to the mains electricity.

4. Press the EDID CAPTURE button (see [Figure 8](#)).
The EDID status LED flashes rapidly several times. The new EDID is captured when the LED stops flashing and lights solid.
5. Unplug the power adapter from the mains and disconnect it from the **WP-121**.
6. Replace the faceplate and secure the four screws removed in Step 1.

Rotary Switch Position	Resolution	Refresh Rate
0 (Default)	1024x768	60Hz
1	800x600	60Hz
2	1024x768	60Hz
3	1152x864	75Hz
4	1280x720	60Hz
5	1280x800	60Hz
6	1024x1024	60Hz
7	1360x768	60Hz

Rotary Switch Position	Resolution	Refresh Rate
8	1440x900	60Hz
9	1440x1050	60Hz
A	1600x1200	60Hz
B	1680x1050	60Hz
C	1920x1080	60Hz
D	1920x1200	60Hz
E	For future use	
F	For future use	

8 Technical Specifications

INPUTS:	1 UXGA on a 15-pin HD (F) connector 1 Unbalanced stereo audio on a 3.5mm mini jack 1 Power 12V DC on 2-pin removable terminal block	
OUTPUTS:	1 STP on a 9-pin terminal block with springs 1 STP on an RJ-45 connector	
MAX. OUTPUT LEVEL:	Video: 2Vpp	Audio: 2.8Vpp
RESOLUTION:	Up to UXGA, 1080p	
AUDIO BANDWIDTH:	18KHz	
DIFF. GAIN:	1.8%	
DIFF. PHASE:	0.3 Deg	
K-FACTOR:	<0.05%	
S/N RATIO:	Video: 60dB @ 5MHz	Audio: 71dB @ 1KHz
COUPLING:	Video: AC	Audio: AC
AUDIO THD + NOISE:	0.07%	
AUDIO 2 nd HARMONIC:	0.001%	
POWER SOURCE:	12V DC 340mA (feeding a TP-112 or TP-122-od receiver)	
OPERATING TEMPERATURE:	0° to +55°C (32° to 131°F)	
STORAGE TEMPERATURE:	-45° to +72°C (-49° to 162°F)	
HUMIDITY:	10% to 90%, RHL non-condensing	
DIMENSIONS:	2 gang for the USA: 11.4cm x 3.5 cm x 11.4cm (4.49" x 1.4" x 4.49", W, D, H) 2 gang for Europe: 15.2cm x 3.5cm x 8.0/8.6cm (5.98" x 1.4" x 3.15/3.39", W, D, H)	
WEIGHT:	0.14kg (0.31lbs) approx.	
ACCESSORIES:	Power adapter	
Specifications are subject to change without notice at http://www.kramerelectronics.com		

LIMITED WARRANTY

The warranty obligations of Kramer Electronics for this product are limited to the terms set forth below:

What is Covered

This limited warranty covers defects in materials and workmanship in this product.

What is Not Covered

This limited warranty does not cover any damage, deterioration or malfunction resulting from any alteration, modification, improper or unreasonable use or maintenance, misuse, abuse, accident, neglect, exposure to excess moisture, fire, improper packing and shipping (such claims must be presented to the carrier), lightning, power surges, or other acts of nature. This limited warranty does not cover any damage, deterioration or malfunction resulting from the installation or removal of this product from any installation, any unauthorized tampering with this product, any repairs attempted by anyone unauthorized by Kramer Electronics to make such repairs, or any other cause which does not relate directly to a defect in materials and/or workmanship of this product. This limited warranty does not cover cartons, equipment enclosures, cables or accessories used in conjunction with this product.

Without limiting any other exclusion herein, Kramer Electronics does not warrant that the product covered hereby, including, without limitation, the technology and/or integrated circuit(s) included in the product, will not become obsolete or that such items are or will remain compatible with any other product or technology with which the product may be used.

How Long Does this Coverage Last

Seven years as of this printing; please check our Web site for the most current and accurate warranty information.

Who is Covered

Only the original purchaser of this product is covered under this limited warranty. This limited warranty is not transferable to subsequent purchasers or owners of this product.

What Kramer Electronics will do

Kramer Electronics will, at its sole option, provide one of the following three remedies to whatever extent it shall deem necessary to satisfy a proper claim under this limited warranty:

1. Elect to repair or facilitate the repair of any defective parts within a reasonable period of time, free of any charge for the necessary parts and labor to complete the repair and restore this product to its proper operating condition. Kramer Electronics will also pay the shipping costs necessary to return this product once the repair is complete.
2. Replace this product with a direct replacement or with a similar product deemed by Kramer Electronics to perform substantially the same function as the original product.
3. Issue a refund of the original purchase price less depreciation to be determined based on the age of the product at the time remedy is sought under this limited warranty.

What Kramer Electronics will not do Under This Limited Warranty

If this product is returned to Kramer Electronics or the authorized dealer from which it was purchased or any other party authorized to repair Kramer Electronics products, this product must be insured during shipment, with the insurance and shipping charges prepaid by you. If this product is returned uninsured, you assume all risks of loss or damage during shipment. Kramer Electronics will not be responsible for any costs related to the removal or re-installation of this product from or into any installation. Kramer Electronics will not be responsible for any costs related to any setting up this product, any adjustment of user controls or any programming required for a specific installation of this product.

How to Obtain a Remedy under this Limited Warranty

To obtain a remedy under this limited warranty, you must contact either the authorized Kramer Electronics reseller from whom you purchased this product or the Kramer Electronics office nearest you. For a list of authorized Kramer Electronics resellers and/or Kramer Electronics authorized service providers, please visit our web site at www.kramerelectronics.com or contact the Kramer Electronics office nearest you.

In order to pursue any remedy under this limited warranty, you must possess an original, dated receipt as proof of purchase from an authorized Kramer Electronics reseller. If this product is returned under this limited warranty, a return authorization number, obtained from Kramer Electronics, will be required. You may also be directed to an authorized reseller or a person authorized by Kramer Electronics to repair the product.

If it is decided that this product should be returned directly to Kramer Electronics, this product should be properly packed, preferably in the original carton, for shipping. Cartons not bearing a return authorization number will be refused.

Limitation on Liability

THE MAXIMUM LIABILITY OF KRAMER ELECTRONICS UNDER THIS LIMITED WARRANTY SHALL NOT EXCEED THE ACTUAL PURCHASE PRICE PAID FOR THE PRODUCT. TO THE MAXIMUM EXTENT PERMITTED BY LAW, KRAMER ELECTRONICS IS NOT RESPONSIBLE FOR DIRECT, SPECIAL, INCIDENTAL OR CONSEQUENTIAL DAMAGES RESULTING FROM ANY BREACH OF WARRANTY OR CONDITION, OR UNDER ANY OTHER LEGAL THEORY. Some countries, districts or states do not allow the exclusion or limitation of relief, special, incidental, consequential or indirect damages, or the limitation of liability to specified amounts, so the above limitations or exclusions may not apply to you.

Exclusive Remedy

TO THE MAXIMUM EXTENT PERMITTED BY LAW, THIS LIMITED WARRANTY AND THE REMEDIES SET FORTH ABOVE ARE EXCLUSIVE AND IN LIEU OF ALL OTHER WARRANTIES, REMEDIES AND CONDITIONS, WHETHER ORAL OR WRITTEN, EXPRESS OR IMPLIED. TO THE MAXIMUM EXTENT PERMITTED BY LAW, KRAMER ELECTRONICS SPECIFICALLY DISCLAIMS ANY AND ALL IMPLIED WARRANTIES, INCLUDING, WITHOUT LIMITATION, WARRANTIES OF MERCHANTABILITY AND FITNESS FOR A PARTICULAR PURPOSE. IF KRAMER ELECTRONICS CANNOT LAWFULLY DISCLAIM OR EXCLUDE IMPLIED WARRANTIES UNDER APPLICABLE LAW, THEN ALL IMPLIED WARRANTIES COVERING THIS PRODUCT, INCLUDING WARRANTIES OF MERCHANTABILITY AND FITNESS FOR A PARTICULAR PURPOSE, SHALL APPLY TO THIS PRODUCT AS PROVIDED UNDER APPLICABLE LAW.

IF ANY PRODUCT TO WHICH THIS LIMITED WARRANTY APPLIES IS A "CONSUMER PRODUCT" UNDER THE MAGNUSON-MOSS WARRANTY ACT (15 U.S.C.A. §2301, ET SEQ.) OR OTHER APPLICABLE LAW, THE FOREGOING DISCLAIMER OF IMPLIED WARRANTIES SHALL NOT APPLY TO YOU, AND ALL IMPLIED WARRANTIES ON THIS PRODUCT, INCLUDING WARRANTIES OF MERCHANTABILITY AND FITNESS FOR THE PARTICULAR PURPOSE, SHALL APPLY AS PROVIDED UNDER APPLICABLE LAW.

Other Conditions

This limited warranty gives you specific legal rights, and you may have other rights which vary from country to country or state to state.

This limited warranty is void if (i) the label bearing the serial number of this product has been removed or defaced, (ii) the product is not distributed by Kramer Electronics or (iii) this product is not purchased from an authorized Kramer Electronics reseller. If you are unsure whether a reseller is an authorized Kramer Electronics reseller, please visit our Web site at www.kramerelectronics.com or contact a Kramer Electronics office from the list at the end of this document.

Your rights under this limited warranty are not diminished if you do not complete and return the product registration form or complete and submit the online product registration form. Kramer Electronics thanks you for purchasing a Kramer Electronics product. We hope it will give you years of satisfaction.



For the latest information on our products and a list of Kramer distributors, visit our Web site where updates to this user manual may be found.

We welcome your questions, comments, and feedback.

Web site: www.kramerelectronics.com

E-mail: info@kramerel.com



SAFETY WARNING

Disconnect the unit from the power supply before opening and servicing



P/N: 2900-000622



Rev: 5